



D E S I G N E D T O L E A D

BWC Series

**High Efficiency Gas-Fired Hot Water
Direct Vent Condensing Boilers**

INSTALLATION INSTRUCTIONS

These instructions must be affixed on or adjacent to the boiler.

Models:

- **BWC070**
- **BWC090**
- **BWC120**
- **BWC151**



**Equipped with Honeywell
SOLA Control**

WARNING: Improper installation, adjustment, alteration, service or maintenance can cause property damage, injury, or loss of life. For assistance or additional information, consult a qualified installer, service agency or the gas supplier. This boiler requires a special venting system. Read these instructions carefully before installing.



Manufacturer of Hydronic Heating Products

P.O. Box 14818 3633 I. Street

Philadelphia, PA 19134

www.crownboiler.com

Table of Contents

I.	Product Description	2
II.	Specifications	2
III.	Before Installing	3
IV.	Locating The Boiler	3
V.	Mounting The Boiler	6
VI.	Air For Ventilation	9
VII.	Venting	11
	A. Vent System Design	11
	B. Removing An Existing Boiler From Common Chimney	21
	C. Assembly of Crown 60/100mm Concentric Venting	22
	D. Assembly of Crown 80/125mm Concentric Venting	26
	E. Assembly of Stainless Steel Venting	35
	F. Condensate Trap and Drain	40
VIII.	Gas Piping	42
IX.	System Piping	43
	A. General System Piping Precaution	43
	B. System Design	43
	C. Standard Piping Installation Requirements	50
	D. Piping For Special Situations	51
X.	Wiring	54
XI.	Start-up and Checkout	62
XII.	Operation	68
XIII.	Service and Maintenance	85
XIV.	Troubleshooting	87
XV.	Parts	91
	Appendix A: Optional Method for Retrofitting BWC Boilers into Existing Circulator Zone Systems	104
	Appendix B: Special Requirements For Side-Wall Vented Appliances In The Commonwealth of Massachusetts	105

I Product Description

The BWC070, BWC090, BWC120 and BWC151 are aluminum gas fired condensing boilers designed for use in forced hot water heating systems requiring supply water temperatures of 180°F or less. These boilers are designed for installation on a wall, however they may be floor mounted using an optional pedestal kit available from Crown. This boiler may be vented vertically or horizontally with combustion air supplied from outdoors. This boiler is not designed for use in gravity hot water systems or systems containing significant amounts of dissolved oxygen.

II Specifications

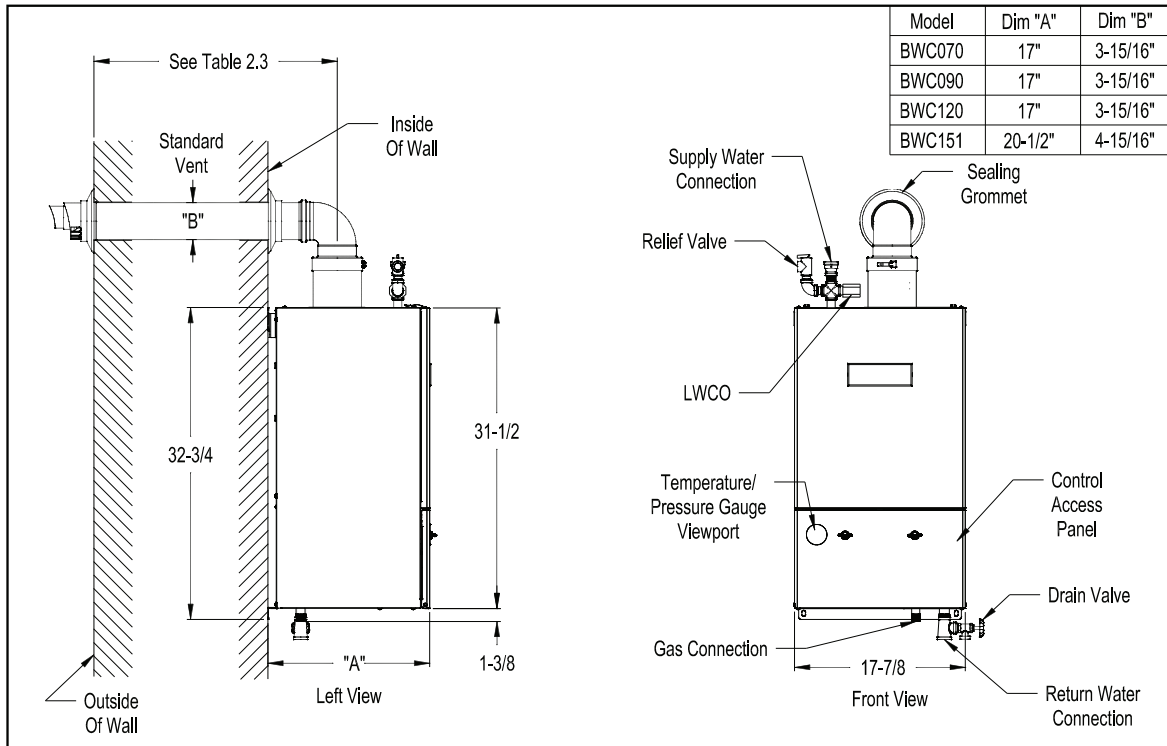

Figure 2.1: General Configuration

Table 2.2: Specifications

MODEL*	NO. OF SECTIONS	MAXIMUM INPUT (BTU/hr)	MINIMUM INPUT (BTU/hr)	D.O.E. HEATING CAPACITY (BTU/hr)	AHRI NET RATING (BTU/hr)	WATER VOLUME (Gal.)	SUPPLY & RETURN CONNECTION SIZE (NPT)	GAS CONNECTION SIZE (NPT)	APPROX. NET WEIGHT (lb)
BWC070	mono block	70,000	30,000	63,000	55,000	0.41	1"	1/2"	102
BWC090	mono block	90,000	30,000	80,000	70,000	0.41	1"	1/2"	102
BWC120	mono block	120,000	40,000	107,000	93,000	0.62	1"	1/2"	110
BWC151	mono block	150,000	50,000	135,000	119,000	1.13	1"	1/2"	133

* Add suffix "EN" for natural gas and "EL" for propane. Ratings are the same for both fuels.

Table 2.3: Maximum Vent Lengths

Using Concentric Vent System Supplied with the Boiler.....	25 in.
Using Optional 60/100mm Concentric Vent Components:	
BWC070.....	32 ft
BWC090.....	32 ft
BWC120.....	18 ft
Using Optional 80/125 Vertical Concentric Vent System.....	95ft
Using Optional 80/125 Horizontal Concentric Vent System.....	100ft
Using Approved 3" AL29-4C Horizontal Stainless Vent System and Optional Stainless Steel Vent Kit.....	100 ft

See Vent Section for additional venting options and requirements.

III Before Installing

- 1) Safe, reliable operation of this boiler depends upon installation by a professional heating contractor in strict accordance with this manual and the authority having jurisdiction.
 - In the absence of an authority having jurisdiction, installation must be in accordance with this manual and the National Fuel Gas Code, ANSI Z223.1. In Canada, installation must be in accordance with the B149.1 Installation Code.
 - Where required by the authority having jurisdiction, this installation must conform to the Standard for Controls and Safety Devices for Automatically Fired Boilers (ANSI/ASME CSD-1).
- 2) BWC boilers utilize aluminum heat exchangers constructed, tested, and stamped in accordance with ASME Boiler and Pressure Vessel Code Case 2382. Some jurisdictions which require ASME boiler construction do not recognize this Code Case and may not approve the installation of an aluminum boiler. Consult the authority having jurisdiction before installing this boiler.
- 3) Read Section VII to verify that the maximum combustion air and exhaust pipe lengths will not be exceeded in the planned installation. Also verify that the vent terminal can be located in accordance with Section VII.
- 4) Make sure that the boiler is correctly sized:
 - For heating systems employing convection radiation (baseboard or radiators), use an industry accepted sizing method such as the I=B=R Heat Loss Calculation Guide (Pub. #H21 or #H22) published by the Hydronics Institute in Berkely Heights, NJ.
 - For new radiant heating systems, refer to the radiant tubing manufacturer's boiler sizing guidelines.
 - For systems including a Crown Mega-Stor indirect water heater, size the boiler to have either the DOE Heating Capacity required for the Mega-Stor or the net rating required for the heating system, whichever results in the larger boiler.
 - For systems that incorporate other indirect water heaters, refer to the indirect water heater manufacturer's instructions for boiler output requirements.
- 5) Make sure that the boiler received is configured for the correct gas (natural or LP).
- 6) Make sure that the boiler is configured for use at the altitude at which it is to be installed.

NOTICE

This product must be installed by a licensed plumber or gas fitter when installed within the Commonwealth of Massachusetts. See Appendix A for additional important information about installing this product within the Commonwealth of Massachusetts.

IV Locating the Boiler

- 1) Observe the minimum clearances shown in Figure 4.1. These clearances apply to both combustible and non-combustible materials. Observe the minimum clearances to combustibles for vent pipe shown in Table 4.2.
- 2) Note the recommended service clearances in Figure 4.1. These service clearances are recommended, but may be reduced to the combustible clearances provided:
 - a. Access to the front of the boiler is provided through a door.
 - b. Access is provided to the condensate trap and transformer located underneath the boiler.
- 3) When the boiler is installed on the floor using the optional pedestal kit, the boiler may be installed on a non-carpeted combustible surface.
- 4) The relief valve must be installed in the factory specified location.

- 5) The boiler should be located so as to minimize the length of the vent system.
- 6) The combustion air piping must terminate where outdoor air is available for combustion and away from areas that will contaminate combustion air. Avoid areas near chemical products containing chlorine, chloride based salts, chloro/fluorocarbons, paint removers, cleaning solvents and detergents.

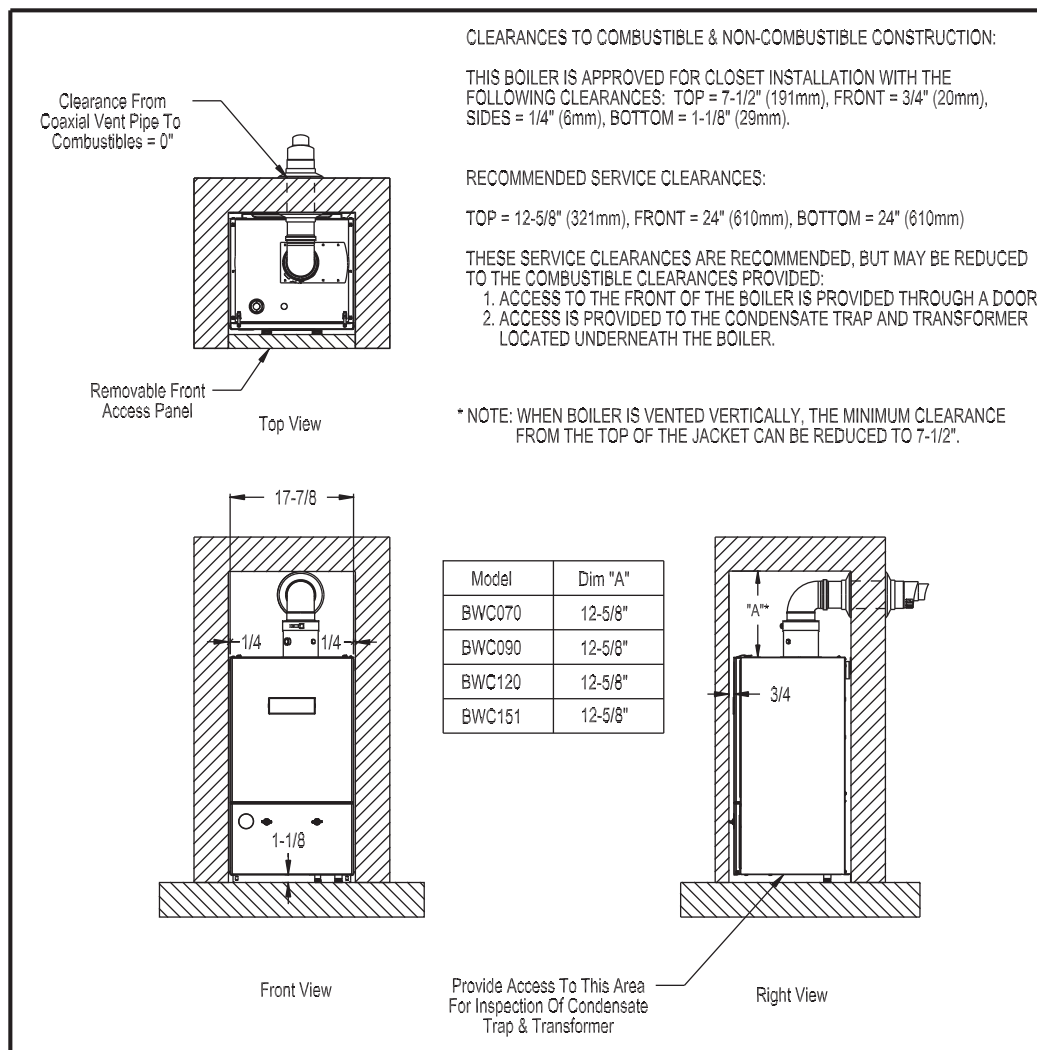

Figure 4.1: Clearances To Combustible Or Non-Combustible Material

Table 4.2: Clearances From Vent Piping To Combustible Construction

TYPE OF VENT PIPE	PIPE DIRECTION	ENCLOSURE	MINIMUM CLEARANCE TO COMBUSTIBLE MATERIAL
80/125 and 60/100mm CONCENTRIC VENTING	VERTICAL OR HORIZONTAL	ENCLOSED ON ALL FOUR SIDES	0" (0mm)
HEAT FAB SAF-T VENT PROTECH FASNSEAL Z-FLEX Z-VENT III METAL-FAB CORR/GUARD	VERTICAL OR HORIZONTAL	AT LEAST ONE SIDE OPEN, COMBUSTIBLE MATERIAL ON A MAXIMUM OF THREE SIDES	1" (26mm)
HEAT FAB SAF-T VENT PROTECH FASNSEAL Z-FLEX Z-VENT III METAL-FAB CORR/GUARD	HORIZONTAL OR VERTICAL WITH OFFSETS	ENCLOSED ON ALL FOUR SIDES	2-1/2" (64mm)
HEAT FAB SAF-T VENT PROTECH FASNSEAL Z-FLEX Z-VENT III METAL-FAB CORR/GUARD	VERTICAL WITH NO OFFSETS	ENCLOSED ON ALL FOUR SIDES	2-1/2" (64mm)

V Mounting The Boiler

A. Wall Mounting

CAUTION

This boiler weighs approximately 133 pounds:

- Two people are required to safely lift this boiler onto the wall mounting hook.
- Make sure that wall mounting hook is anchored to a structure capable of supporting the weight of the boiler and attached piping when filled with water. Jurisdictions in areas subject to earthquakes may have special requirements for supporting this boiler. These local requirements take precedence over the requirements shown below.

- 1) If the boiler is installed on a framed wall, minimum acceptable framing is 2 x 4 studs on 16" centers. The boiler mounting holes are on 16" centers for installation between two studs at the standard spacing. In cases where the boiler cannot be centered between the studs, or where the studs are spaced closer than 16" apart, the boiler may be anchored to $\frac{3}{4}$ " plywood or horizontal 2 x 4s anchored to the studs.
- 2) $\frac{5}{16}$ " x 2" lag screws and washers are provided for mounting this boiler. These lag screws are intended for mounting the boiler directly onto studs covered with $\frac{1}{2}$ " sheet rock. When the boiler is attached to other types of construction, such as masonry, use fasteners capable of supporting the weight of the boiler and attached piping in accordance with good construction practice and applicable local codes.
- 3) Make sure that the surface to which the boiler is mounted is plumb.
- 4) Before mounting the boiler, make sure that wall selected does not have any framing or other construction that will interfere with the vent pipe penetration.
- 5) Once a suitable location has been selected for the boiler, and any needed modifications have been made to the wall, use Figure 5.1 to locate holes "A" and "B". Make sure that the horizontal centerline of these holes is level. Holes "C" and "D" may also be drilled at this time or after the boiler is hung on the wall. If the $\frac{5}{16}$ " x 2" lag screws are used, drill $\frac{3}{16}$ " pilot holes.
- 6) Cut the opening/s in the wall for the vent system. The recommended hole diameter is 4-3/8" for 60/100mm coaxial pipe and 5-3/8" for 80/125mm pipe.
- 7) Attach the wall hanging hook using the $\frac{5}{16}$ " x 2" lag screws and washers, or other suitable anchors as appropriate (Figure 5.2). Make sure the hook is level.
- 8) Hang the boiler on the wall hook as shown in figure 5.2.
- 9) If not already done in Step (4) locate and drill holes "C" and "D" using the obround slots in the bottom mounting flange. Secure the bottom flange to the wall using the $\frac{5}{16}$ " x 2" lag screws, or other fasteners as appropriate (figure 5.2).
- 10) Verify that the front of the boiler is plumb. If it is not, install washers at holes "C" and "D" between the bottom mounting flange and the wall to adjust.
- 10) See Section VII (Venting) for instructions on attaching the vent system to the boiler.

B. Floor Mounting

This boiler may be mounted on the floor using an optional pedestal kit available from Crown. Follow the instructions provided with this kit to assemble the pedestal, and attach it to the boiler. When this pedestal is used, the boiler may be installed directly on a non-carpeted combustible floor.

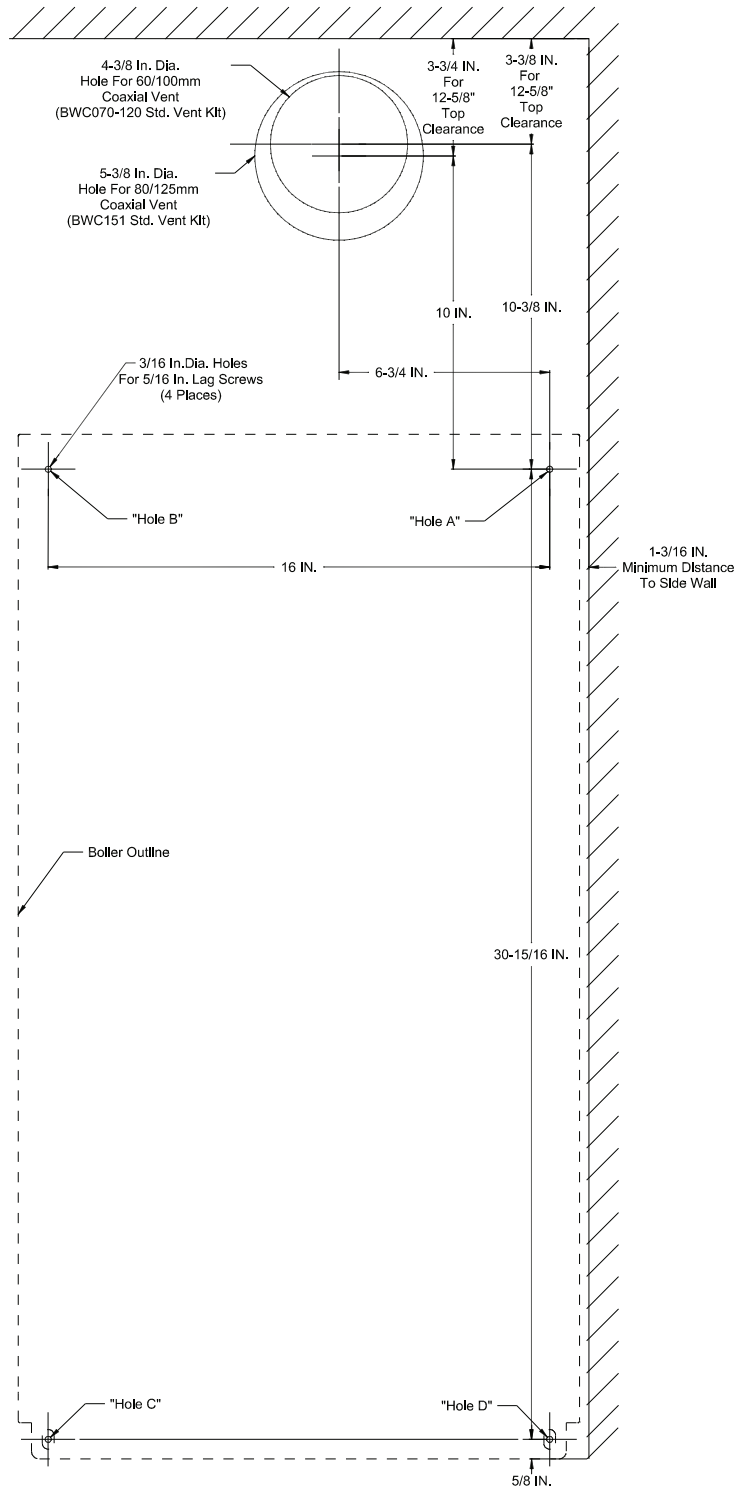

Figure 5.1 Wall Mounting Hole Locations

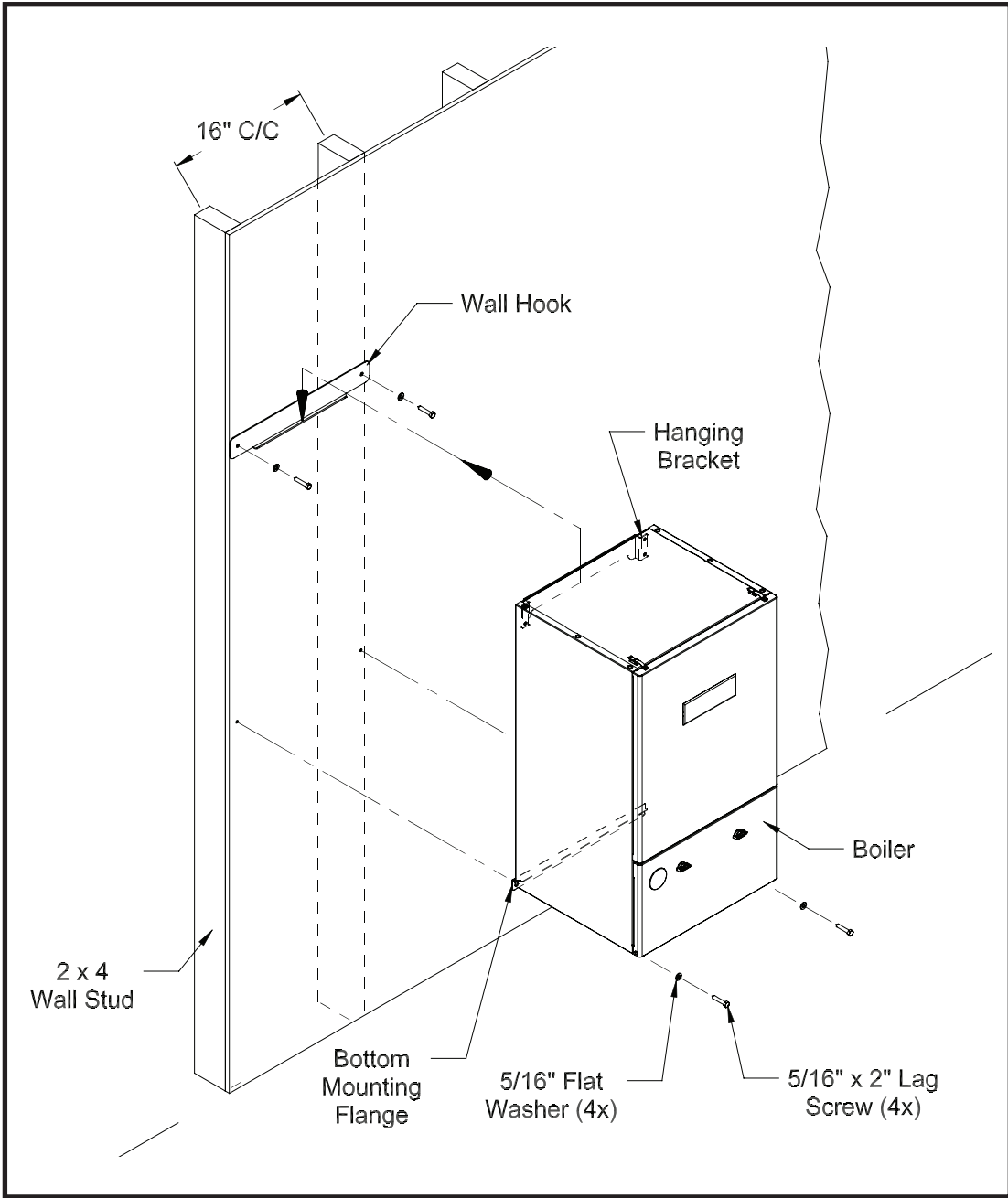

Figure 5.2 Boiler Mounting/Hardware

VI Air for Ventilation

WARNING

OUTDOOR COMBUSTION AIR MUST BE PIPED TO THE AIR INTAKE. NEVER PIPE COMBUSTION AIR FROM AREAS CONTAINING CONTAMINATES SUCH AS SWIMMING POOLS AND LAUNDRY ROOM EXHAUST VENTS. CONTAMINATED COMBUSTION AIR WILL DAMAGE THE BOILER AND MAY CAUSE PROPERTY DAMAGE, PERSONAL INJURY OR LOSS OF LIFE.

Air for combustion must always be obtained directly from outdoors, however sufficient air for ventilation must still be provided in the boiler room. Air for ventilation is required to keep various boiler components from overheating and is always obtained from indoors. To ensure an adequate ventilation air supply, perform the following steps:

Step 1: Determine whether the boiler is to be installed in a confined space - A confined space is defined by the National Fuel Gas Code as having a volume less than 50 cubic feet per 1000 BTU/hr input of all appliances installed in that space. To determine whether the boiler room is a confined space:

- 1) Total the input of all appliances in the boiler room in thousands of BTU/hr. Round the result to the next highest 1000 BTU/hr.
- 2) Find the volume of the room in cubic feet. The volume of the room in cubic feet is:

Length (ft) x width (ft) x ceiling height (ft)

In calculating the volume of the boiler room, consider the volume of adjoining spaces only if no doors are installed between them. If doors are installed between the boiler room and an adjoining space, do not consider the volume of the adjoining space, even if the door is normally left open.

- 3) Divide the volume of the boiler room by the input in thousands of BTU/hr. If the result is less than 50, the boiler room is a confined space.

Example:

A BWC120 and a water heater are to be installed in a room measuring 6ft – 3 in x 7ft with an 8 ft ceiling. The water heater has an input of 30000 BTU/hr:

Total input in thousands of BTU/hr = (120000 BTU/hr + 30000 BTU/hr) / 1000 = 150 MBTU/hr

Volume of room = 6.25 ft x 7 ft x 8 ft = 350 ft³

350/150 = 2.33. Since 2.33 is less than 50, the boiler room is a confined space.

Step 2a: If the boiler is to be placed in a confined space, provide two openings into the boiler room, one near the floor and one near the ceiling. The top edge of the upper opening must be within 12” of the ceiling and the bottom edge of the lower opening must be within 12” of the floor (Fig 6.1). The minimum opening dimension is 3 inches.

- If the BWC boiler is the only gas-burning appliance in the boiler room, these openings must each have a minimum free area of 100 square inches.
- If other gas-burning appliances are in the boiler room, size the openings in accordance with the appliance manufacturer’s instructions or the National Fuel Gas Code. Minimum opening free area is 100 square inches even if opening requirements for other appliances are less.

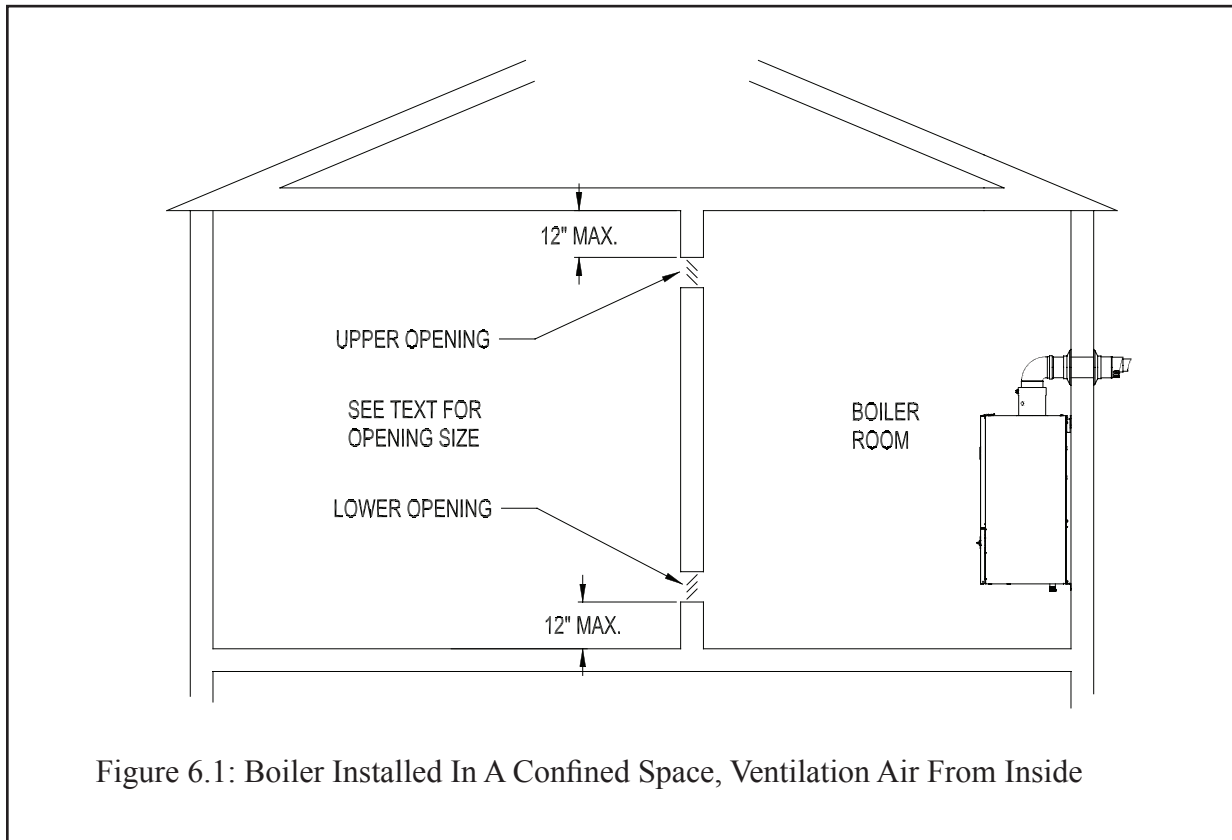

- If the total volume of both the boiler room and the room to which the openings connect is less than 50 cubic feet per 1000 BTU/hr of total appliance input, install a pair of identical openings into a third room. Connect additional rooms with openings until the total volume of all rooms is at least 50 cubic feet per 1000 BTU/hr of input.
- The “free area” of an opening takes into account the blocking effect of mesh, grills, and louvers. Where screens are used, they must be no finer than 1/4” (4 x 4) mesh.

Step 2b: If the boiler is to be placed in an unconfined space the natural infiltration into the boiler room will provide adequate air for ventilation without additional openings into boiler room.

VII Venting

WARNING

FAILURE TO VENT THIS BOILER IN ACCORDANCE WITH THESE INSTRUCTIONS COULD CAUSE FLUE GAS TO ENTER THE BUILDING RESULTING IN SEVERE PROPERTY DAMAGE, PERSONAL INJURY, OR DEATH:

- * Use only vent systems and materials explicitly permitted by Crown for use with this boiler. Do not use cellular core PVC, CPVC or Radel to vent this boiler.
- * Do not attempt to mix components from different approved vent systems.
- * Do not obtain combustion air from within the building.
- * Do not install a barometric damper or draft hood on this boiler.
- * Do not apply thermal insulation to plastic vent pipe.

CAUTION

Moisture and ice may form on the surfaces around the vent termination. To prevent deterioration, surfaces should be in good repair (sealed, painted, etc.).

A. Vent System Design

There are four basic ways to vent this boiler:

- **Horizontal (“Side Wall”) Concentric Venting** - Vent system exits the building through an outside wall. Concentric venting consists of a “pipe within a pipe”. Flue gas exits the building through the inner pipe and combustion air is drawn into the boiler through the space between the inner and outer pipe.
- **Horizontal (“Side Wall”) Twin Pipe Venting** - Vent system exits the building through an outside wall. Combustion air and flue gas are routed between the boiler and outdoors using separate pipes.
- **Vertical Concentric Venting** - Vent system exits the building through the roof. Concentric venting consists of a “pipe within a pipe”. Flue gas exits the building through the inner pipe and combustion air is drawn into the boiler through the space between the inner and outer pipe.
- **Vertical Twin Pipe Venting** - Vent system exits the building through a roof. Combustion air and flue gas are routed between the boiler and outdoors using separate pipes.

All of these systems are considered “direct vent” because in all of them air for combustion is drawn directly from the outdoors into the boiler. A description of all of these venting options are shown in Tables 7.1 and 7.9. For clarity, these vent options are numbered from 1 to 6. One of the vent option columns in Tables 7.1 or 7.9 must match the planned vent and air intake system exactly. In addition, observe the following guidelines:

- 1) **Approved vent systems** - Use only one of the approved vent systems shown in Tables 7.4, 7.5 or explicitly approved by Crown for use with this boiler in an installation manual supplement. These vent systems fall into three basic categories:

- **Concentric Vent System** - The standard boiler is supplied with a concentric vent system having a maximum usable length of 25’ (Figure 1.1). For longer runs, additional straight lengths and elbows are available from Crown. In some cases, larger diameter concentric pipe must be used. Each Crown concentric vent component consists of an inner pipe of polypropylene and the outer pipe of steel. Integral gaskets on each concentric fitting provide a gas tight seal. A list of all Crown concentric vent components is shown in Table 7.4.

In this manual, concentric pipe sizes are called out in terms of the inner and outer pipe nominal diameters in millimeters. For example, “60/100mm” pipe consists of a 60mm exhaust pipe inside a 100mm diameter outer pipe.

- **Twin Pipe Stainless Vent Systems** - Approved vent systems are made of a special stainless steel alloy (AL29-4C) for protection against corrosive flue gas condensate. They are designed to provide a gas tight seal at all joints and seams so that flue gas does not enter the building. Each approved vent system has a unique method for installation - **do not attempt to mix components from different vent systems**. A list of approved twin pipe vent systems is shown in Table 7.5. Note that a special vent collar (Crown PN 230510) is required if the boiler is to be vented with one of the approved stainless vent systems.
- **CPVC/PVC Twin Pipe Vent System** - A twin pipe venting option using a Crown CPVC/PVC vent kit is also available. See the Crown CPVC/PVC installation manual supplement for kit part numbers and additional information.

- 2) Maximum Vent and Air Intake Lengths - The maximum length of the vent air intake piping depends upon the vent option selected and the boiler size. See Table 7.1 or 7.9 for the maximum vent length. In horizontal vent systems, the lengths shown in Table 7.1 are in addition to the first standard elbow on top of the boiler. For vertical vent systems, the maximum vertical vent lengths shown in Table 7.9 are in addition to two standard radius elbows. If more elbows are desired, the maximum allowable vent length must be reduced by the amount shown in Table 7.8 for each additional elbow used. Termination fittings are never counted, although the length of the concentric terminal section is counted.

Example:

A 60/100mm concentric vent system is planned for a horizontally vented BWC120 which has the following components:

80/125 x 60/100mm Reducing Elbow (supplied with the boiler)
5ft Straight Pipe
90 elbow
1-1/2ft Straight Pipe
45Elbow
Uncut Terminal Section (supplied with the boiler)

The Vent Option #1 column in Table 7.1 describes a horizontal direct vent system using 60/100mm concentric vent pipe. From this column, we see that a BWC120 may have a vent length of up to 18ft. The 90 degree reducing elbow is not considered. The length of the terminal section (not including the plastic terminal itself) is approximately 22 1/2" (1.9ft) installed. From Table 7.8, we see that the equivalent length of the 60/100mm elbow is 4.5ft and that the equivalent length of the 45 degree elbow is 4ft. The total equivalent length of the planned venting system is therefore:

5ft (Straight) + 4.5ft (90 Elbow) + 1.5ft (Straight) + 4 ft (45 Elbow) + 1.9ft (Uncut Terminal Section) = 16.9ft.

Since Table 7.1 shows a maximum allowable vent length of 18ft, the planned vent system length is acceptable.

- 3) Minimum Vent and Air Intake Lengths - Observe the minimum vent lengths shown in tables 7.1 and 7.9.
- 4) Permitted Terminals for Horizontal Venting:
- **Vent Option 1** - The 60/100mm concentric vent terminal is supplied with the boiler as part of the standard vent system.
 - **Vent Option 2** - The exhaust terminal is Crown PN 230511. The air intake fitting is a 90 degree elbow with a rodent screen supplied by the installer. This elbow is made out of the same material as the rest of the air inlet system (either galvanized or PVC) and is installed as shown in Figure 7.3.
 - **Vent Option 3** - Two terminals are permitted:
 - a) 80/125mm Concentric Vent Terminal (Crown PN 230531)
 - b) 80/125mm Snorkel Terminal (Crown PN 230540) . This terminal allows the vent system to exit the building close to grade and go up the exterior wall far enough to provide adequate clearance between the terminal itself and the snow line (Figure 7.7).
- 5) Horizontal Vent and Air Intake Terminal Location - Observe the following limitations on the vent terminal location (also see Figures 7.6, 7.7). When locating a concentric terminal, observe the limitations outlined below for "vent terminals".
- Vent terminals must be at least 1 foot from any door, window, or gravity inlet into the building.
 - For twin pipe terminals, maintain the correct clearance and orientation between the vent and air intake terminals. The vent and air intake terminals must be at the same height and their center lines must be between 12 and 36 inches apart. Both terminals must be located on the same wall.
 - The bottom of all terminals must be at least 12" above the normal snow line. In no case should they be less than 12" above grade level.
 - The bottom of the vent terminal must be at least 7 feet above a public walkway.
 - Do not install the vent terminal directly over windows or doors.
 - The bottom of the vent terminal must be at least 3 feet above any forced air inlet located within 10 feet.
 - USA Only: A clearance of at least 4 feet horizontally must be maintained between the vent terminal and gas meters, electric meters, regulators, and relief equipment. Do not install vent terminal over this equipment. In Canada, refer to B149.1 Installation Code for clearance to meters, regulators and relief equipment.
 - Do not locate the vent terminal under decks or similar structures.
 - Top of vent terminal must be at least 5 feet below eaves, soffits, or overhangs. Maximum depth of overhang is 3 ft.

Horizontal Terminal Clearance Requirements (continued):

- Vent terminal must be at least 6 feet from an inside corner.
- Under certain conditions, water in the flue gas may condense, and possibly freeze, on objects around the vent terminal including on the structure itself. If these objects are subject to damage by flue gas condensate, they should be moved or protected.
- If possible, install the vent and air intake terminals on a wall away from the prevailing wind. Reliable operation of this boiler cannot be guaranteed if these terminals are subjected to winds in excess of 40 mph.
- Air intake terminal must not terminate in areas that might contain combustion air contaminants, such as near swimming pools. See Section IV for more information on possible contaminants.

TABLE 7.1: SUMMARY OF HORIZONTAL VENTING OPTIONS

VENT OPTION #		1	2	3	
CLASSIFICATION USED IN THIS MANUAL		HORIZONTAL CONCENTRIC	HORIZONTAL TWIN PIPE	HORIZONTAL CONCENTRIC	
ILLUSTRATED IN FIGURE		7.2	7.3	7.2	
VENT PIPE PENETRATION THROUGH STRUCTURE		WALL	WALL	WALL	
AIR INTAKE PIPE PENETRATION THROUGH STRUCTURE		WALL	WALL	WALL	
VENT PIPE SIZE		60/100 mm	3"	80/125 mm	
AIR INTAKE PIPE SIZE		CONCENTRIC	3"	CONCENTRIC	
MAXIMUM LENGTH	VENT	BWC070	32ft	100ft	100ft
		BWC090	32ft	100ft	100ft
		BWC120	18ft	100ft	100ft
		BWC151		100ft	100ft
	INLET	BWC070	32ft	100ft	100ft
		BWC090	32ft	100ft	100ft
		BWC120	18ft	100ft	100ft
		BWC151		100ft	100ft
MINIMUM LENGTH	VENT	BWC070	10in	10in	10in
		BWC090	10in	10in	10in
		BWC120	10in	10in	10in
		BWC151		10in	10in
	INLET	BWC070	10in	10in	10in
		BWC090	10in	10in	10in
		BWC120	10in	10in	10in
		BWC151		10in	10in
VENT TERMINAL		60/100 mm CONCENTRIC	CROWN #230511	Crown 230531 CONCENTRIC or 230540 SNORKEL	
AIR INTAKE TERMINAL			3" 90 ELBOW		
VENT MATERIAL		CROWN 60/100mm VENT COMPONENTS SHOWN IN TABLE 7.4a (Note #1)	APPROVED STAINLESS STEEL VENT SYSTEM SHOWN IN TABLE 7.5	CROWN 80/125mm VENT COMPONENTS SHOWN IN TABLE 7.4b	
AIR INTAKE MATERIAL			GALVANIZED OR PVC		

Note #1: In Vent Option #1, the 80/125mm concentric straight section (PN 230515) shown in Table 7.4a may be used between the boiler and the first 80/125 x 60/100 reducing elbow. If this is done, the overall maximum vent length is still restricted to that shown for Vent Option #1 in Table 7.1 above.

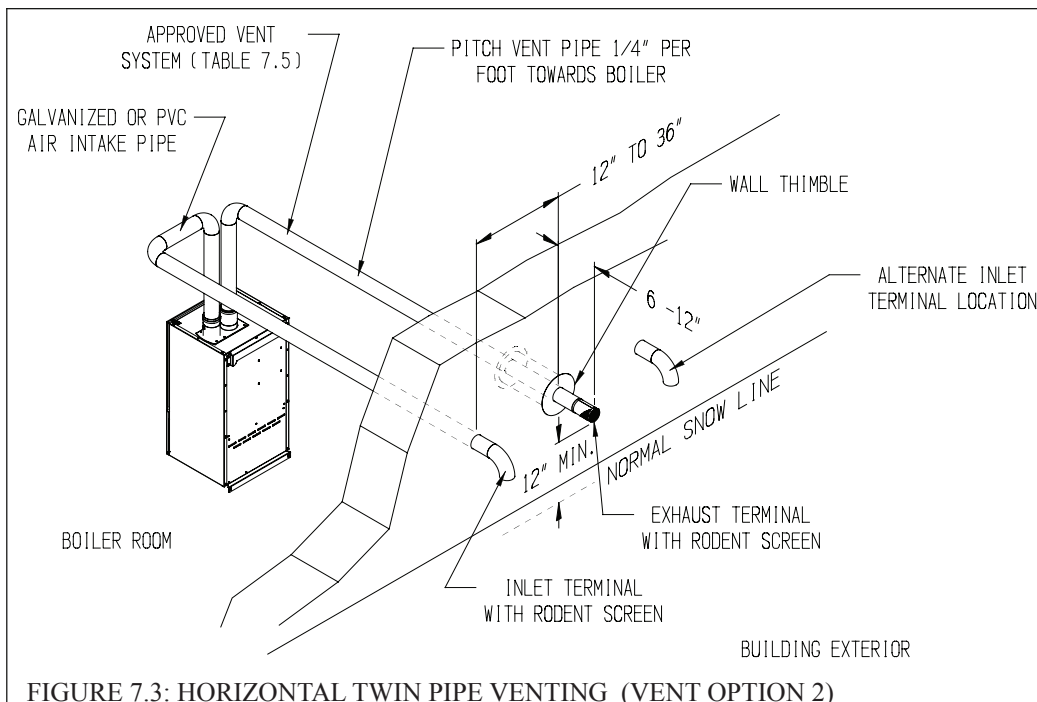
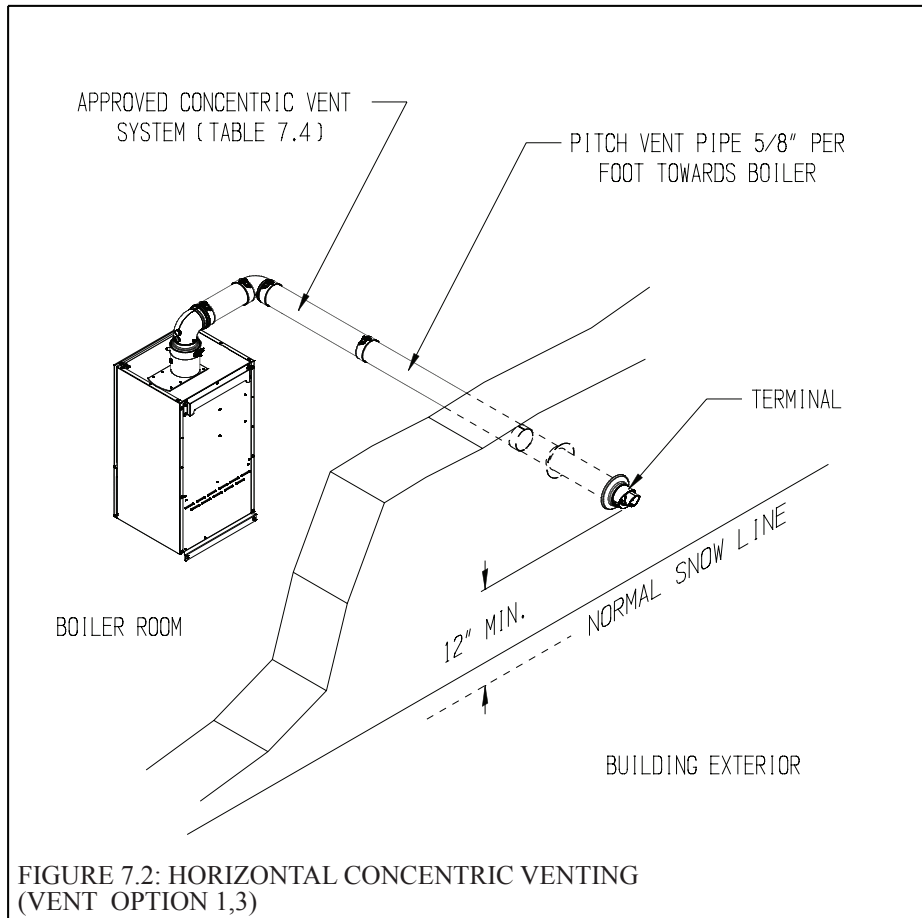

**TABLE 7.4a: CROWN CONCENTRIC 60/100 VENT COMPONENTS
(VENT OPTION 1)**

CROWN PN	DESCRIPTION	SIZE	USED ON VENT OPTION #	COMMENTS
230521	80/125 x 60/100mm REDUCING ELBOW	80/125 x 60/100mm	1	INCLUDED WITH STANDARD BWC070/090/120
230520	TERMINAL SECTION	60/100mm	1	INCLUDED WITH STANDARD BWC070/090/120
230522	WALL GROMMET	60/100mm	1	INCLUDED WITH STANDARD BWC070/090/120
230505	39" STRAIGHT	60/100mm	1	OPTIONAL - MAY NOT BE CUT
230504	78" STRAIGHT	60/100mm	1	OPTIONAL - MAY NOT BE CUT
230506	19 1/2" STRAIGHT	60/100mm	1	OPTIONAL - CAN BE CUT
230507	90 DEGREE ELBOW	60/100mm	1	OPTIONAL
230508	45 DEGREE ELBOW	60/100mm	1	OPTIONAL
230515	39" STRAIGHT	80/125mm	1	OPTIONAL - CAN BE CUT (Note #1)

Note #1: On 60/100mm vent systems, this may only be used between the boiler and the first 80/125 x 60/100 Reducing elbow (see text).

**TABLE 7.4b: CROWN CONCENTRIC 80/125 VENT COMPONENTS
(VENT OPTIONS 3,6)**

CROWN PN	DESCRIPTION	SIZE	USED ON VENT OPTION #	COMMENTS
230527	90 DEGREE EL (STANDARD)	80/125mm	3,6	
230528	90 DEGREE EL (SWEEP)	80/125mm	3,6	
230526	45 DEGREE EL	80/125mm	3,6	
230517	19 1/2" STRAIGHT	80/125mm	3,6	CAN BE CUT
230515	39" STRAIGHT	80/125mm	3,6	CAN BE CUT
230518	39" STRAIGHT	80/125mm	3,6	MAY NOT BE CUT
230519	78" STRAIGHT	80/125mm	3,6	MAY NOT BE CUT
230525	TELESCOPING STRAIGHT	80/125mm	3,6	ADJUSTABLE FROM 12-1/2" TO 16-1/2"
230531	HORIZONTAL TERMINAL	80/125mm	3	
230540	SNORKEL KIT	80/125mm	3	(NOTE #1)
230532	VERTICAL TERMINAL	80/125mm	6	(NOTE #2)
230533	FLAT ROOF FLASHING	80/125mm	6	
230535	SLOPED ROOF FLASHING	80/125mm	6	(NOTE #3)
230530	SUPPORT ELBOW WITH CHIMNEY CHASE BRACKET	80/125mm	6	(NOTE #4)
230536	SUPPORT BAND	80/125mm	3,6	

Table 7.4b Notes:

- 1) Snorkel kit includes parts needed to offset terminal on exterior wall by up to 46".
- 2) Vertical terminal can be used with either of the roof flashings listed beneath it.
- 3) Sloped roof flashing suitable for roof angles between 25 and 45 degrees.
- 4) Used at base of vertical run inside unused masonry chimney.

- 6) Permitted Terminals for Vertical Venting -
- **Vent Option 5** - A straight termination is installed in the end of the vent pipe. Vent manufacturer part numbers for these screens are shown in Table 7.5. The air inlet terminal consists of a 180 degree elbow (or two 90 degree elbows) with a rodent screen as shown in Figure 7.10.
 - **Vent Option 6** - Use Crown PN 230532 with the appropriate flashing (Table 7.4b)
- 7) Vertical Vent Terminal Locations (Vent Options 5,6) - Observe the following limitations on the location of all vertical vent terminals (see Figures 7.10, 7.11):
- The top of the vent pipe must be at least 2 feet above any object located within 10 feet.
 - For Vent Option #5, the vertical distance between top of the vent and air inlet terminal openings must be at least 12”.
 - The bottom of the air inlet terminal must be at least 12” above the normal snow accumulation that can be expected on the roof. The terminal used in Vent Option #6 has a fixed distance above the storm collar of 19”. If a greater distance is needed to provide the clearance above the snow line, build a chase on the roof and mount the vertical terminal on top of the chase.
 - For Vent Option #5, the air intake terminal must be located on the roof and must be no further than 24” horizontally from the exhaust pipe.
- 8) Wall thimbles – Wall thimbles are required where single wall vent pipe passes through combustible walls with less than the required clearance shown in Table 4.2 or as required by local codes. Stainless vent manufacturer’s wall thimble part numbers are shown in Table 7.5. Note that concentric vent has a “zero” clearance to combustibles and therefore does not require the use of wall thimbles.

**TABLE 7.5: PERMISSIBLE STAINLESS STEEL VENT SYSTEMS
AND PRINCIPLE VENT COMPONENTS
(VENT OPTIONS 2, 5)**

MANUFACTURER	VENT SYSTEM	SIZE	COMPONENT	PART NUMBER
HEAT FAB	SAF-T VENT EZ SEAL	3	BOILER COLLAR	CROWN 230510
		3	WALL THIMBLE	HEAT FAB 7393, 7393GCS, 5391CI
		3	HORIZONTAL TERMINAL	CROWN 230511
		3	VERTICAL TERMINAL	HEAT FAB 9392
PROTECH SYSTEMS INC.	FASNSEAL	3	BOILER COLLAR	CROWN 230510
		3	WALL THIMBLE	FSWT3
		3	HORIZONTAL TERMINAL	CROWN 230511
		3	VERTICAL TERMINAL	FSBS3
Z-FLEX	SVE SERIES III ("Z-VENT III")	3	BOILER COLLAR	CROWN 230510
		3	WALL THIMBLE	2SVSWTEF03
		3	HORIZONTAL TERMINAL	CROWN 230511
		3	VERTICAL TERMINAL	24SVSTPF03
METAL-FAB	CORR/ GUARD	3	BOILER COLLAR	CROWN 230510
		3	WALL THIMBLE	CGSWWPK(3")
		3	HORIZONTAL TERMINAL	CROWN 230511
		3	VERTICAL TERMINAL	CGSWHTM(3")

NOTES:

- 1) See vent system manufacturer’s literature for other part numbers that are required such as straight pipe, elbows, firestops and vent supports.
- 2) Crown 230510 collar replaces factory-mounted concentric collar (Figure 7.46).

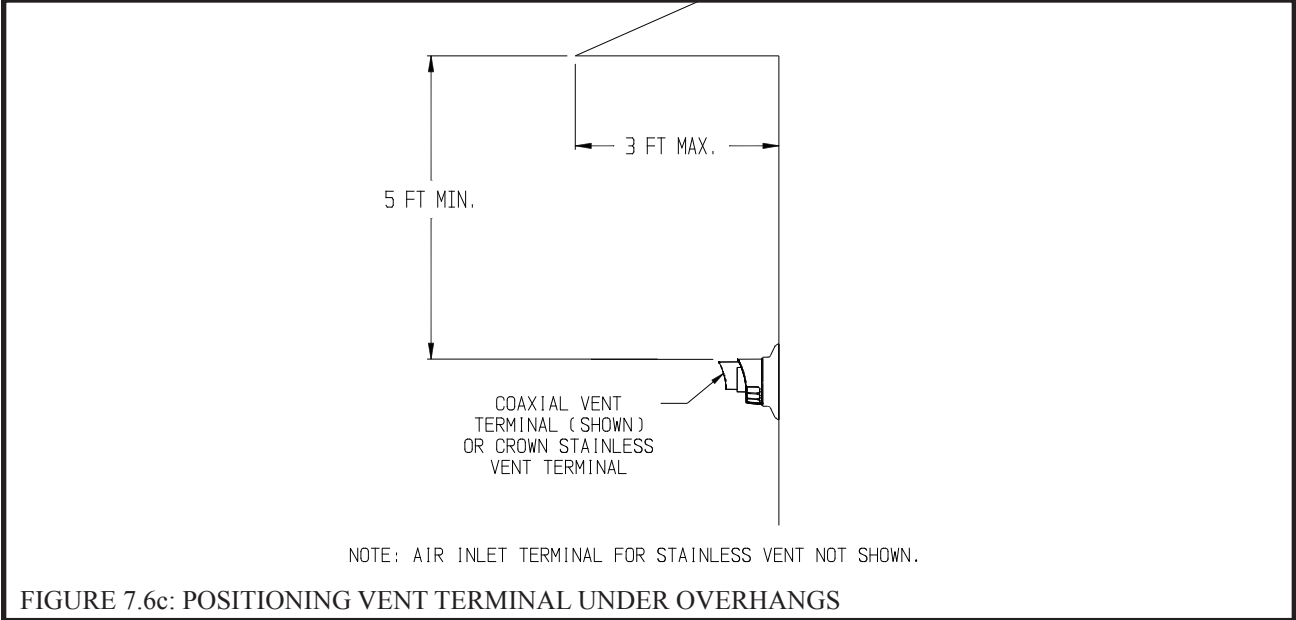
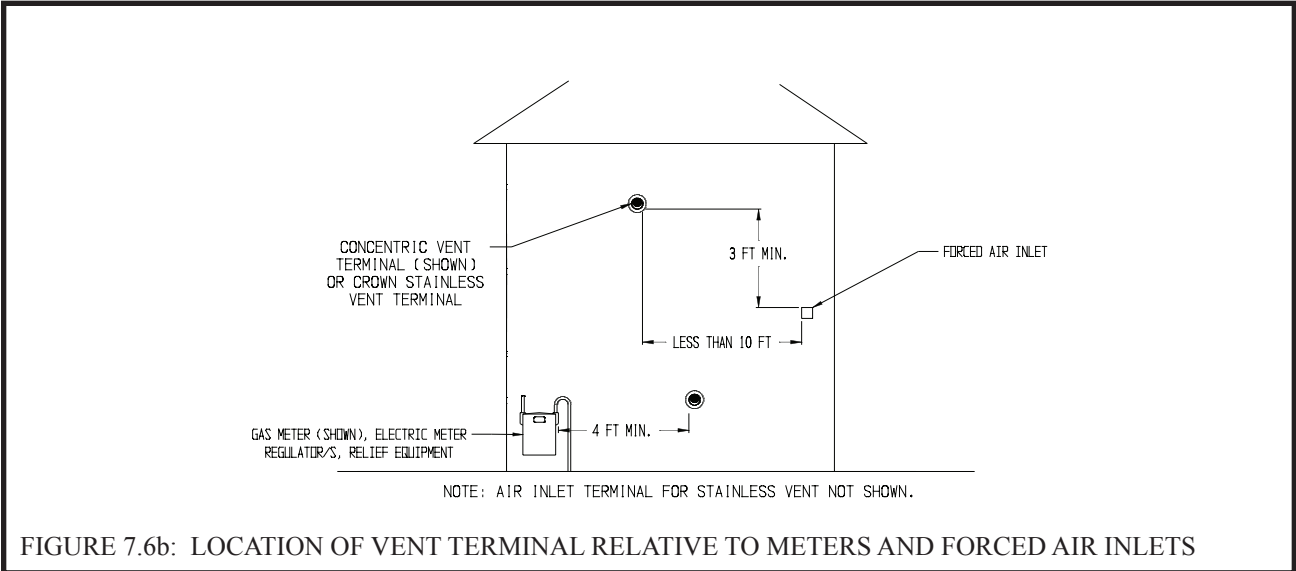
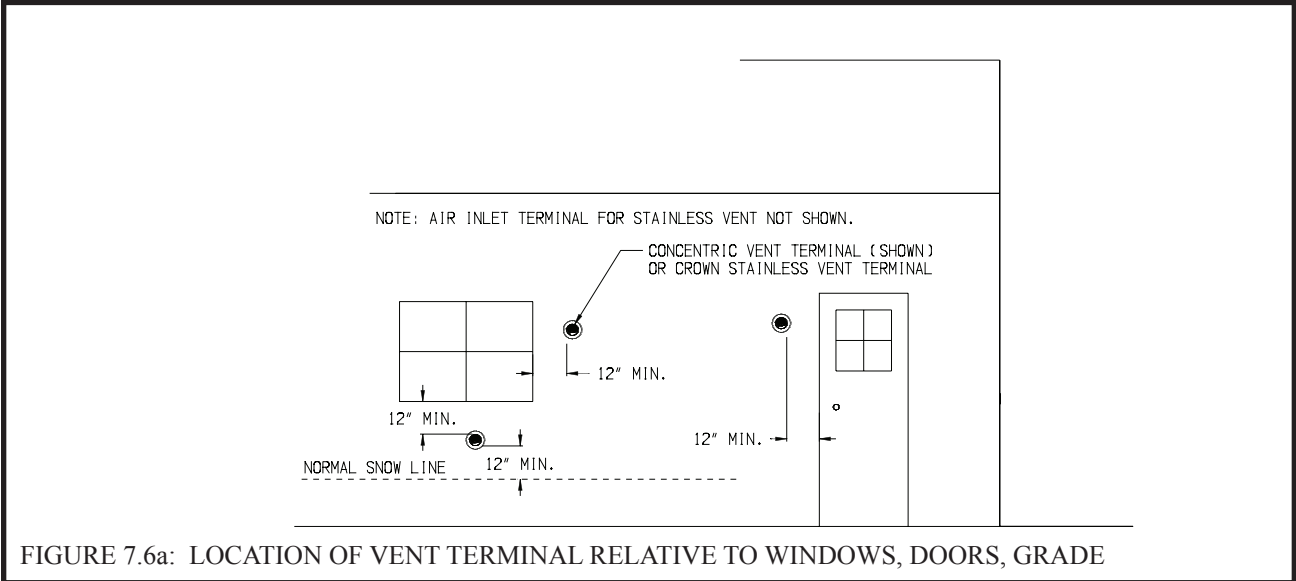

9) Pitch of Horizontal Piping - Pitch all horizontal piping so that any condensate which forms in the piping will run towards the boiler:

- Pitch Crown horizontal concentric venting 5/8" per foot (53mm/m).
- Pitch Stainless steel venting 1/4" per foot (21mm/m).

10) Supporting Pipe - Vertical and horizontal sections of pipe must be properly supported:

- Support Crown concentric venting near the female end of each straight section of pipe.

Exception: Vertical runs of concentric pipe in an unused chimney (Figure 7.36) need only be supported at the terminal and at the base of the run.

- Support stainless steel venting as called for by the vent manufacturer's instructions.

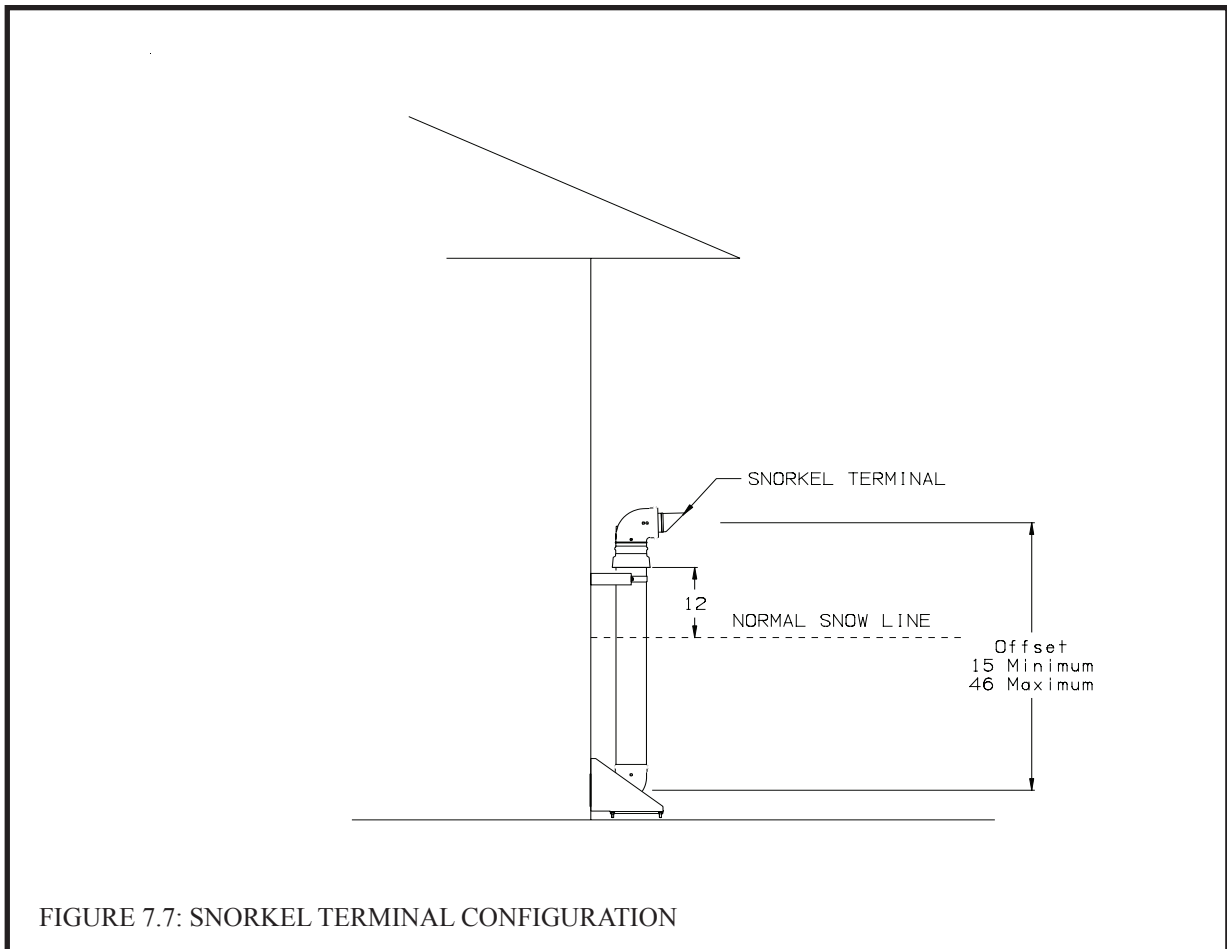

FIGURE 7.7: SNORKEL TERMINAL CONFIGURATION

TABLE 7.8: VENT/ AIR INTAKE FITTING EQUIVALENT LENGTH

VENT FITTING	EQUIVALENT LENGTH (ft)
60/100mm 90° CONCENTRIC ELBOW	4.5
60/100mm 45° CONCENTRIC ELBOW	4.0
80/125mm 90° CONCENTRIC ELBOW	8.5
80/125mm 90° SWEEP CONCENTRIC ELBOW	5.5
80/125mm 45° CONCENTRIC ELBOW	3.0
80/125mm 90° CONCENTRIC SUPPORT ELBOW	8.5
3” SINGLE WALL 90° ELBOW	5.5
3” SINGLE WALL 45° ELBOW	4.0

TABLE 7.9: SUMMARY OF VERTICAL VENTING OPTIONS

VENT OPTION #		5	6	
CLASSIFICATION USED IN THIS MANUAL		VERTICAL TWIN PIPE	VERTICAL CONCENTRIC	
ILLUSTRATED IN FIGURE		7.10	7.11	
VENT PIPE PENETRATION THROUGH STRUCTURE		ROOF	ROOF	
AIR INTAKE PIPE STRUCTURE THROUGH STRUCTURE		ROOF	ROOF	
VENT PIPE SIZE		3”	80/125 mm CONCENTRIC	
AIR INTAKE PIPE SIZE		3”		
MAXIMUM LENGTH	VENT	BWC070	98ft	95ft
		BWC090	98ft	95ft
		BWC120	98ft	95ft
		BWC151	98ft	95ft
	INLET	BWC070	98ft	95ft
		BWC090	98ft	95ft
		BWC120	98ft	95ft
		BWC151	98ft	95ft
MINIMUM LENGTH	VENT	BWC070	2ft	2ft
		BWC090	2ft	2ft
		BWC120	2ft	2ft
		BWC151	2ft	2ft
	INLET	BWC070	2ft	2ft
		BWC090	2ft	2ft
		BWC120	2ft	2ft
		BWC151	2ft	2ft
VENT TERMINAL		STRAIGHT TERMINAL BY VENT SYSTEM MFR. (TABLE 7.5)	CROWN #230532 CONCENTRIC TERMINAL (TABLE 7.4b)	
AIR INTAKE TERMINAL		3” 180° ELBOW (FIGURE 7.10)		
VENT MATERIAL		APPROVED STAINLESS STEEL VENT SYSTEM	CROWN 80/125 mm VENT COMPONENTS SHOWN IN TABLE 7.4b	
AIR INTAKE MATERIAL		GALVANIZED OR PVC		

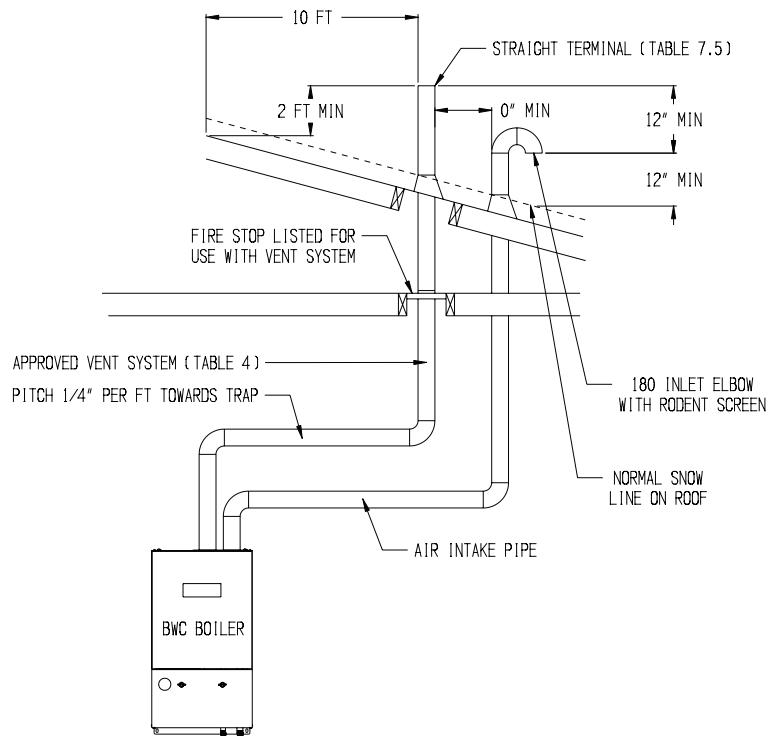

FIGURE 7.10: VERTICAL TWIN PIPE VENT SYSTEM (VENT OPTION 5)

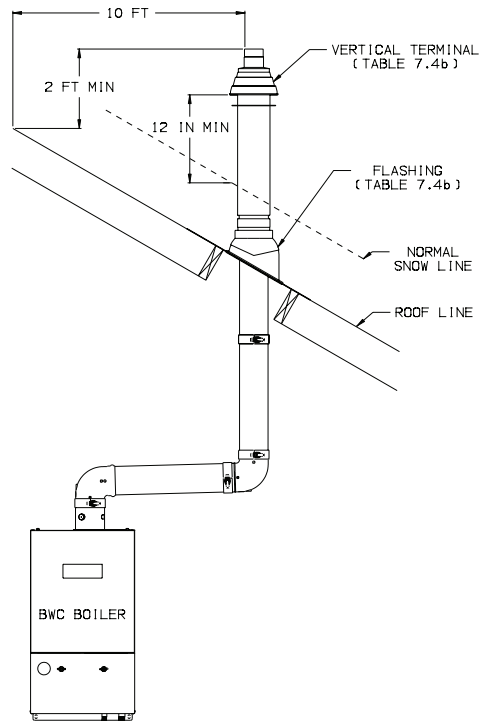

FIGURE 7.11: VERTICAL CONCENTRIC VENT SYSTEM (VENT OPTION 6)

B. Removing an Existing Boiler From a Common Chimney

Read this only if the BWC boiler is replacing an existing boiler that is being removed from a common chimney. This section does not apply to the installation of a BWC boiler.

In some cases, when an existing boiler is removed from a common chimney, the common venting system may be too large for the remaining appliances. At the time of removal of an existing boiler, the following steps shall be followed with each appliance remaining connected to the common venting system placed in operation, while the other appliances remaining connected to the common venting system are not in operation.

- (a) Seal any unused openings in the common venting system.
- (b) Visually inspect the venting system for proper size and horizontal pitch and determine there is no blockage or restriction, leakage, corrosion and other deficiencies which could cause an unsafe condition.
- (c) Insofar as practical, close all building doors and windows and all doors between the space in which all the appliances remaining connected to the common venting system are located and other spaces of the building. Turn on clothes dryers and any appliance not connected to the common venting system. Turn on any exhaust fans, such as range hoods and bathroom exhausts, so they will operate at maximum speed. Do not operate a summer exhaust fan. Close fireplace dampers.
- (d) Place in operation the appliance being inspected. Follow the lighting instructions. Adjust thermostat so the appliance will operate continuously.
- (e) Test for spillage at the draft hood relief opening after 5 minutes of main burner operation. Use the flame of a match or candle, or smoke from a cigarette, cigar, or pipe.
- (f) After it has been determined that each appliance remaining connected to the common venting system properly vents when tested as outlined above, return doors, windows, exhaust fans, fireplace dampers and any other gas-burning appliances to their previous condition of use.
- (g) Any improper operation of the common venting system should be corrected so the installation conforms with the National Fuel Gas Code, ANSI Z223.1 or CSA/CAN B149.1, as appropriate. When re-sizing any portion of the common venting system, the common venting system should be re sized to approach the minimum size as determined using the appropriate tables in Part 11 of the National Fuel Gas Code, ANSI Z223.1.

WARNING

NEVER COMMON VENT A BWC BOILER WITH OTHER APPLIANCES.

C. Assembly of Crown 60/100mm Concentric Venting
(IMPORTANT - Skip to Section D for 80/125mm Concentric Vent Assembly)

WARNING

Failure to follow the instructions could result in flue gas leakage into the combustion air or indoor air, resulting in unsafe or unreliable operation.

- **Do not lubricate concentric gaskets with anything other than water.**
- **Do not attempt to cut any piping except as permitted in this section. When cutting these sections, make sure all cuts are square and allow for proper insertion.**
- **Do not attempt to try to mix this concentric pipe with other venting systems.**

- 1) Concentric vent components supplied with the boiler are packed inside the BWC070/090/120 carton and include the following:
 - a) 80/125 x 60/100mm reducing elbow (Crown PN 230521).
 - b) 60/100mm terminal section (straight section with a terminal and overall length of 27 3/4" (Crown PN 230520).
 - c) Two (2) Rubber wall grommets (Crown PN 230522).
- 2) Unless the 80/125 straight riser (PN 230515) is used, start by attaching the reducing elbow to the boiler collar. To do so, remove the clamp from the large end of the reducing elbow and set aside. Apply a small amount of water to the brown gasket on the boiler collar. Push the elbow onto the boiler collar until the bead on the elbow contacts the top edge of the collar (Figure 7.20).
- 3) Reinstall the clamp removed in Step (2) so that the elbow is secured to the boiler collar.
- 4) If no additional sections of concentric pipe are required, attach the terminal section to the elbow. In most cases, it will need to be cut before doing so. Use the following procedure to cut the pipe:
 - a) Measure distance "L" from the outside surface of the exterior wall to the end of the elbow as shown in Figure 7.21.
 - b) Add 2-1/8" to distance "L". Carefully mark this length on the pipe as shown in Figure 7.22.
 - c) Press in the two tabs holding the plastic terminal in the terminal section (Figure 7.22). Carefully pull out the terminal and the inner pipe.
 - d) Cut the **outer pipe only** at the point marked in Step (b) using aviation shears, a hacksaw, or an abrasive wheel cutter. Be careful to cut the pipe square. De burr the cut end with a file or emery cloth.
 - e) Cut the plastic inner pipe so that it will protrude 3/8" beyond the outer pipe when reinstalled in the terminal section (Figure 7.23). Use a fine tooth hacksaw or a PVC saw to cut the plastic pipe and be careful to cut the pipe square. De burr the cut edge of the plastic pipe with a file, razor blade, or fine sandpaper.
 - f) Reinstall the inner pipe in the terminal section. Slip the outside wall grommet over the terminal section and position so that it covers the joint between the outer pipe and the terminal (Figure 7.24).
 - g) Make a mark on the terminal section 1" from the cut end of the outer pipe as shown in Figure 7.24.
 - h) Pass the terminal section through the wall from the outside. Push the remaining wall grommet over the terminal section on the inside of the wall. Push the terminal section into the elbow until the mark made in Step (g) is no longer visible. If necessary, the brown gasket in the inner pipe may be lubricated with a few drops of water.
 - i) The terminal section must be attached to the elbow with a single #10 x 1/2" sheet metal screw (not supplied) at the top of the elbow. Drill a 1/8" hole in the location shown in Figure 7.25. **Use a short drill bit or a drill stop to ensure that the drill bit does not penetrate the pipe by more than 3/8"**. Install a #10 x 1/2" screw in this hole. **Do not use a screw longer than 1/2" long.**
 - j) If not already done, make sure that both wall grommets are firmly against the interior and exterior wall surfaces. Seal any cracks or other openings near the terminal through which exhaust could enter the building.
- 5) If additional pieces of pipe are used, install them starting at the boiler elbow. Support each section of straight pipe at its female end.

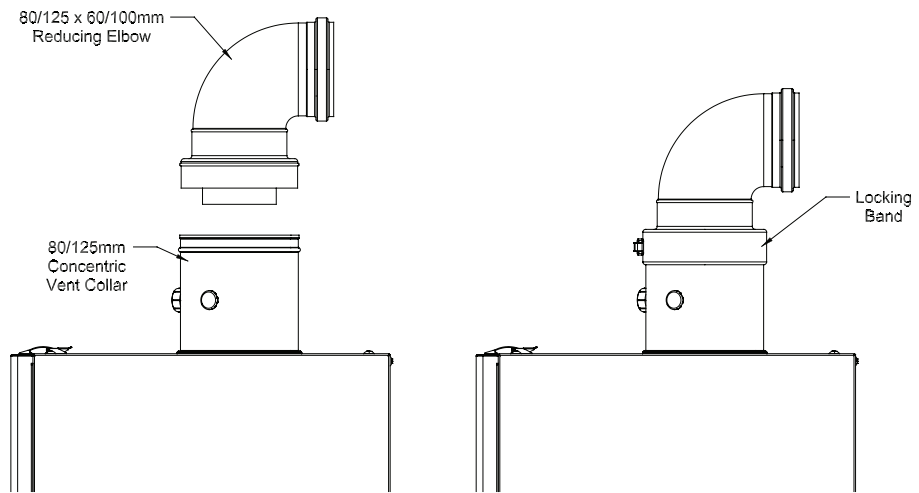

FIGURE 7.20: INSTALLATION OF REDUCING ELBOW ON CONCENTRIC BOILER COLLAR

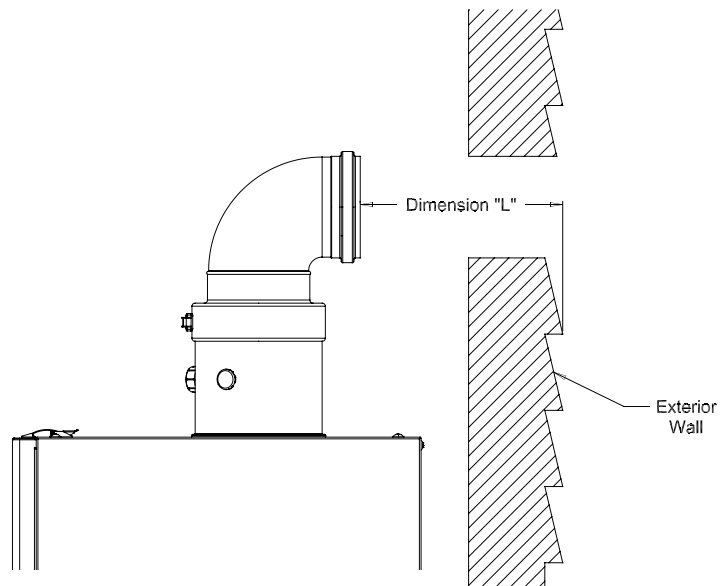

FIGURE 7.21: DIMENSION "L"

- 6) Use locking bands provided to join adjacent sections of non-cuttable pipe as well as fittings. The male end of the terminal section and other cuttable sections must be held to the female end of the adjoining pipe with at least three #10 x 1/2" sheet metal screws. Drill a 1/8" hole through both outer pipes to start this screw. **Use a drill stop or other means to ensure that the drill bit does not penetrate more than 3/8" into the outer pipe. Do not use a sheet metal screw longer than 1/2".**
- 7) The only straight pipe that can be cut is the terminal section, the 19-1/2" section (Crown PN 230506) and the 80/125 straight riser (PN230515). To cut this pipe:
- Cut pipe from the male end. After marking the desired length of the outer pipe, remove the plastic inner pipe by pulling it out from the female end.
 - Cut the **outer pipe only** at the point marked in Step (b) using aviation shears, a hacksaw, or an abrasive wheel cutter. Be careful to cut the pipe square. De burr the cut end with a file or emery cloth.
 - Cut the plastic inner pipe so that it will protrude 3/8" beyond the outer pipe when reinstalled in the outer pipe. Use a fine tooth hacksaw or a PVC saw to cut the plastic pipe and be careful to cut the pipe square. De burr the cut edge of the plastic pipe with a file, razor blade, or fine sandpaper.
 - Reinstall the inner pipe.
- 8) Install the terminal as outlined in Step (4) above. Dimension "L" described in Step 4 is the distance from the exterior surface of the wall to the end of the last piece of pipe inside the building.

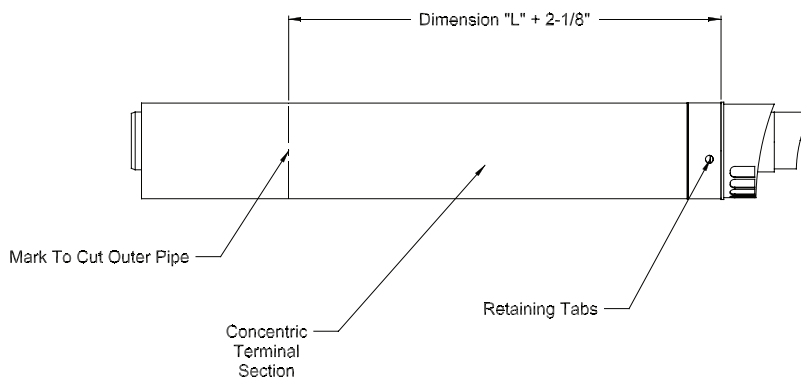

FIGURE 7.22: CUTTING OUTER PIPE

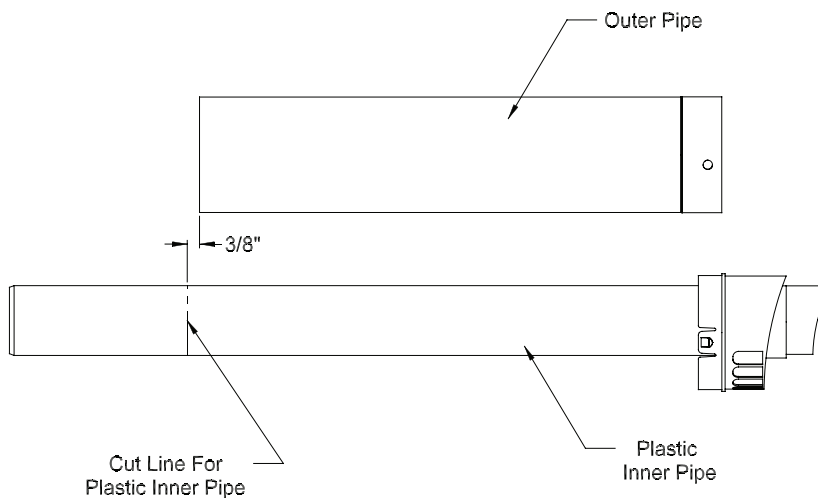

FIGURE 7.23: CUTTING INNER PIPE

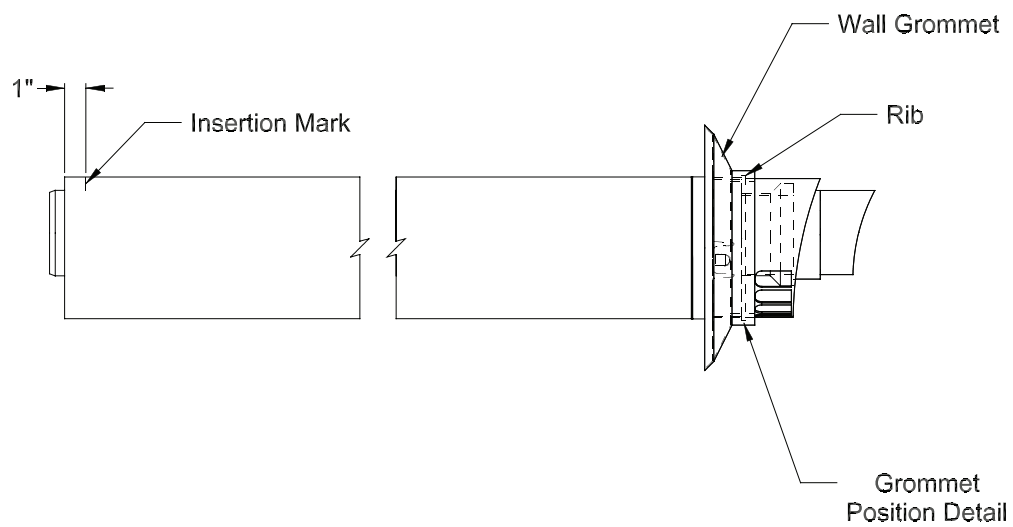

FIGURE 7.24: PREPARING 60/100mm TERMINAL SECTION FOR INSTALLATION IN THE WALL

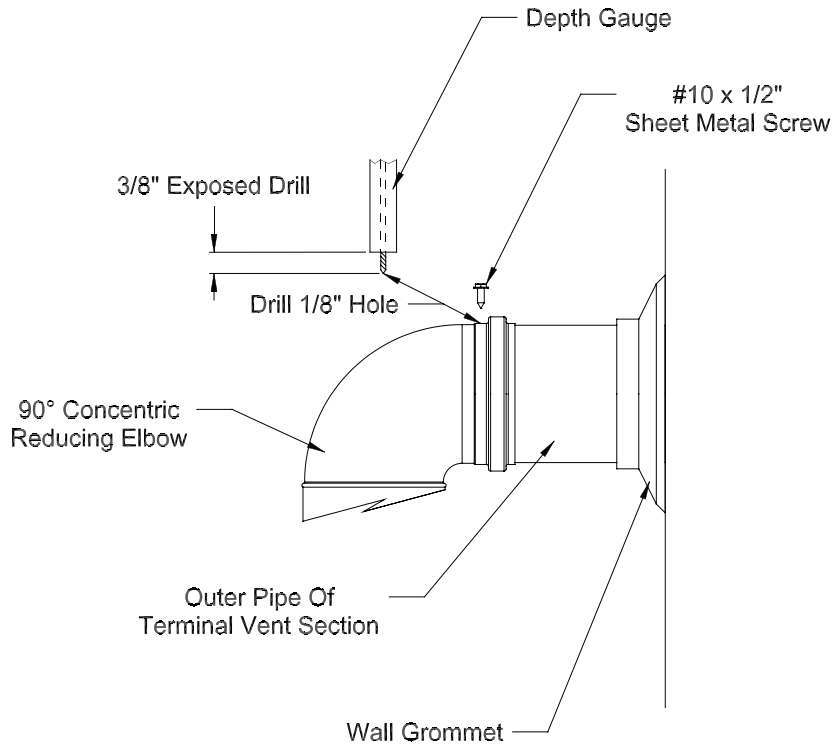

FIGURE 7.25: ATTACHING 60/100mm TERMINAL SECTION

D. Assembly of Crown 80/125mm Concentric Venting
(IMPORTANT - See Section C for 60/100mm Concentric Vent Assembly)

WARNING

Failure to follow the instructions could result in flue gas leakage into the combustion air or indoor air, resulting in unsafe or unreliable operation.

- Do not lubricate concentric gaskets with anything other than water.
- Do not attempt to cut any piping except as permitted in this section. When cutting these sections, make sure all cuts are square and allow for proper insertion.
- Do not attempt to try to mix this concentric pipe with other venting systems.

1) When BWC070, BWC090, or BWC120 boilers are vented using 80/125 venting, the 60/100 terminal section and reducing elbow supplied with the boiler are not used. The components listed in Table 7.4b are required for 80/125mm installations and are not supplied.

The BWC151 is supplied with the following 80/125 components:

- a) 80/125 Standard Radius Elbow
- b) 80/125 Terminal Section

Before starting assembly of an 80/125 vent system, make sure that the planned installation is in accordance with the “Vent System Design” Section of this manual and that all required 80/125mm vent components are on hand. Any components not supplied with the boiler are available through Crown distributors.

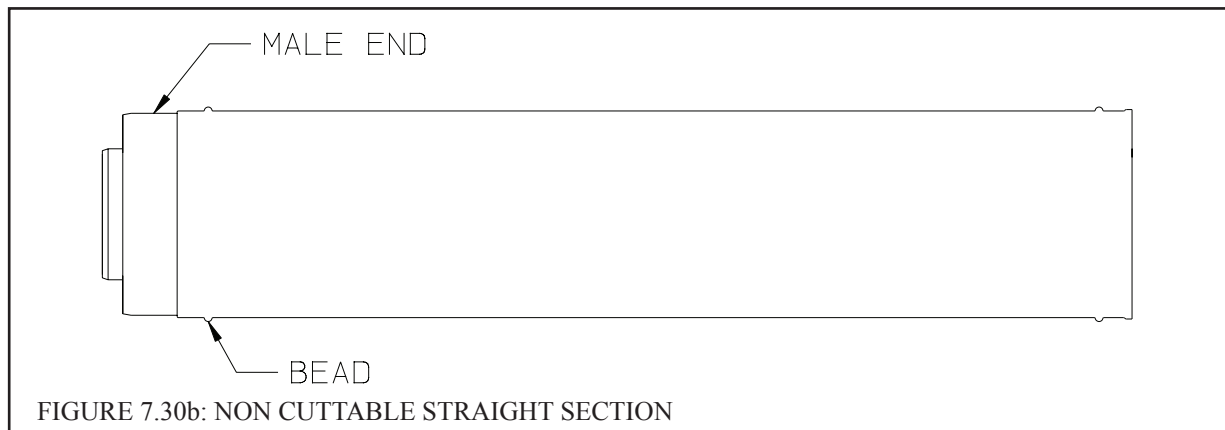
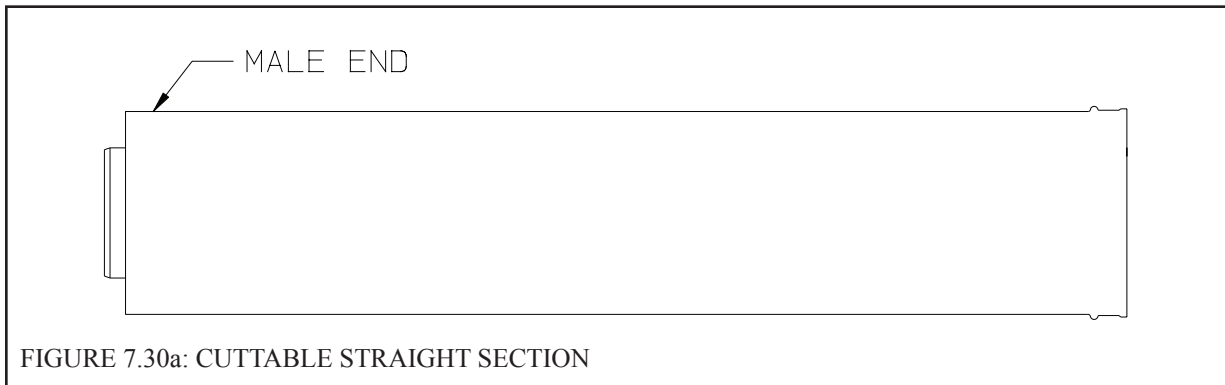

2) Cutting Straight Pipe - The following straight pipe sections may be cut:

<u>Part #</u>	<u>Description</u>
230517	19 1/2" Straight
230515	39" Straight

These sections have a plain male end (without beads - see Figure 7.30a). They are always cut from the male end. Sections not shown on the above list may not be cut. These sections have beads on the male end (Figure 7.30b).

To cut the straight sections listed above refer to Figure 7.31 and the following instructions:

- Determine the required length of the outer pipe. When doing this allow an additional 1" of length for insertion into the female end of the adjoining pipe. Mark the cut line on the outer pipe.
- Remove the plastic inner pipe by pulling it out from the female end.
- Cut the **OUTER PIPE ONLY** at the point marked in Step (a) using aviation shears, a hacksaw, or an abrasive wheel cutter. Be careful to cut the pipe square. De burr the cut end with a file or emery cloth.
- Make an insertion mark 1" from the male end of the outer pipe.
- Cut the plastic inner pipe so that it will protrude 3/8" beyond the male end of the outer pipe when reinstalled in the outer pipe. Use a fine tooth hacksaw or a PVC saw to cut the plastic pipe and be careful to cut the pipe square. De burr the cut edge of the plastic pipe with a file, razor blade, or fine sandpaper.
- Reinstall the inner pipe.

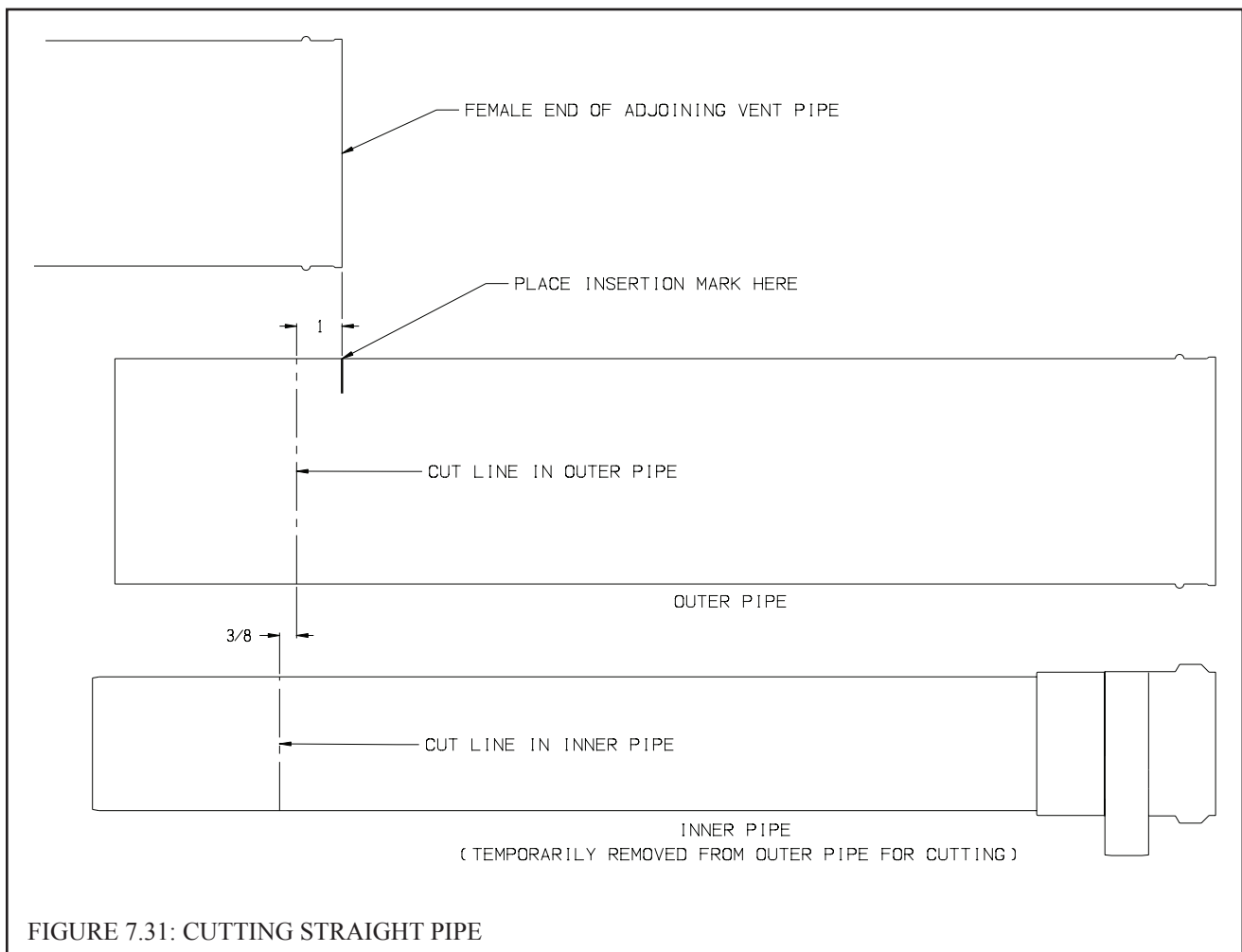

FIGURE 7.31: CUTTING STRAIGHT PIPE

3) Joining Pipe -

- a) Start assembly of the vent system at the boiler. Lubricate the brown gasket in the boiler vent collar with a few drops of water.
- b) Push the male end of the first fitting into the boiler collar until it bottoms out. The male end of cuttable sections should go 1" into the collar until the insertion mark (made in Step 2d above) is covered. On other fittings, the bead on the male pipe will bottom out on the collar (Figure 7.32b).
- c) The male end of cuttable fittings must be held to the collar with three #10 x 1/2" sheet metal screws. Drill a 1/8" hole through both outer pipes to start this screw. Use a drill stop or other means to ensure that the drill bit does not penetrate more than 3/8" into the outer pipe. Do not use a sheet metal screw longer than 1/2" (Figure 7.32a).
- d) Use locking bands (provided with all fittings) to secure non-cuttable pipe, as well as fittings, to the boiler collar (Figure 7.32b).
- e) Use the same method to join all remaining vent components except for the terminal.

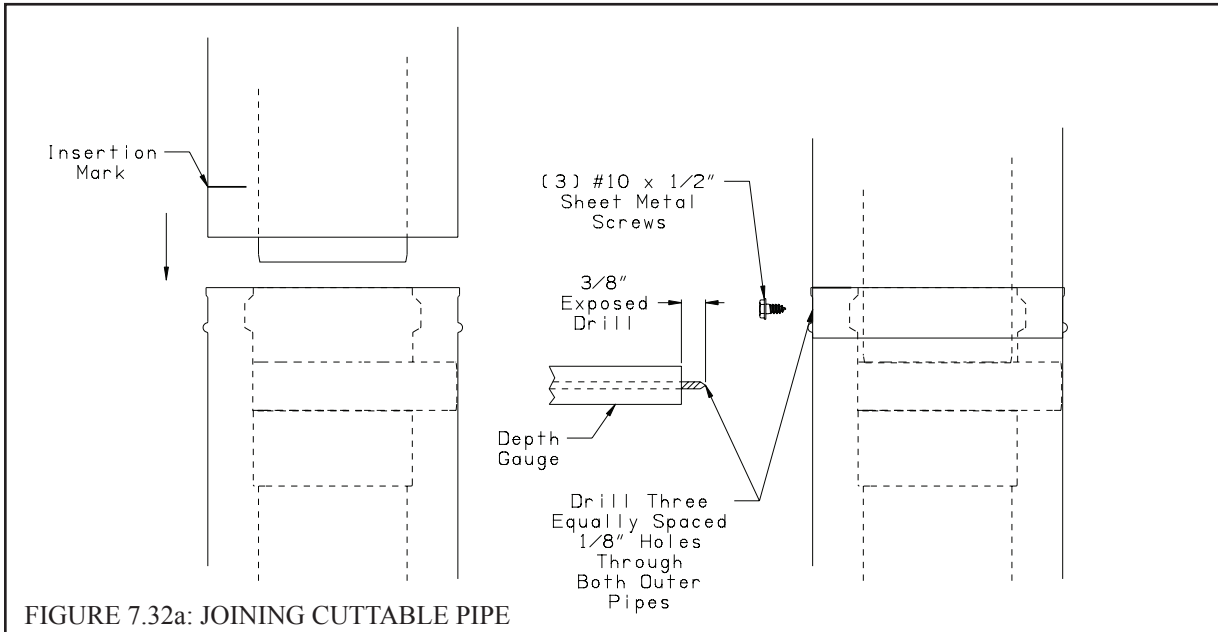

FIGURE 7.32a: JOINING CUTTABLE PIPE

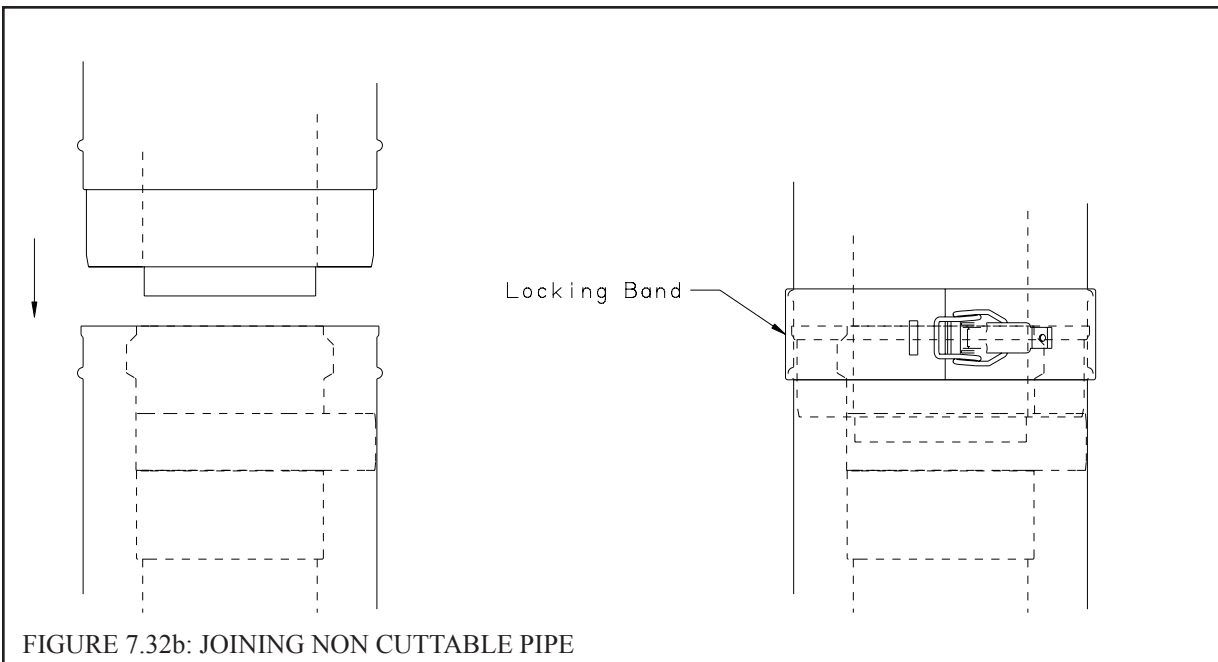

FIGURE 7.32b: JOINING NON CUTTABLE PIPE

4) 80/125mm Horizontal Terminal Installation -

- a) Cut a 5-1/2" diameter hole through the exterior wall at the planned location of the horizontal terminal.
- b) Measure distance "L" from the outside surface of the exterior wall to the end of the last fitting as shown in Figure 7.33a.
- c) Add 1-1/4" to distance "L". Carefully mark this length on the pipe as shown in Figure 7.33b.
- d) Remove the plastic inner pipe from the terminal by gently pulling on it from the male end. Set aside.
- e) Cut the **outer pipe only** at the point marked in Step (c) using aviation shears, a hacksaw, or an abrasive wheel cutter. Be careful to cut the pipe square. De-burr the cut end with a file or emory cloth.
- f) Reinstall the plastic inner pipe in the terminal, making sure that the female end of this pipe is completely bottomed out over the aluminum male connection visible behind the air intake grill. Place a mark on the plastic inner pipe 3/8" beyond the end of the outer pipe (Figure 7.33c). Use a fine tooth hacksaw or a PVC saw to cut the plastic pipe and be careful to cut the pipe square (if necessary, the plastic pipe can be removed from the terminal again for cutting). De-burr the cut edge of the plastic pipe with a file, razor blade, or fine sandpaper.
- g) Make a mark on the terminal section 1" from the cut end of the outer pipe as shown in Figure 7.33c.
- h) Slip the terminal section through the wall from the outside. Pass the terminal through the inner wall plate and push into the last section of vent pipe until the mark made in Step (h) is not longer visible (Figure 7.33d). Secure the terminal to the last piece of pipe with three #10 x 1/2" sheet metal screws. Drill a 1/8" hole through both outer pipes to start these screws. **Use a drill stop or other means to ensure that the drill bit does not penetrate more than 3/8" into the outer pipe. Do not use a sheet metal screw longer than 1/2".**
- i) Slip the outer wall plate over the terminal and secure to the wall (Figure 7.33d). Apply a 1/8" bead of weather resistant RTV over the joint between the outside wall plate and the terminal. Secure the other wall plate to the inside wall.

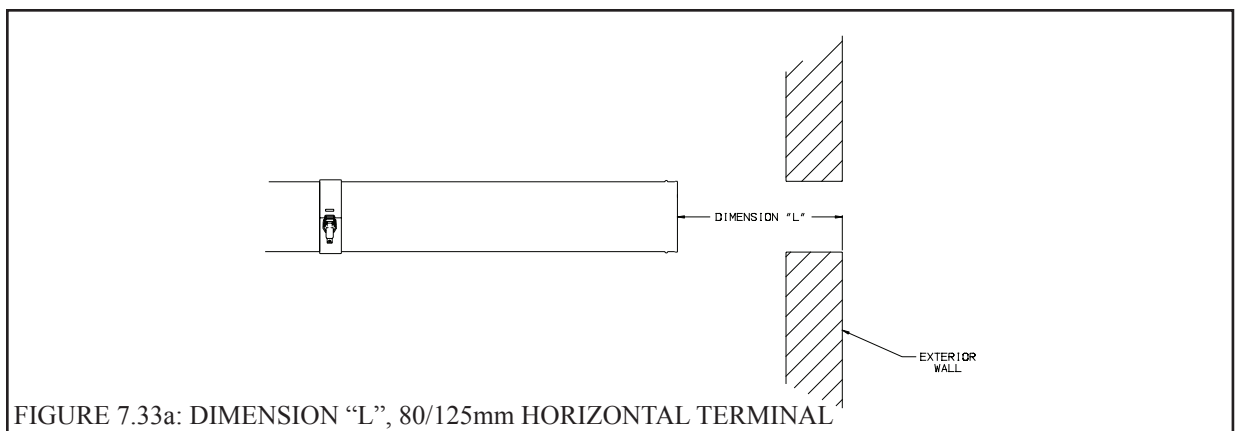

FIGURE 7.33a: DIMENSION "L", 80/125mm HORIZONTAL TERMINAL

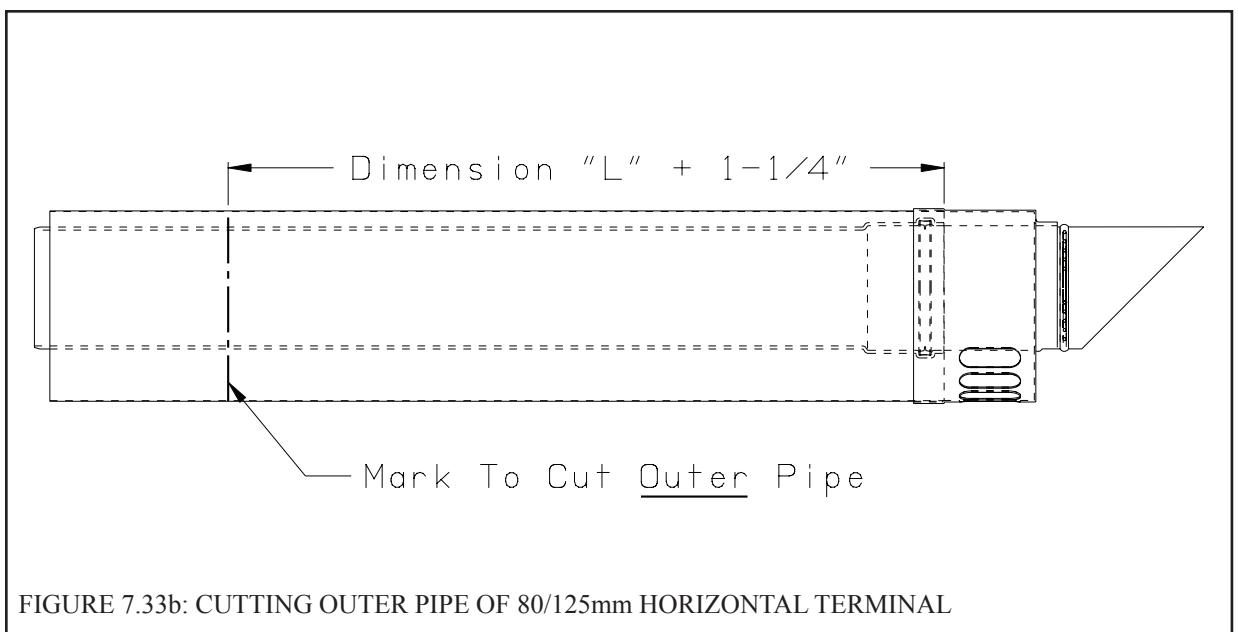
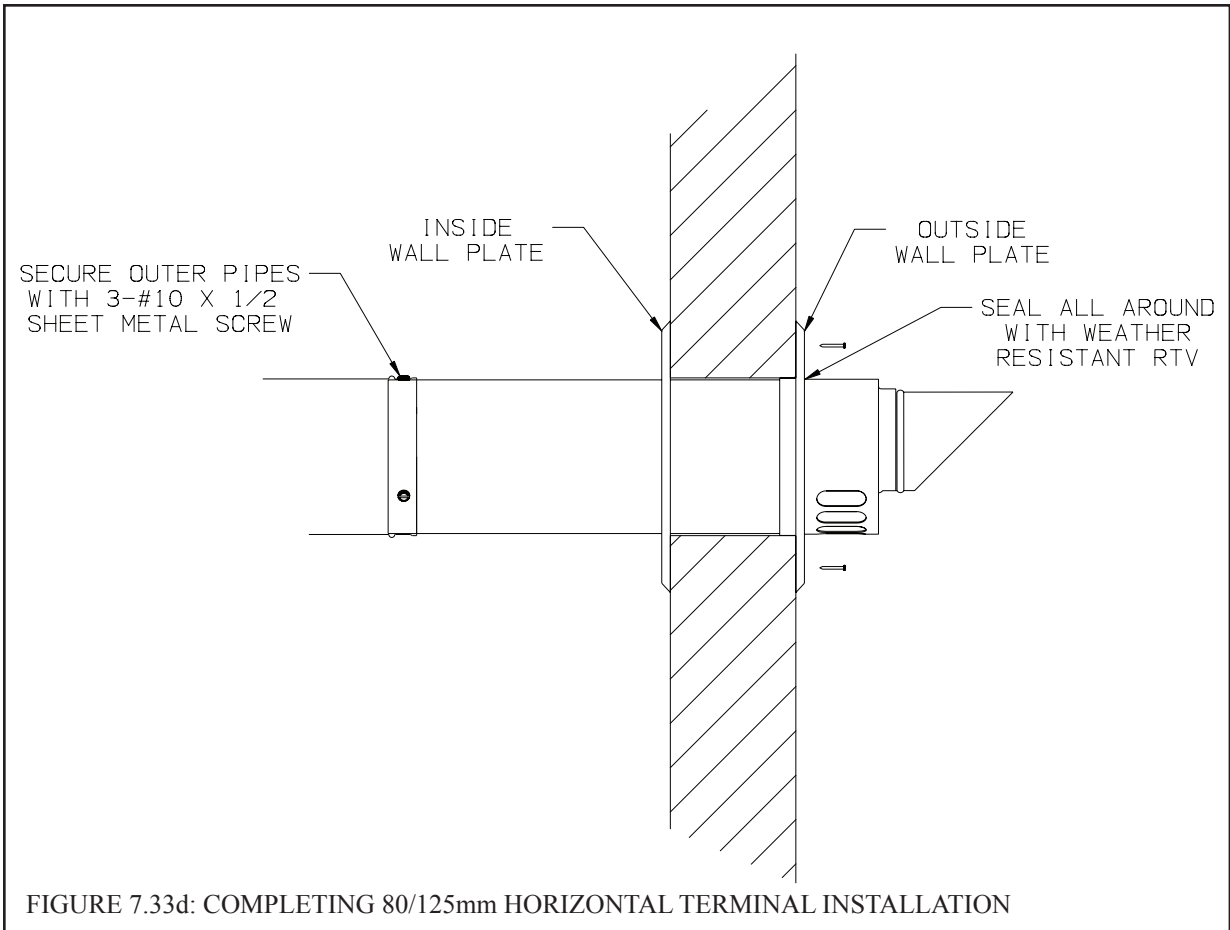
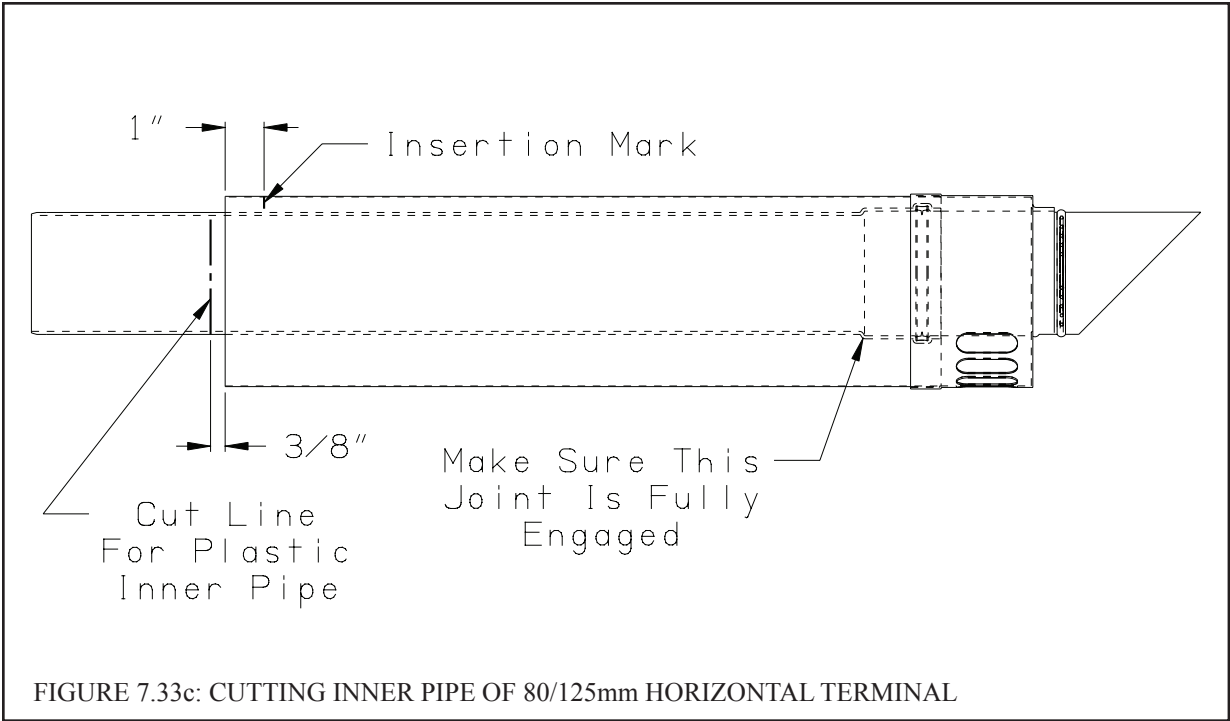

FIGURE 7.33b: CUTTING OUTER PIPE OF 80/125mm HORIZONTAL TERMINAL



5) Snorkel Terminal Installation - The Snorkel Kit (PN 230540) consists of the following (Also see Figure 7.34):

Key #	Part #	Description
1	230541	Support Elbow
2	230542	Lower Wall Bracket
3	230543	Air Intake Section
4	230544	Wall Bracket
5	230545	Terminal Elbow
6	230546	Exhaust Terminal
7	230527	Standard Elbow
8	230547	Wall Penetration Section
*	230548	Outer Joint Gasket (2 provided)

IMPORTANT

The Terminal Elbow and Wall Penetration Section included in the snorkel kit have gaskets in the female end of the outer pipe. These gaskets prevent infiltration of rain water into the air intake section. Do not interchange with similar components shown in Table 7.4b.

- Cut a 6" diameter hole through the exterior wall at the planned exit point of the vent. A minimum of 4" is needed between the center line of this hole and grade to install the lower wall bracket.
- Before mounting the lower wall bracket, loosen the M10 x 35 screw on this bracket. Adjust this bolt forward or backward so that its center is 6-7/16" from the wall (Figure 7.34) and tighten.
- Center the Lower Wall Bracket on the hole in the wall and mark the location of the four mounting screws on the wall. 5/16" mounting screws (not supplied) are recommended for mounting this bracket. Drill mounting holes and mount the bracket.

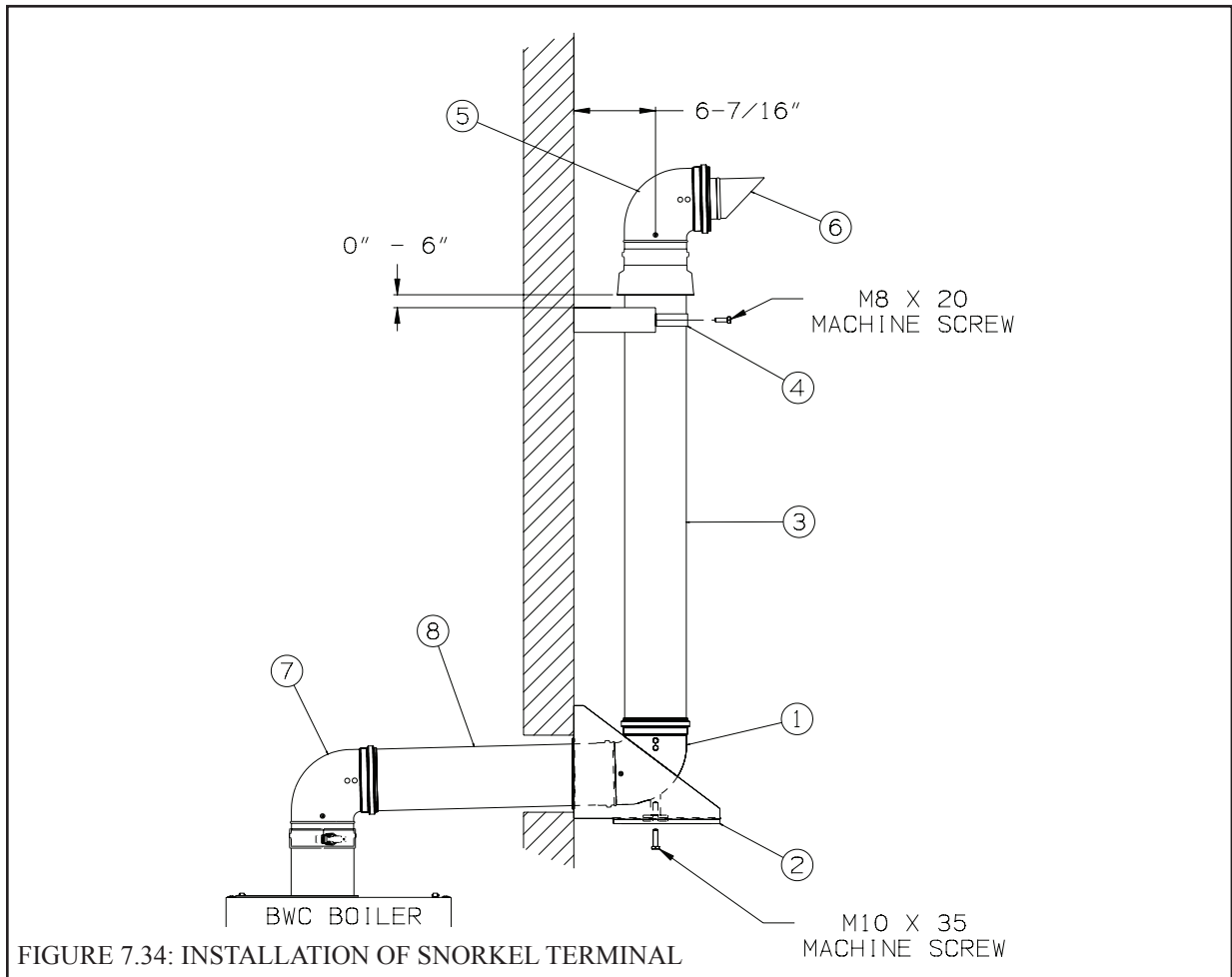

- d) Complete the vent system inside the structure. The support elbow sits on the M10 x 35 screw as shown in Figure 7.34. Cut the Wall Penetration Section to the length required to connect the interior vent system to the Support Elbow following the instructions on Page 26.
 - e) Remove the Support Elbow from the Lower Support Bracket and attach it to the Wall Penetration Section. Slip this assembly through the Lower Support Bracket. Connect to the interior vent system.
 - f) Slide an Outer Joint Gasket over the male end of the Air Intake Section with the tapered edge of the gasket pointing up. Attach the Air Intake Section to the Support Elbow. If necessary, the Air Intake Section can be shortened by cutting the male end as described on page 26. After attaching the Air Intake Section to the Support Elbow, slide the Outer Joint Gasket down over the joint between the two fittings to prevent rain infiltration.
 - g) Attach the Wall bracket to the wall 0"-6" from the bottom edge of the intake bell (Figure 7.34). Use 1/4" screws (not provided) to mount this bracket.
 - h) Slide the remaining Outer Joint Gasket over the male end of the Terminal Elbow. Attach the Terminal Elbow to the Air Intake Section, pointing it away from the wall. Secure the Terminal Elbow to the Air Intake section with a single #10 x 1/2" sheet metal screw (Figure 7.34). Drill a 1/8" hole through both outer pipes to start this screw. **Use a drill stop or other means to ensure that the drill bit does not penetrate more than 3/8" into the outer pipe. Do not use a sheet metal screw longer than 1/2".** Slide the Outer Joint Gasket down over the joint between the Terminal Elbow and the Air Intake Section to prevent rain infiltration.
 - i) Attach the Exhaust Terminal to the Terminal Elbow (Figure 7.34).
- 6) Vertical Terminal Installation - In addition to the vertical terminal, either a Flat Roof Flashing (PN 230533) or Sloped Roof Flashing (PN 230535) is required for this installation.
- a) Determine the center line of the terminal location on the roof. If the roof is flat, cut a 5-1/2" diameter hole for the terminal. If the roof is sloped, cut a hole large enough for the terminal to pass through the roof while remaining plumb. **Caution: If the boiler is installed directly under the hole, cover it while cutting the hole to prevent saw dust and other debris from falling into the boiler.**
 - b) Install the roof flashing using standard practice for the roofing system on the structure.
 - c) If not already done, assemble the venting system inside the building. The last section of pipe needs to be on the same center line as the terminal and within 19-1/4" of the top edge of the roof flashing (Figure 7.35a).
 - d) Measure distance "H" from the top edge of the storm collar to the end of the last fitting as shown in Figure 7.35a.
 - e) Add 1" to distance "H". Carefully mark this length on the pipe as shown in Figure 7.35b.
 - f) Cut the **outer pipe only** at the point marked in Step (e) using aviation shears, a hacksaw, or an abrasive wheel cutter. Be careful to cut the pipe square. De-burr the cut end with a file or emery cloth.
 - g) Place a mark on the aluminum inner pipe 3/8" beyond the end of the outer pipe (Figure 7.35b). Use a fine tooth hacksaw to cut the aluminum pipe and be careful to cut the pipe square. De-burr the cut edge of the aluminum pipe with a file or emery cloth.
 - h) Make a mark on the terminal section 1" from the cut end of the outer pipe as shown in Figure 7.35b.
 - i) Slip the terminal section through the roof from the outside. Push into the last section of vent pipe until the mark made in Step (h) is no longer visible. Secure the terminal to the last piece of pipe with three #10 x 1/2" sheet metal screws. Drill a 1/8" hole through both outer pipes to start these screws. **Use a drill stop or other means to ensure that the drill bit does not penetrate more than 3/8" into the outer pipe. Do not use a sheet metal screw longer than 1/2".**
 - j) Secure the terminal section to the inside of the roof structure using the mounting bracket provided with the terminal (Figure 7.35c).

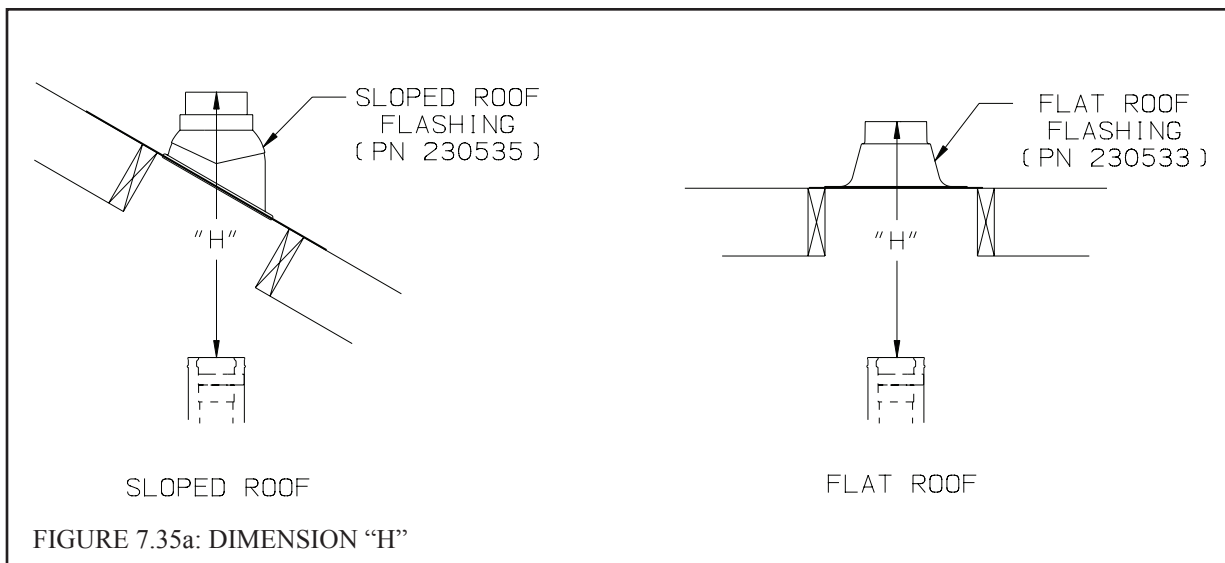

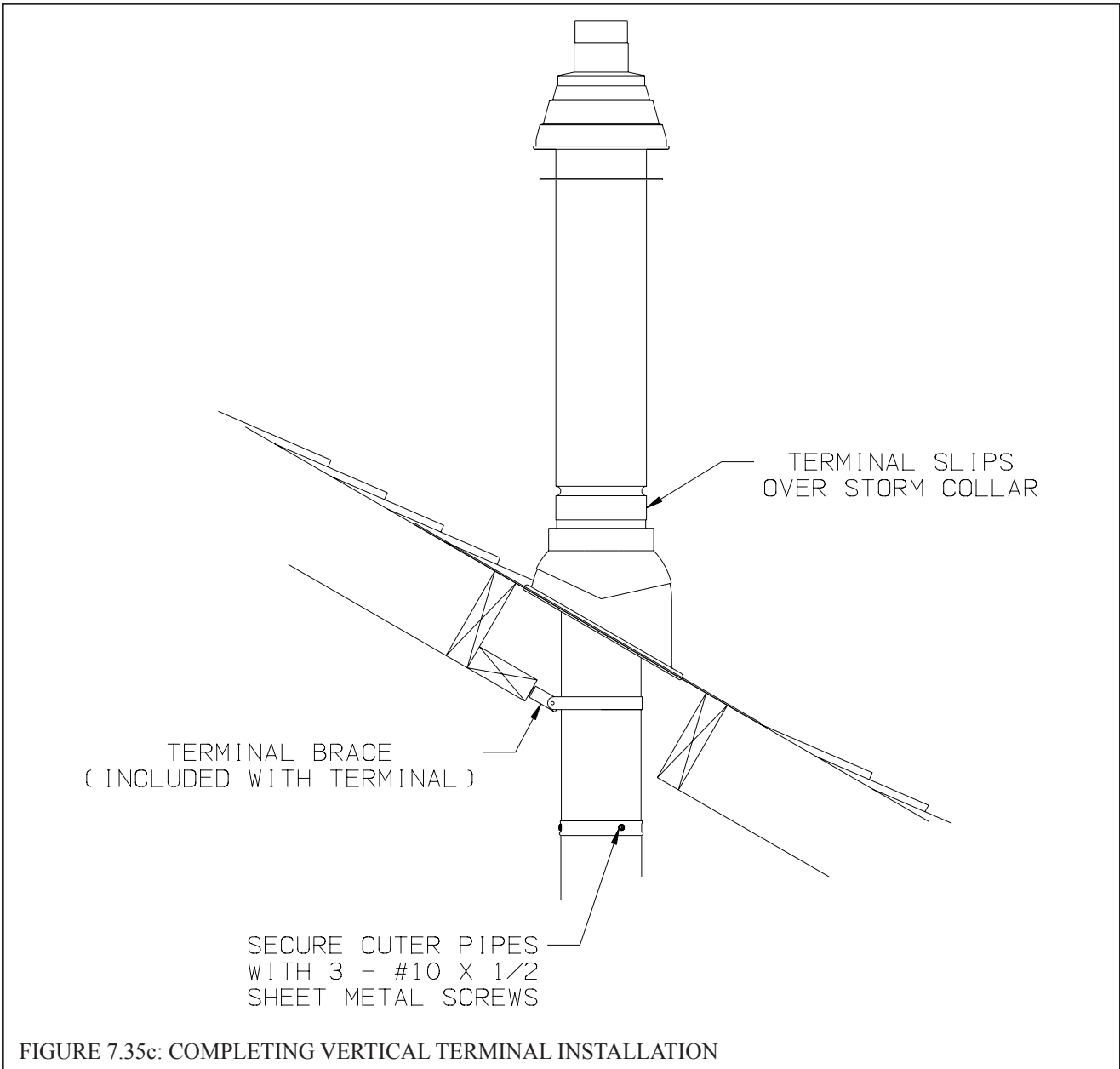
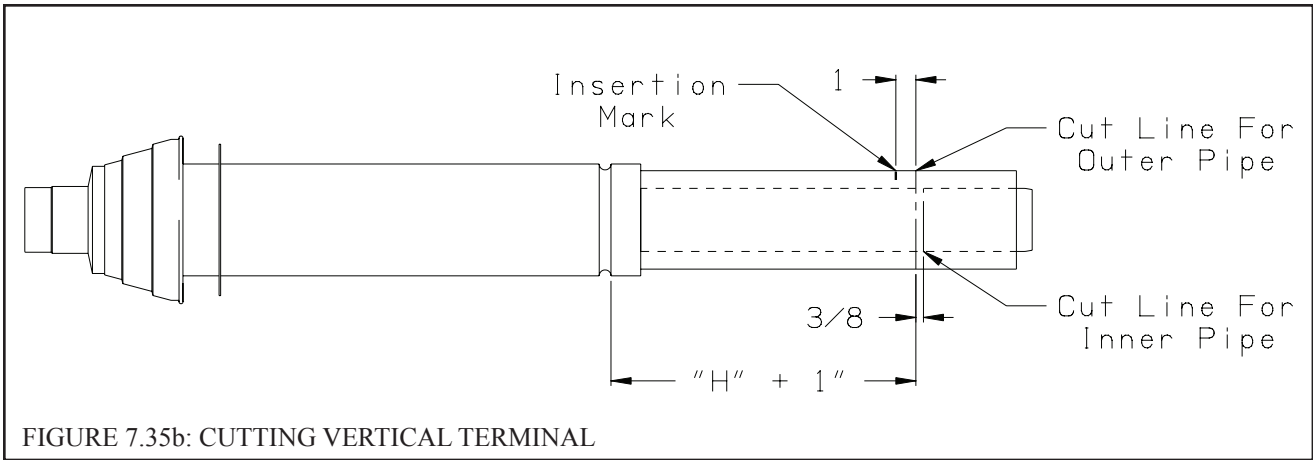

7) Chimney Chase Installation - A vertical 80/125mm vent system can be installed in an unused masonry chimney. This installation is similar to other vertical installations with the following exceptions (Also see Figure 7.36):

- a) The chimney chase elbow kit (PN230530) is used at the base of the chimney. This kit consists of a support elbow and a mounting bracket. Slip the elbow over the M10 x 35 screw in the support bracket. Determine the desired vertical location of the support elbow in the chimney and mark the location of the pin on the back of the support bracket on the back wall of the chimney. Drill a 7/16" dia x 2-1/2" deep hole at this location to support the back of the bracket. The front of the elbow mounting bracket is supported by the bottom of the opening into the chimney or by an installer supplied bracket.
- b) Construct a weather-tight flat roof to cover the top of the old chimney. Install the vertical terminal through this roof using the flat roof flashing.

WARNING

- Do not attempt to construct a vertical vent system inside a chimney that is used to vent a fireplace or other appliances.
- Do not attempt to construct a vertical vent system inside a chimney flue adjacent to another flue used by a fireplace or other appliances.

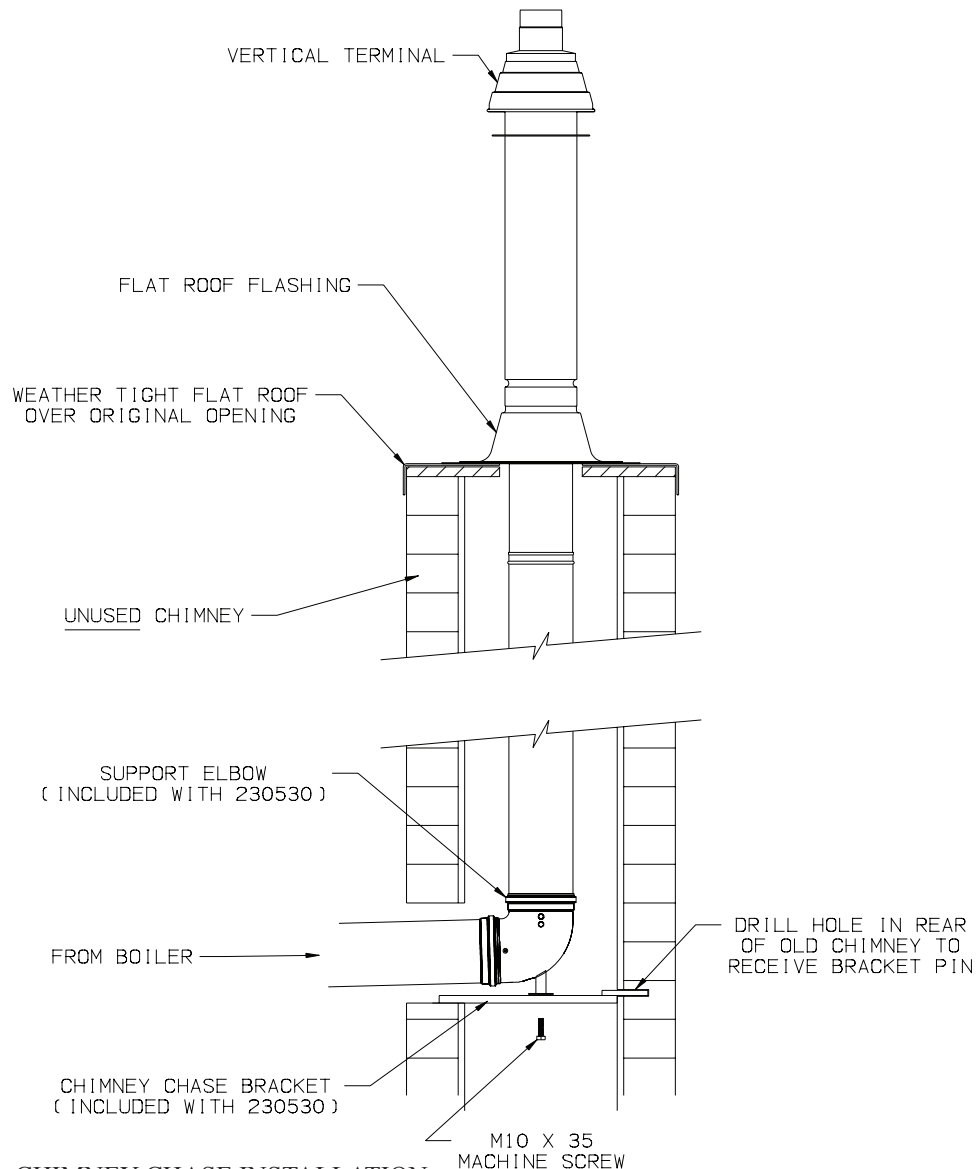

FIGURE 7.36: CHIMNEY CHASE INSTALLATION

E. Assembly of Stainless Steel Venting

CAUTION

Vent systems made by Heat Fab, Protech, Z-Flex, and Metal-Fab rely on gaskets for proper sealing. When these vent systems are used, take the following precautions:

- Make sure that gasket is in position and undamaged in the female end of the pipe.
- Make sure that both the male and female pipes are free of damage prior to assembly.
- Only cut vent pipe as permitted by the vent manufacturer in accordance with their instructions. When pipe is cut, cut end must be square and carefully de burred prior to assembly.

1) General Assembly Notes:

- a) Where the use of “silicone” is called for in the following instructions, use GE RTV 106 for the vent collar. Air inlet piping sections are sealed with any general-purpose silicone sealant such as GE RTV102. PVC air inlet piping sections are connected with PVC cement.
- b) Longitudinal welded seams should not be placed at the bottom of horizontal sections of exhaust pipe.
- c) Do not drill holes in vent pipe.
- d) Do not attempt to mix vent components of different vent system manufacturers.

2) Mounting Stainless steel vent collar -The use of stainless steel venting requires the stainless steel vent collar (Crown PN 230510) which replaces the 80/125mm concentric collar supplied with the boiler. To install the stainless steel vent collar:

- a) Remove the six #10 sheet metal screws which attach the 80/125mm collar to the boiler.
- b) Remove the collar from the boiler (this may be easier if a twisting motion is applied to the collar while removing it).
- c) Lubricate the brown gasket in the female end of the plastic vent stub (inside the boiler) with a few drops of water.
- d) Push the stainless steel vent collar onto the boiler with a slight twisting motion. Make sure that the stainless steel vent adaptor is inserted at least 1” into the boiler stub.
- e) Secure the collar flange to the top of the boiler with the sheet metal screws removed in Step (a)

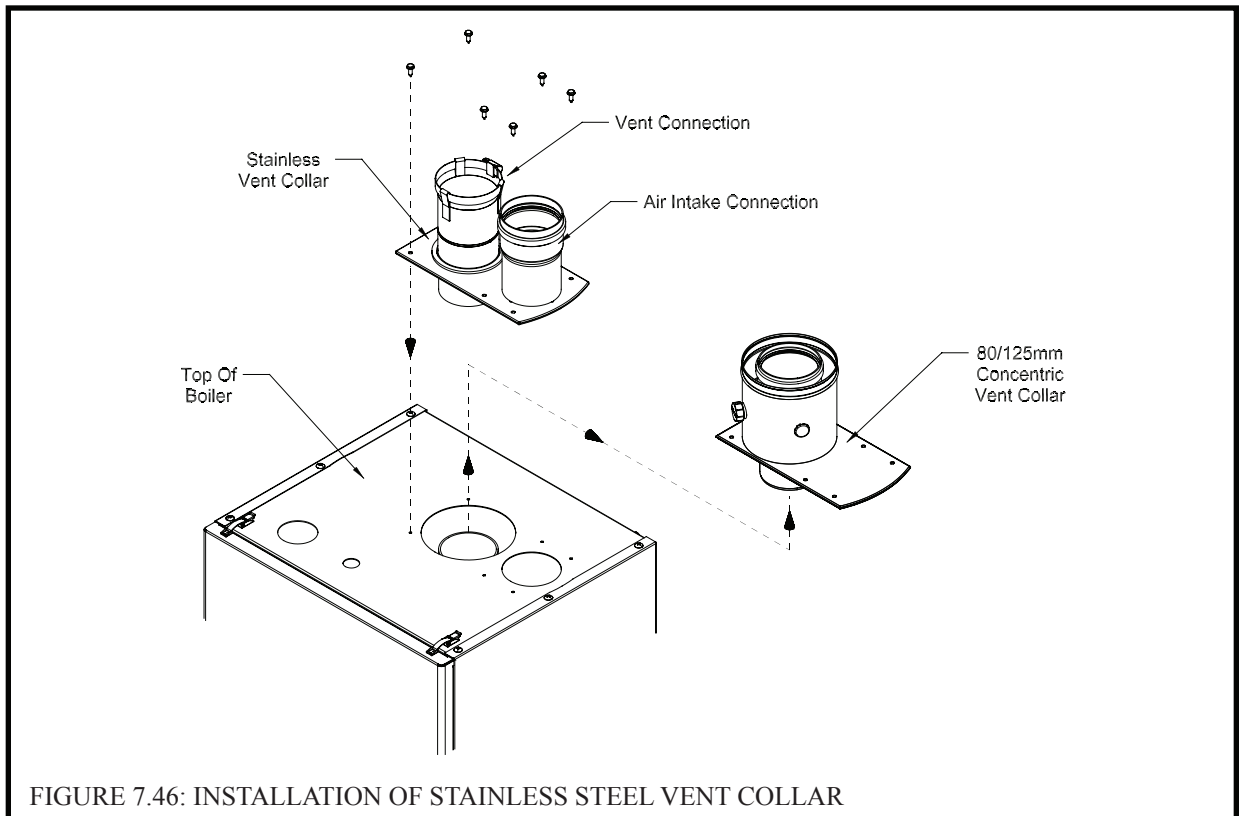

3) Assembly of Metal-Fab Corr/Guard Vent System:

a) Corr/Guard General Notes:

- Do not cut Corr/Guard vent components.
- Refer to Corr/Guard installation instructions for proper methods of support.
- Orient Corr/Guard components so that the males ends of all fittings point in the direction of the boiler.

- b) Start assembly of the vent system at the boiler. Remove the hose clamp shipped on the BWC vent collar. Bend the three hose clamp tabs on this collar outward slightly.
- c) Clean the exterior of the male end of the first piece of pipe and the inside of the vent collar on the boiler. Remove dirt, grease, and moisture from the surfaces to be sealed. Dry surfaces or allow to dry thoroughly.
- d) On the male end of the pipe, apply a 1/4" wide bead of silicone approximately 1/2" from the end of the pipe (Fig 7.47).
- e) Insert the male end of the pipe into the boiler vent collar until it bottoms out.
- f) Apply an additional bead of silicone over the outside of the joint and smooth out.
- g) Replace and tighten the clamp on the vent collar.
- h) Assemble remaining Corr/Guard components in accordance with the Corr/Guard installation instructions.
- i) Allow the silicone to cure per the silicone manufacturer's instructions before operating the boiler.

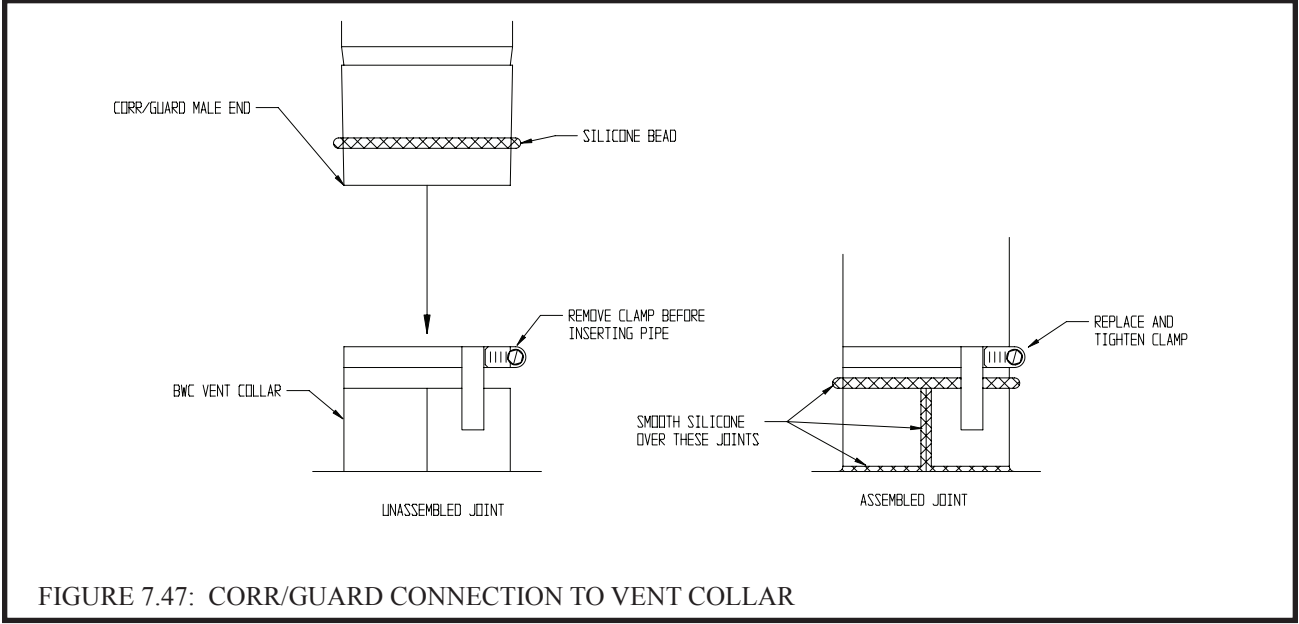
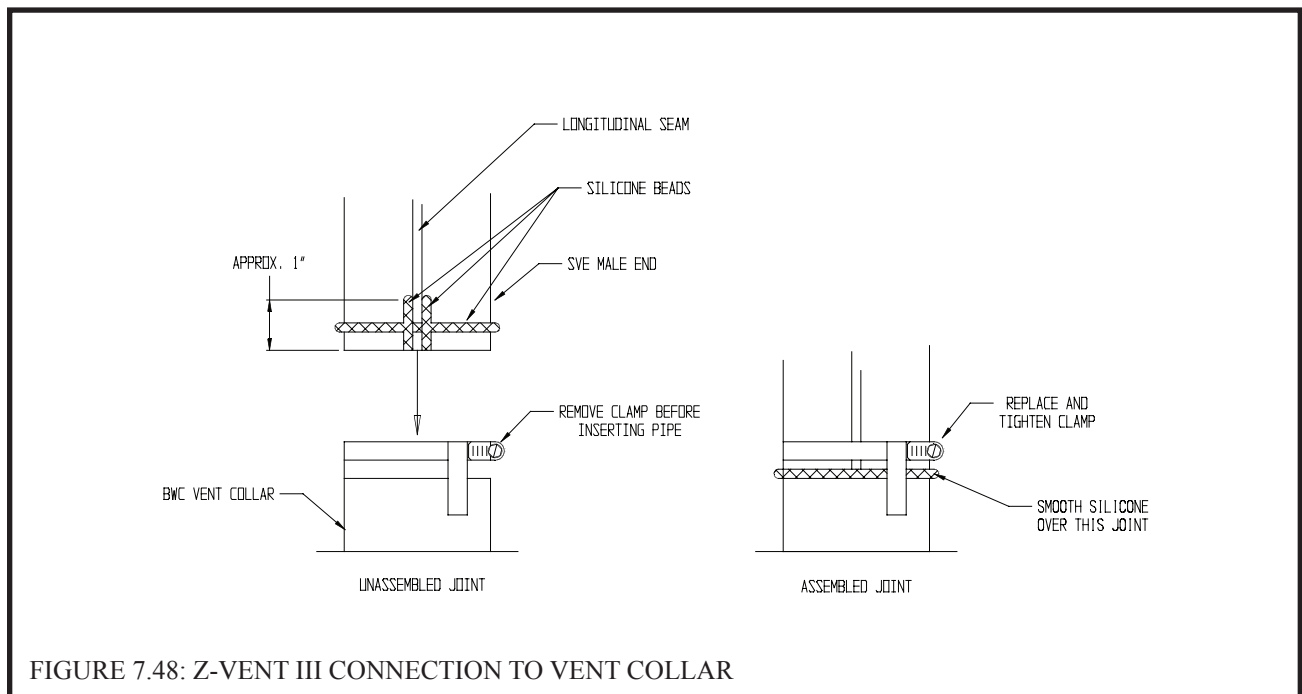

FIGURE 7.47: CORR/GUARD CONNECTION TO VENT COLLAR

4) Assembly of Z-Flex Z-Vent III:

a) General Notes:

- Non-expanded ends of SVE Series III piping sections may be cut using aviation snips or a 24 thread per inch hacksaw. File or sand the cut end smooth before assembling. Expanded ends may be cut to adapt the SVE series III to the vent collar. See the following instructions.
 - Support horizontal piping sections at intervals of 48" or less.
 - Vertical venting systems must be supported by at least one Z-Flex fire stop. An additional vertical support is required after any offset and as required by the Z-Vent III installation instructions.
- b) Start assembly of the vent system at the boiler. Remove the hose clamp shipped on the BWC vent collar. Bend the three hose clamp tabs on this collar outward slightly.
 - c) Clean the exterior of the male end of the first piece of pipe and the inside of the vent collar on the boiler. Remove dirt, grease, and moisture from the surfaces to be sealed. Dry surfaces or allow to dry thoroughly.
 - d) On the male end of the pipe, apply a 1/4" wide bead of high temperature silicone approximately 1/2 inch from the male end of the pipe. Apply 1/4" beads of silicone along both sides of the longitudinal seam (Fig. 7.48).
 - e) Insert the male end of the pipe into the boiler vent collar until it bottoms out.
 - f) Apply an additional bead of silicone over the outside of the joint and smooth out.
 - g) Replace and tighten the clamp on the vent collar.
 - h) The female end of each Z-Vent III component has a silicone sealing gasket. Examine all vent components to insure that the gasket integrity has remained during shipping. Gaskets must be in the proper position or flue gas could leak resulting in carbon monoxide poisoning.
 - i) Align the second piece of pipe with the first and push them together as far as they will go, but not less than 1-3/4".
 - j) Tighten gear clamp to a minimum torque of 40 in-lbs and a maximum of 50 in-lbs.
 - k) Repeat Steps (h) – (j) for the remaining Z-Vent III components.
 - l) In horizontal vent systems, a locking band or gear clamp must be used at either side of the wall penetration to prevent shifting of the vent system in and out of the wall. This applies to both combustible and non-combustible walls.
 - m) Allow the silicone to cure per the silicone manufacturer's instructions before operating the boiler.



5) Assembly of Heat Fab Saf-T Vent EZ Seal:

a) Saf-T Vent General Notes:

- These instructions cover the installation of Saf-T Vent EZ Seal. Saf-T Vent EZ Seal piping has integral gaskets installed in the female ends of the pipe which seal the joints.
- In general, Saf-T Vent pipe sections may not be cut. Exceptions to this are the Saf-T Vent slip connector and connections to the boiler vent collar. In these cases, use a sharp pair of aviation snips, an abrasive cut-off, or a plasma cutter. See the Saf-T Vent instructions for information on cutting the slip connector.
- Orient Saf-T Vent components so that the arrows on the piping labels are in the direction of flue gas flow.
- Support horizontal piping sections at intervals of 6 feet or less.
- Vertical venting systems must be supported by at least one Heat Fab support. An additional vertical support is required after any offset.

b) Connection to Boiler – Start assembly of the vent system at the boiler. Remove the hose clamp shipped on the BWC vent collar. Bend the three hose clamp tabs on this collar outward slightly. Cut the “male spigot” off of the first piece of pipe (Fig 7.49). If necessary, crimp the cut end of the pipe so that it can be inserted at least 1” into the collar. Clean the exterior of the male end of the first piece of pipe and the inside of the vent collar on the boiler with an alcohol pad. On the male end of the pipe, apply a ¼” wide bead of high temperature silicone approximately ½ inch from the male end of the pipe. Also apply a ¼” bead of silicone along the first 2 ½” of the longitudinal weld. Insert the male end of the pipe into the boiler vent collar until it bottoms out. Apply an additional bead of silicone over the outside of the joint and smooth out (Fig 7.49). Replace and tighten the clamp on the vent collar.

c) Assembly of Saf-T Vent EZ Seal Vent Components - Clean the male end of the next piece of pipe with an alcohol pad and make sure that it is free of burrs. Check the female end of the first piece of pipe to make sure that the gasket is in place and is undamaged. Using a slight twisting motion, insert the male end of the second fitting into the female end of the first fitting, taking care not to dislodge or cut the factory gasket. In extremely arid conditions, it may be easier to assemble these fittings if the gasket is moistened with water prior to assembly. Bend the locking tabs over the locking ring on the adjacent piece of pipe. Repeat these steps for the remaining Saf-T-Vent components.

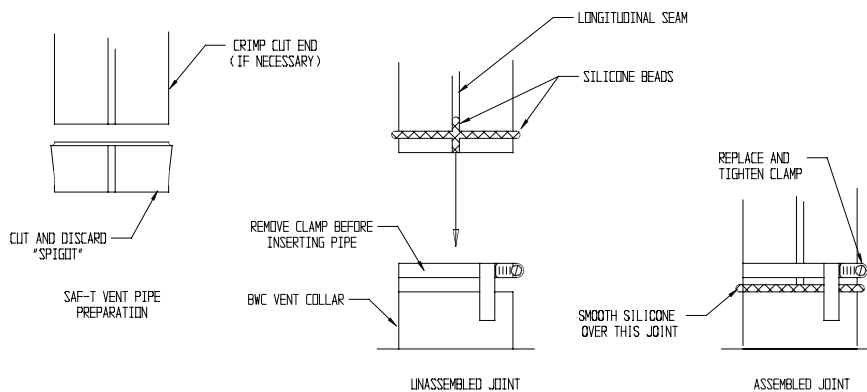

FIGURE 7.49: SAF-T VENT EZ SEAL CONNECTION TO VENT COLLAR

6) Assembly of Protech FasNSeal

a) FasNSeal General Notes:

- Do not cut 4" FasNSeal pipe. Consult FasNSeal instructions for method of cutting other 3" pipe.
- Orient FasNSeal vent components so that the arrows on the piping labels are in the direction of flue gas flow.
- Support horizontal piping sections at intervals of 6 feet or less.
- Vertical venting systems must be supported by at least one FasNSeal support. An additional vertical support is required after any offset.

- b) Remove the hose clamp shipped on the BWC vent collar. Bend the three hose clamp tabs on this collar outward slightly. Clean the exterior of the male end of the first piece of pipe and the inside of the vent collar on the boiler. Remove dirt, grease, and moisture from the surfaces to be sealed. On the male end of the pipe, apply a 1/4" wide bead of high temperature silicone approximately 1/4 inch from the male end of the pipe. Insert the male end of the pipe into the boiler vent collar until it bottoms out. Apply an additional bead of silicone over the outside of the joint and the seams on the vent collar and smooth out (Fig 7.50). Replace and tighten the clamp on the vent collar.
- c) All other joints in the FasNSeal venting system rely on a gasket in the female end of the pipe for a proper seal.
- d) Align the longitudinal seam of both pipes. Insert the male end of the second pipe into the female end of the first pipe until the bead on the male end contacts the flare on the female end.
- e) Tighten the locking band with a nut driver.
- f) Repeat (d) and (e) for the remaining FasNSeal components.
- g) Allow the silicone to cure per the silicone manufacturer's instructions before operating the boiler.

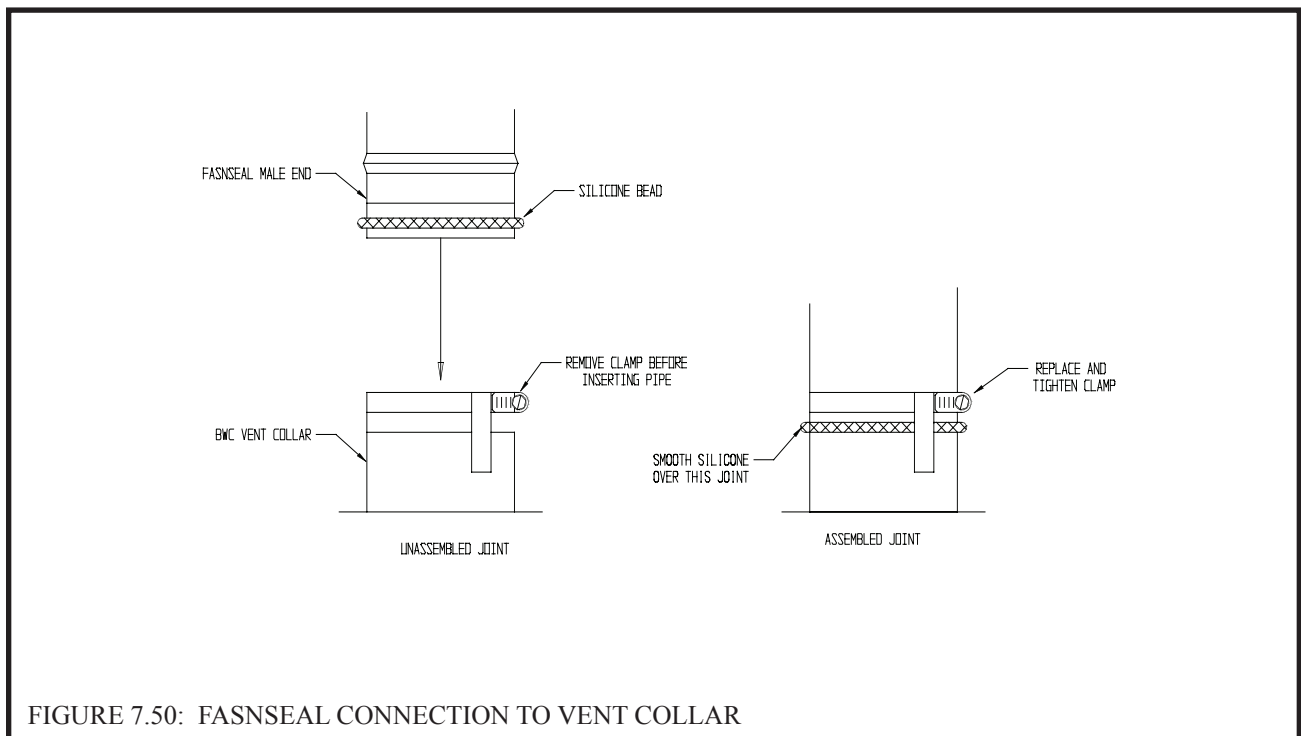

7) Installation of Horizontal Exhaust Terminal:

- a) When stainless steel venting is used, use Crown stainless exhaust terminal #230511. The outer edge of this terminal must be between 6 and 12 inches from the surface of the wall. **The joint between the terminal and the last piece of pipe must be outside of the building.**
- b) Male end of terminal will fit into the female end of any of the approved stainless vent systems.
- c) Apply a heavy bead of silicone to the male end of the terminal before inserting it into the last piece of pipe. Orient the terminal so that the seam in the terminal is at 12:00.
- d) Smooth the silicone over the seam between the terminal and the last piece of pipe, applying additional silicone if necessary to ensure a tight seal.
- e) Allow the silicone to cure per the silicone manufacturer's instructions before operating the boiler.

8) Installation of Vertical Exhaust Terminal - Use the terminal supplied by the vent system manufacturer shown in Table 7.5. Attach to the vent system, following the assembly instructions in this manual for the stainless vent system being used.

9) Assembly of the Air Intake System and Air Intake Terminals:

- a) Assemble the air intake system using either galvanized or PVC pipe.
- b) If PVC piping is used, use PVC cement to assemble the PVC intake system components.
- c) If galvanized piping is used, use at least two sheet metal screws per joint. Seal the outside of all joints.
- d) 3” galvanized smoke pipe will fit inside the inlet collar on the boiler. Depending upon the exact OD of the pipe used, it may be necessary to crimp this pipe. Secure with a single #10 sheet metal screw through the hole in the inlet collar and seal the outside of the joint with silicone. If PVC is used for the intake system, use a short piece of 3” galvanized pipe to connect the PVC to the boiler. Silicone the outside of the joint between the PVC and galvanized pipe.
- e) Horizontal intake terminal is a 90 degree elbow pointing down. Elbow should protrude the same distance from the wall as the exhaust terminal.
- f) Vertical air intake terminal consists of a 180 degree bend (composed of two 90 degree elbows) as shown in Figure 7.10.
- g) Install a rodent screen (not supplied) in the inlet terminal. Use a screen having 1/2” (2 x 2) or larger mesh.

F. Condensate Trap and Drain Line

All condensate which forms in the boiler or vent system collects in the sump under the heat exchanger and leaves the boiler through the condensate trap. This trap allows condensate to drain from the sump while retaining flue gases in the boiler. The trap is supplied loose and must be installed as shown in Figure 7.51. A length of drain hose is supplied with the boiler and is connected to the trap as shown in Figure 7.51. Note the following when disposing of the condensate:

- a) If the condensate drain line must be extended, construct the extension from PVC or CPVC pipe. Insert the hose provided with the boiler into the end of the extension as shown in Figure 7.51.
- b) Condensate is slightly acidic. Do not use metallic pipe or fittings in the condensate drain line. Do not route the drain line through areas that could be damaged by leaking condensate.
- c) Some jurisdictions may require that the condensate be neutralized before disposal. Dispose of condensate in accordance with local codes.
- d) Do not route, or terminate, the condensate drain line in areas subjected to freezing temperatures.
- e) If the point of condensate disposal is above the trap, it will be necessary to use a condensate pump to move the condensate to the drain. In such cases, select a condensate pump that is approved for use with condensing furnaces. If overflow from this pump would result in property damage, select a pump with an overflow switch and use this switch to shut down the boiler. Alternatively, if heat is a necessity, use the overflow switch to trigger an alarm.
- f) Do not attempt to move the trap from the location shown in Figure 7.51. Do not attempt to substitute another trap for the one provided with the boiler.
- g) The vent shown in Figure 7.51 must be left open for the trap to work properly.

WARNING

FAILURE TO INSTALL THE CONDENSATE TRAP AND CONDENSATE DRAIN IN ACCORDANCE WITH THE ABOVE INSTRUCTIONS COULD CAUSE FLUE GAS TO ENTER THE BUILDING, RESULTING IN PERSONAL INJURY OR DEATH.

CAUTION

BOILER CONDENSATE IS CORROSIVE. ROUTE CONDENSATE DRAIN LINE IN A MANNER SUCH THAT ANY CONDENSATE LEAKAGE WILL NOT CAUSE PROPERTY DAMAGE.

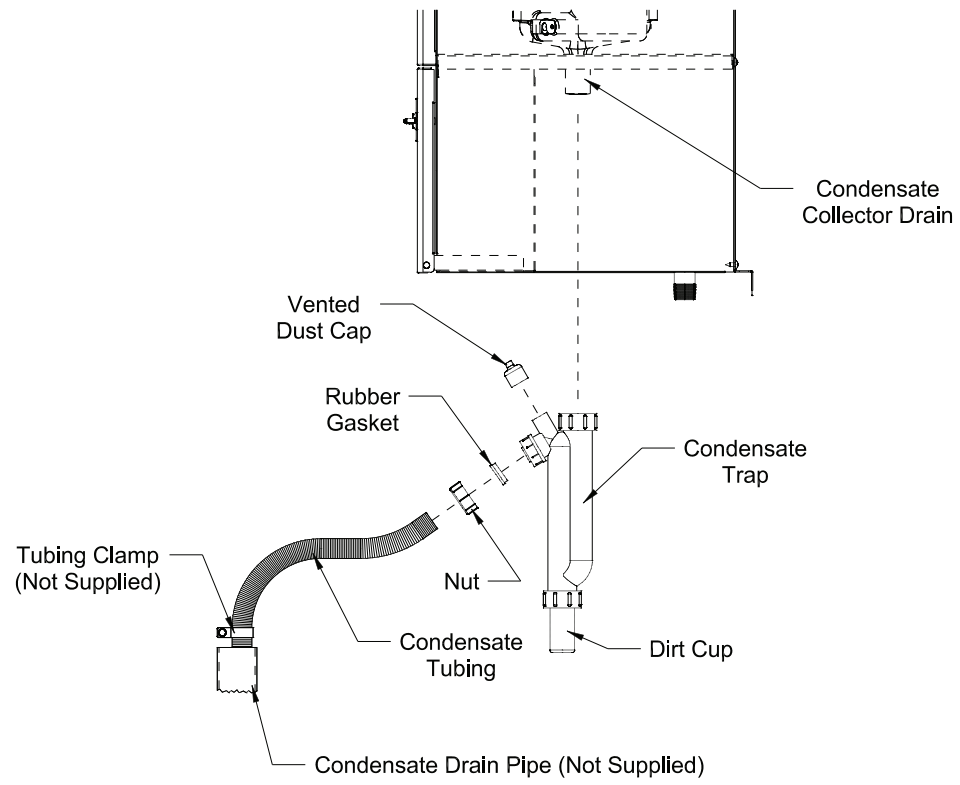

FIGURE 7.51: CONDENSATE PIPING ARRANGEMENT

VIII Gas Piping

Gas piping to the boiler must be sized to deliver adequate gas for the boiler to fire at the nameplate input at an inlet pressure between the minimum and maximum values shown on the rating plate. For more information on gas line sizing, consult the utility or the National Fuel Gas Code.

Figure 8.1 shows typical gas piping connection to the BWC boiler. A sediment trap must be installed upstream of all gas controls. Install the factory provided manual shut-off valve outside the jacket with a ground joint union as shown.

The boiler and its gas connection must be leak tested before placing the boiler in operation. When doing this, the boiler and its individual shut-off must be disconnected from the rest of the system during any pressure testing of that system at pressures in excess of 1/2 psi (3.5kPa). When pressure testing the gas system at pressures of 1/2 psi (3.5kPa) or less, isolate the boiler from the gas supply system by closing its individual manual shut-off valve.

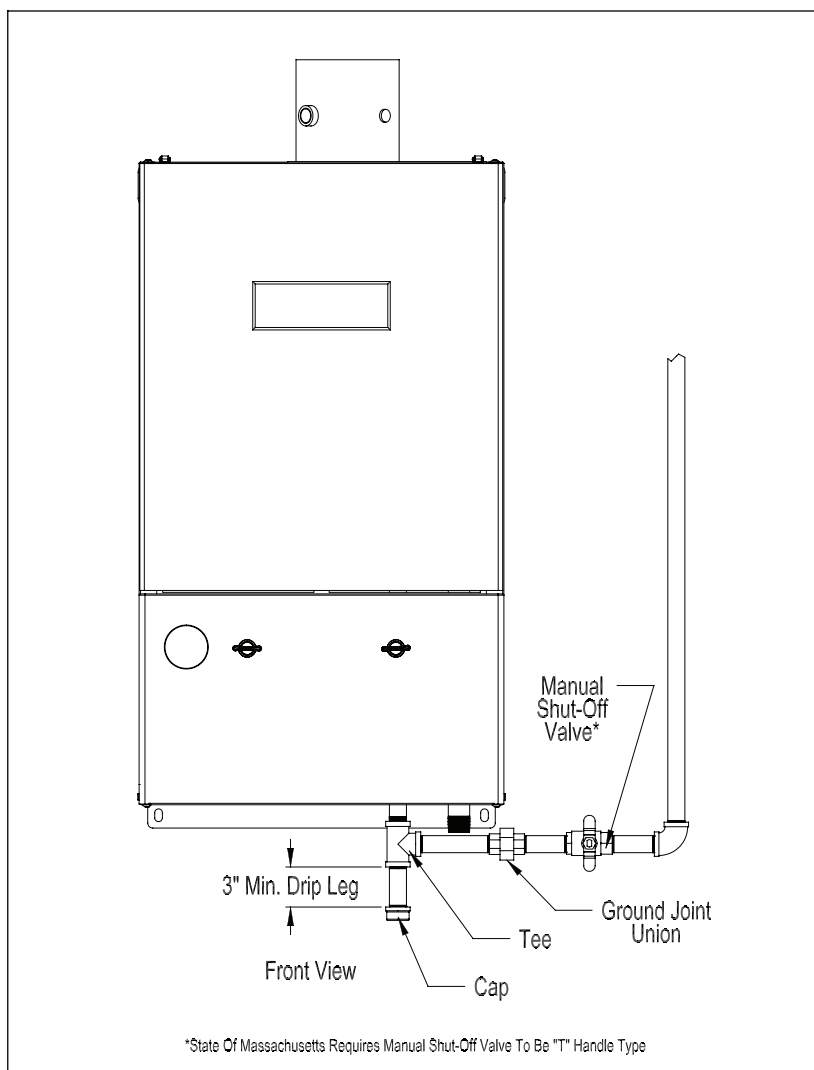

Figure 8.1: Gas Connection To Boiler

IX System Piping

A. General System Piping Precautions

WARNING

INSTALL BOILER SO THAT THE GAS IGNITION SYSTEM COMPONENTS ARE PROTECTED FROM WATER (DRIPPING, SPRAYING, RAIN, ETC) DURING APPLIANCE OPERATION AND SERVICE (CIRCULATOR REPLACEMENT, ETC).

CAUTION

THE HEAT EXCHANGER USED IN THE BWC IS MADE FROM A SPECIAL ALUMINUM ALLOY. FAILURE TO TAKE THE FOLLOWING PRECAUTIONS COULD RESULT IN SEVERE BOILER DAMAGE.

- BEFORE CONNECTING BOILER, MAKE SURE THAT THE SYSTEM IS FREE OF SEDIMENT, FLUX AND ANY RESIDUAL BOILER WATER ADDITIVES. FLUSH THE SYSTEM IF NECESSARY TO ENSURE THAT THESE CONTAMINATES ARE REMOVED.
- DO NOT CONNECT THIS BOILER TO A SYSTEM THAT IS SUBJECT TO REGULAR ADDITIONS OF MAKEUP WATER OR ONE WHICH EMPLOYS RADIANT TUBING WITHOUT AN OXYGEN BARRIER.
- DO NOT ADD ANTIFREEZE OR OTHER BOILER WATER TREATMENT CHEMICALS EXCEPT THOSE LISTED IN PART XI OF THIS MANUAL.
- MAINTAIN THE PRESSURE IN THE BOILER AT A MINIMUM OF 12 PSI.
- DESIGN SYSTEM TO ENSURE THAT THE FLOW FALLS WITHIN THE LIMITS CALLED FOR IN TABLE 9.1.

B. System Design

Proper operation of the BWC boiler requires that the water flow through the boiler remain within the limits shown in Table 9.1 any time the burner is firing. Failure to maintain the flow within these limits could result in erratic operation or premature boiler failure.

There are two basic methods that can be used to pipe the BWC boiler. Method #1 is almost always preferred. The instructions on the following pages describe these methods for piping BWC boilers and explain how to size the circulator and piping. Additional information on hydronic system design may be found in Installation of Residential Hydronic Systems (Pub. #200) published by the Hydronics Institute in Berkeley Heights, NJ.

TABLE 9.1: FLOW REQUIREMENTS THROUGH BOILER

BOILER MODEL	MIN. REQUIRED FLOW (GPM)	MAX. ALLOWABLE FLOW (GPM)
BWC070	4.0	9.0
BWC090	4.0	9.0
BWC120	4.5	12.0
BWC151	6.0	15.0

Method 1: Primary/Secondary Piping

This method can be used in heat-only applications as shown in Figure 9.2 or with an indirect water heater as shown in Figure 9.3. This method relies on primary/secondary pumping to ensure that the required flow is always maintained through the boiler. In this system, the flow rate through the boiler is completely independent of the flow rate through the heating system. Use the following guidelines to ensure that the boiler will have the required flow shown in Table 9.1 regardless of the flow in the heating system.

- 1) Primary Loop Piping - Size the primary circulator and piping to obtain the design flow rate through the heating system as you would on any other heating system. All piping between the expansion tank and secondary connection tees must be at least as large as that shown in Table 9.5, column (a). In order to keep the flow rates in the primary and secondary loops independent of each other, provide at least 8 diameters of straight pipe upstream of the first secondary tee and 4 diameters downstream of the second secondary tee. Keep the distance between the expansion tank and the first secondary tee as short as practical.
- 2) Secondary Loop (“Boiler Loop”) Piping – All piping must be the size shown for the boiler in Table 9.5, column (a). To size the circulator:
 - a) Select one of the boiler water flow rates shown in Table 9.5, column (b) for the boiler being installed. When selecting the required boiler flow rate, keep in mind that if the flow rate in the primary loop exceeds the flow rate through the boiler, it will not be possible to obtain a 180°F supply temperature in the primary loop. This is because the supply water exiting the boiler will be mixed with cooler system return water before entering the radiation.
 - b) Count all fittings in the planned secondary loop (the secondary loop consists of the shaded piping in Figure 9.4a). In doing so, do not count the secondary connection tees, unions, or the fittings supplied with the boiler (these have already been accounted for).
 - c) Using Table 9.7, find the equivalent lengths of all fittings in the secondary loop. Total these equivalent lengths and add them to the total length of planned straight pipe in the secondary loop. The result is the total equivalent length of the secondary loop.
 - d) Using Table 9.5, find the boiler size being installed and select a boiler secondary circulator that shows a “maximum equivalent length” (column e) in excess of the total equivalent length calculated in Step (c).
- 3) Indirect Water Heater Loop Piping (If Indirect Water Heater is Used) – All piping must be the size shown in Table 9.6, column (a). If the indirect water heater connections are smaller than the pipe size called for in column (a), reduce the pipe size at the indirect water heater connections. To size the circulator:
 - a) Count all fittings in the planned Indirect Water Heater Loop (the indirect water heater loop consists of the shaded piping in Figure 9.4b). In doing so, you will be counting some piping and fittings which are common to the heating system secondary (“boiler loop”) piping and which were counted in Step 2a above. Do not count the elbows or fittings supplied with the boiler.
 - b) Using Table 9.7, find the equivalent lengths of all fittings in the indirect water heater loop. Total these equivalent lengths and add them to the total length of planned straight pipe in the indirect water heater loop. The result is the total equivalent length of the indirect water heater loop.
 - c) Using Table 9.6, find the boiler size being installed and select an indirect water heater loop circulator (“DHW circulator”) that shows a “maximum equivalent length” (column f) in excess of the total equivalent length calculated in Step b.

Example – Assume that a BWC120 is to be installed in a heating system along with a Crown MS-40 indirect water heater. A total of 15 ft of straight pipe will be installed between the boiler and the primary loop. A total of 20 ft of straight pipe will be installed between the boiler and the indirect water heater. Fittings are arranged as shown in Figure 9.3. A 9.0 GPM flow is required in the boiler loop. The MS-40 requires a flow rate of 8 GPM and has a head loss of 3.0 ft.

Total fittings in Secondary loop (“boiler loop”):

*6 90 Elbows
2 Runs of Tees
1 Swing Check
2 Isolation Valves*

Note: Unions, Secondary Connection Tees, and factory supplied fittings are ignored.

Calculate total equivalent length from Table 9.7:

15ft Straight Pipe + 6 Elbows x 2.75 + 2 Runs of Tees x 1.75 + 1 Swing Check x 7 + 2 valves x 0.6 = 43.2 equivalent feet straight pipe. From Table 9.5, we see that a Taco 0014 will pump 9 GPM through a BWC120 with 61 equivalent feet of pipe, so the Taco 0014 is OK.

Example (contd.)

Total fittings in Indirect Water Heater Loop:

- 5 90 Elbows
- 2 Turns in Tees
- 1 Swing Check
- 2 Isolation Valves

Calculate total equivalent length from Table 9.7:

$20 \text{ Straight Pipe} + 5 \text{ Elbows} \times 2.75 + 2 \text{ Turns in Tees} \times 5.5 + 1 \text{ Swing Check} \times 7 + 2 \text{ valves} \times 0.6 = 52.95$
Equivalent Feet Straight Pipe. From Table 9.6, we see that smallest circulator which will pump at 8 GPM through a BWC120 with 52.95 equivalent feet and an indirect water heater pressure drop of 3 ft is a Taco 0014.

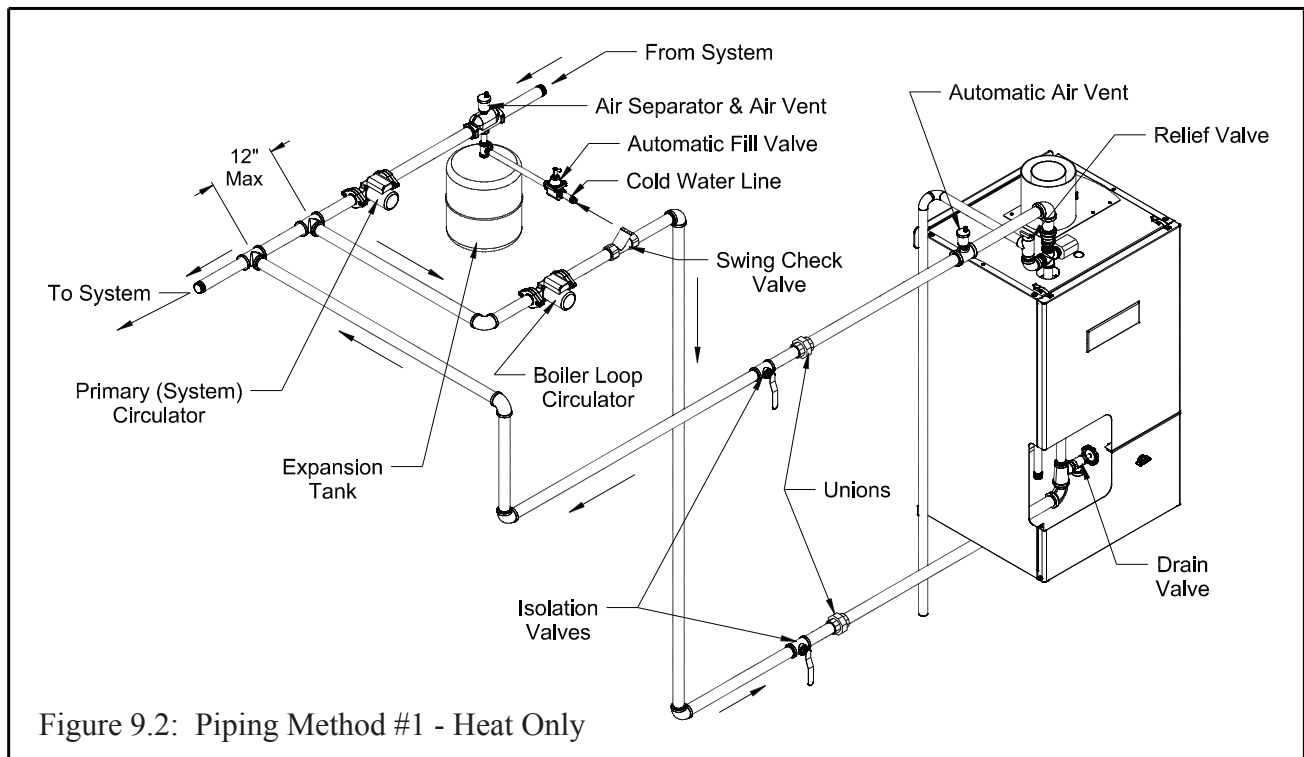

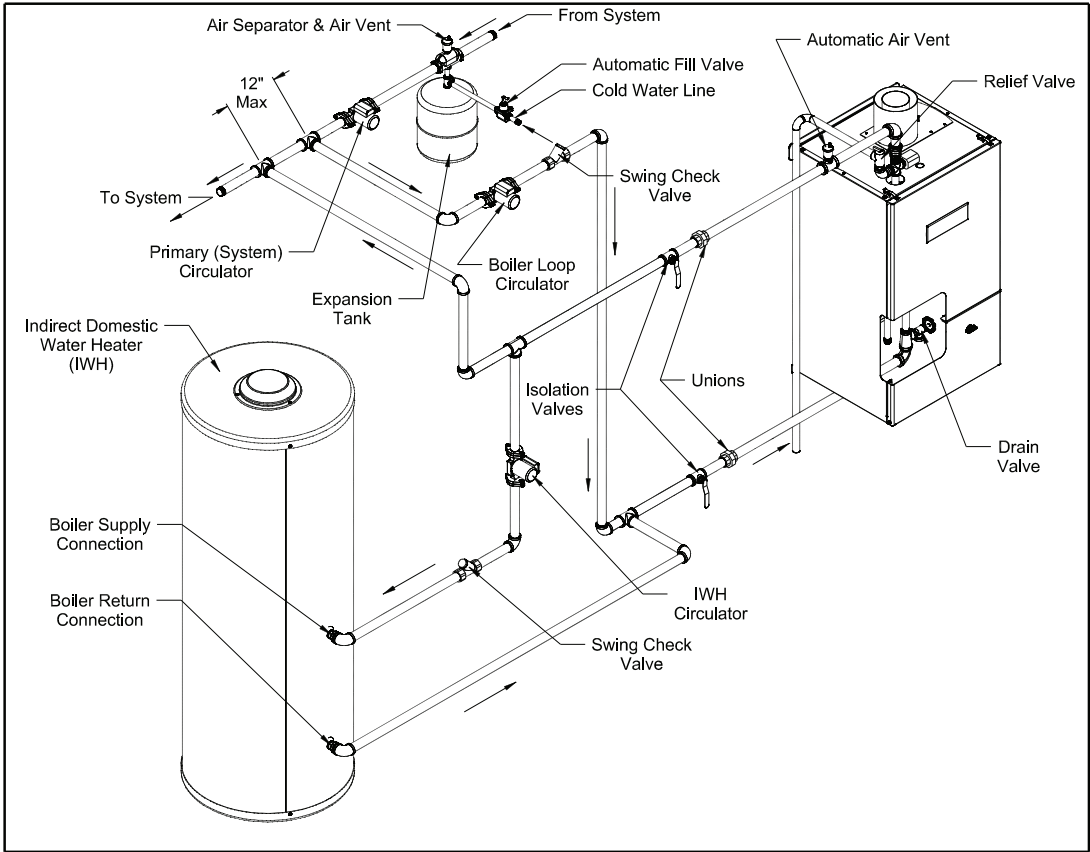

Figure 9.3: Piping Method #1 - Heat + Indirect Water Heater

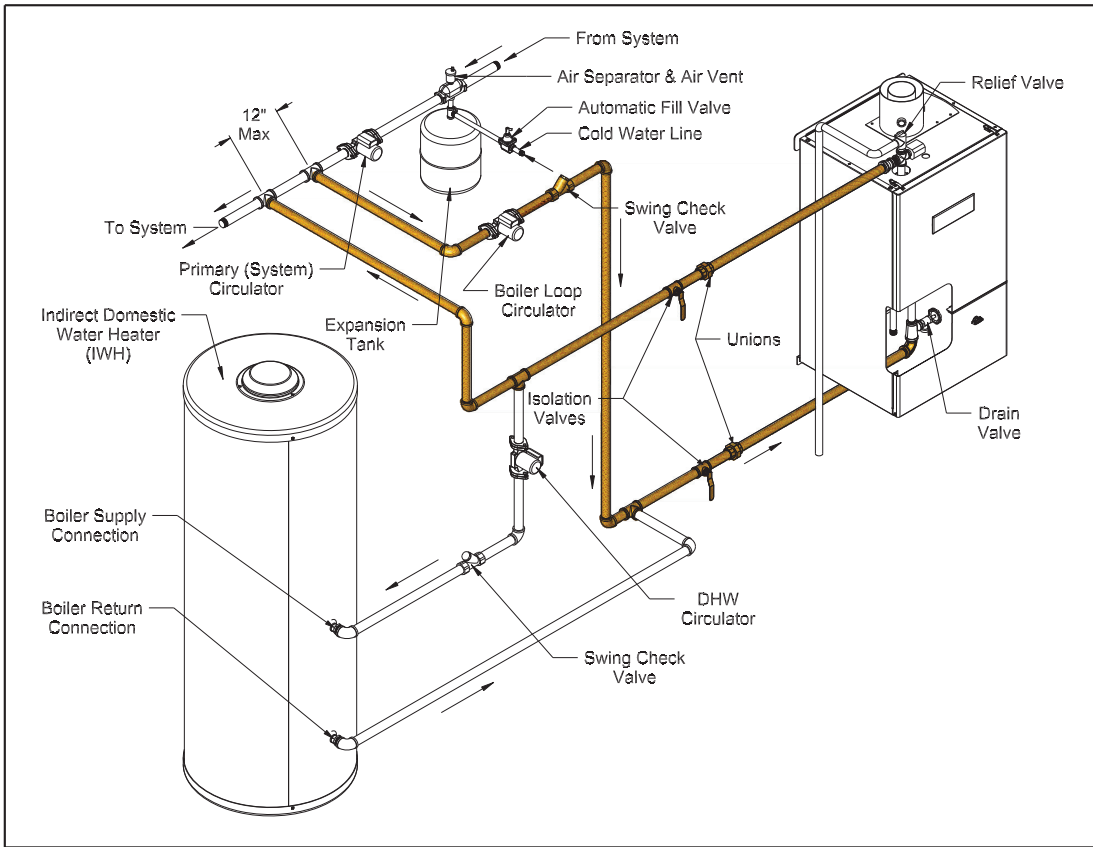

Figure 9.4a: Piping Method #1 - Secondary Loop Piping (Shaded)

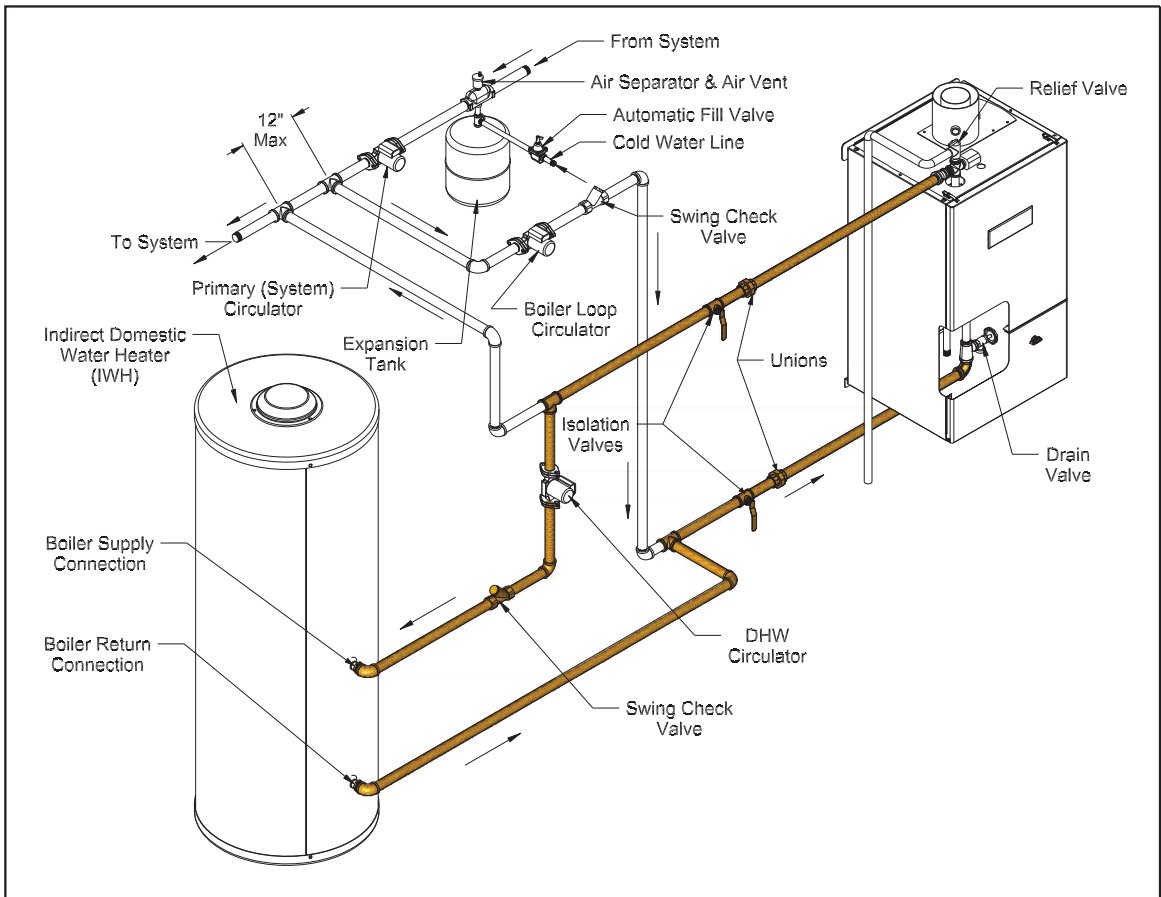

Figure 9.4b: Piping Method #1 - Indirect Water Heater Loop Piping (Shaded)

TABLE 9.5: PIPE AND CIRCULATOR SIZING FOR BOILER LOOP

BOILER MODEL	(a) PIPE SIZE (in NPT)	(b) FLOW (GPM)	(c) TEMP RISE (F)	(d) CIRCULATOR MODEL	(e) BOILER LOOP MAX EQUIVALENT LENGTH (ft)
BWC070	1	6.0	21	Taco 007	67
BWC070	1	6.0	21	Taco 008	171
BWC090	1	8.0	21	Taco 0014	135
BWC120	1	8.0	29	Taco 0014	166
BWC120	1	9.0	25	Taco 0014	95
BWC120	1	12.0	19	Taco 0013 (Note #1)	51
BWC151	1	8.0	34	Taco 008	106
BWC151	1	11.0	25	Taco 0014	68
BWC151	1	14.0	19	Taco 0013 (Note #1)	59

NOTE: 1) Use isolation relay between Taco 0013 and BWC - see Figure 10.3

TABLE 9.6: PIPE AND CIRCULATOR SIZING FOR INDIRECT WATER HEATER LOOP

BOILER MODEL	(a) PIPE SIZE (in NPT)	(b) FLOW (GPM)	(c) MAX. I.W.H. PRESSURE DROP (ft HEAD)	(d) CROWN INDI- RECT WATER HEATERS	(e) DHW CIRCULATOR MODEL	(f) I.W.H. LOOP MAX EQUIVALENT LENGTH (ft)
BWC070	1	6.0	1.7	MS-26 (*) MS-40 (*) MSH-40H (*) MT040GBR (*)	Taco 008	122
BWC090	1	8.0	3.0	MS-26 MS-40 (*) MSH-40H MT040GBR (*)	Taco 0014	78
BWC120	1	8.0	3.0	MS-26 MS-40 MSH-40H MT040GBR MT050GBR MT065GBR MT080GBR	Taco 0014	108
BWC120	1	8.0	5.0	MSH-53H	Taco 0014	70
BWC151	1	8.0	3.0	MS-26 MS-40 MSH-40H MT040GBR MT050GBR MT065GBR MT080GBR	Taco 008	49
BWC151	1	8.0	5.0	MS-53 MS-53H MSH-79(*)	Taco 0014	150

TABLE 9.6 NOTES:

1) Indirect water heaters with an asterisk (*) will not achieve their catalog rating due to inadequate boiler water flow and/or inadequate boiler output.

TABLE 9.7: FITTING EQUIVALENT LENGTHS

FITTING	PIPE SIZE	EQUIVALENT LENGTH (ft)
90 ELBOW	1	2.75
TURN IN TEE	1	5.50
RUN OF TEE	1	1.75
SWING CHECK	1	7.00
GATE VALVE	1	0.60

Method 2: Direct Connection to Heating System (Generally NOT Recommended)

The BWC can be connected directly to the heating system as is done with conventional boilers (Figure 9.8). If this is done, the flow rate through the boiler will equal the flow rate through the system. The flow rate through the system must therefore always remain within the limits shown in Table 9.1. For this reason, the pressure drop through the entire system must be known, added to the boiler pressure drop, and a circulator selected which will provide the required flow at the total calculated pressure drop.

This method is generally not recommended because it is often very difficult to accurately calculate the pressure drop through the system. In replacement installations, it may be impossible to get an accurate measurement of the amount of piping and number of fittings in the system. In addition, if the system is zoned, the system flow may drop well below the minimum required when only one zone is calling for heat.

The one advantage to this method is its installation simplicity. It may make sense to use this method when the boiler is to be installed with a new single zone system having a low-pressure drop. Pressure drop curves for the BWC Series boilers are shown in Figure 9.9. Calculation of the system pressure drop, and selection of the circulator, must be performed by someone having familiarity with pressure drop calculations, such as an HVAC engineer.

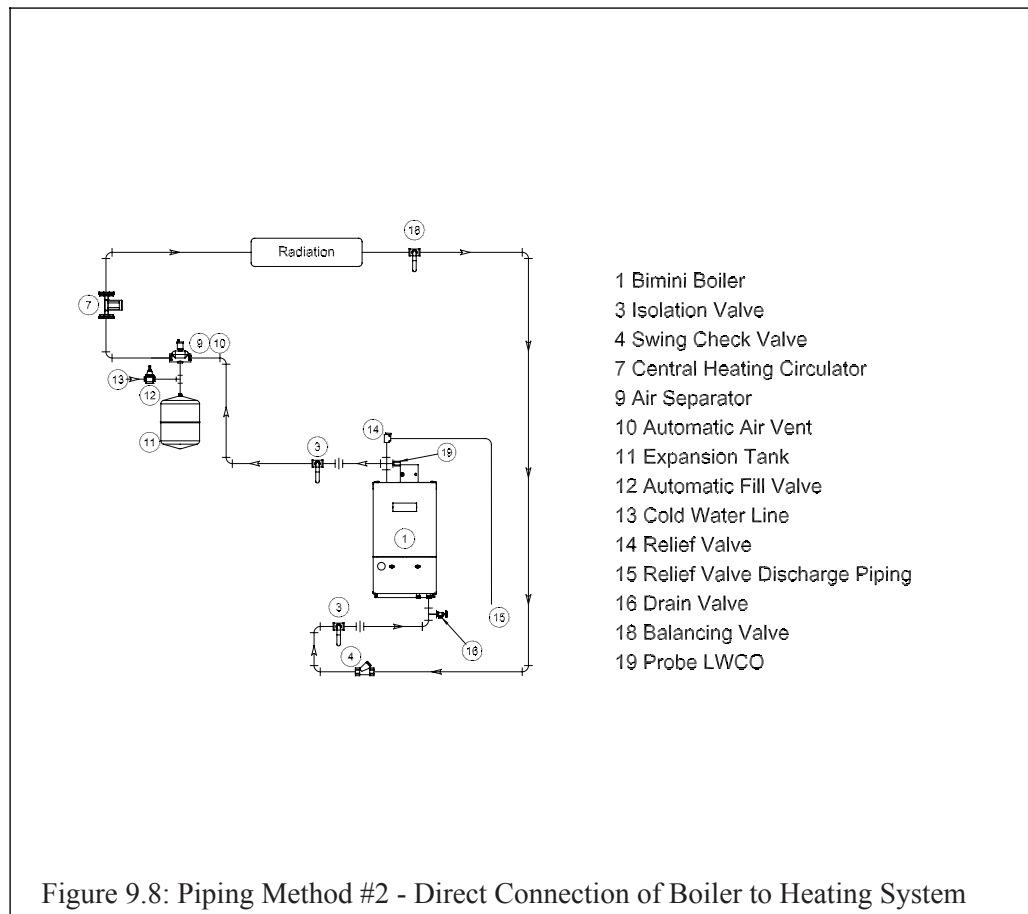

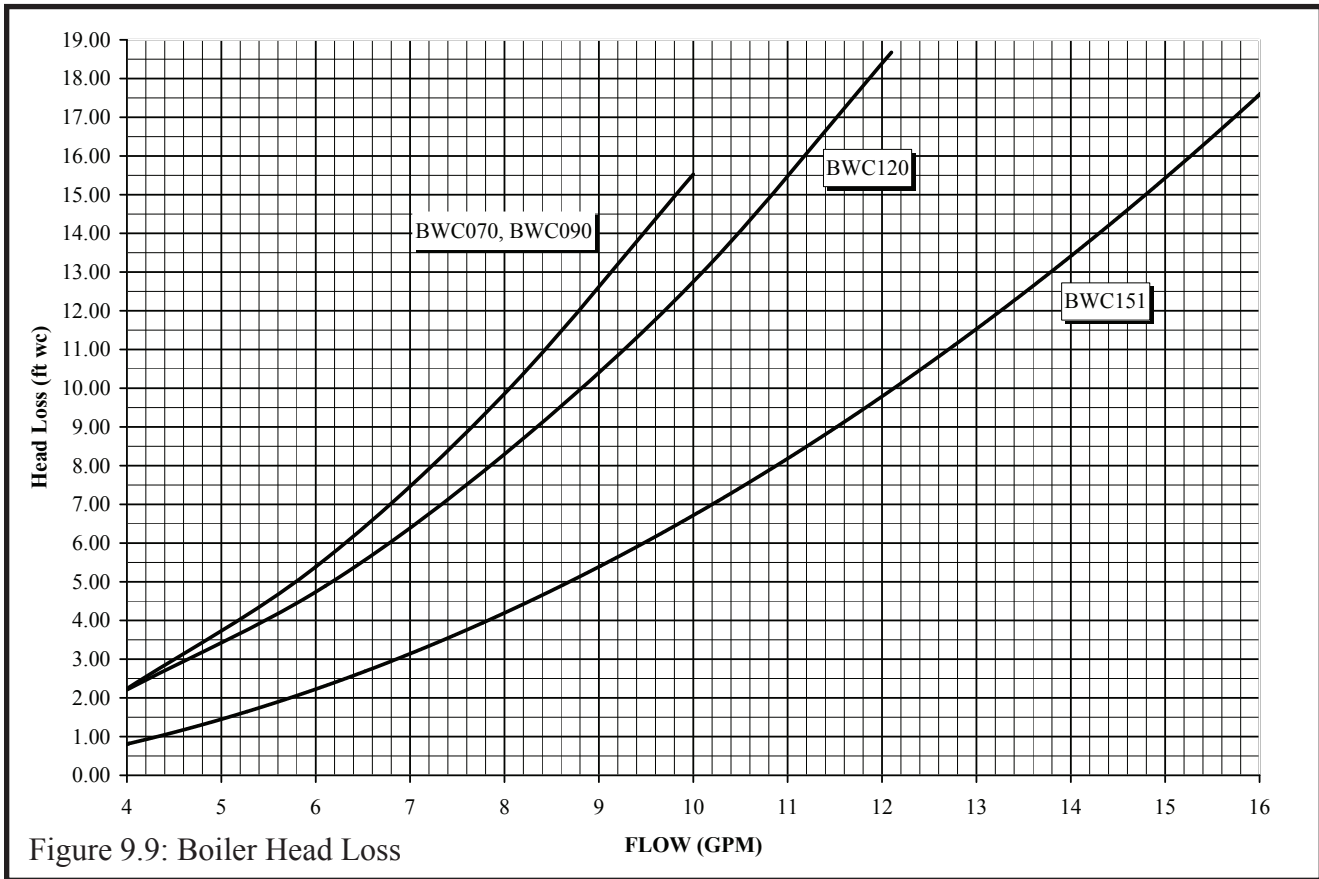

C: Standard Piping Installation Requirements

Observe the following guidelines when making the actual installation of the boiler piping:

- 1) The relief valve is packaged loose with the boiler and must be installed in the location shown in Figure 2.1. The relief valve is set to open at 30 psi. If the valve is replaced, the replacement must have a relief capacity in excess of the DOE heating capacity for the boiler. Pipe the discharge of the relief valve to a location where water or steam will not create a hazard or cause property damage if the valve opens. The end of the discharge pipe must terminate in an unthreaded pipe. If the relief valve discharge is not piped to a drain, it must terminate at least 6 inches above the floor. Do not run relief valve discharge piping through an area that is prone to freezing. The termination of the relief valve discharge piping must be in an area where it is not likely to become plugged by debris.

DANGER

- PIPE RELIEF VALVE DISCHARGE TO A SAFE LOCATION.
- DO NOT INSTALL A VALVE IN THE RELIEF VALVE DISCHARGE LINE.
- DO NOT INSTALL RELIEF VALVE IN A LOCATION OTHER THAN THAT SPECIFIED BY THE FACTORY.
- DO NOT PLUG THE RELIEF VALVE DISCHARGE.

- 2) Circulator (Required) - Usually at least two circulators will be required to properly install a BWC Series boiler. See the previous section for information on sizing the circulators.
- 3) Expansion Tank (Required) - If this boiler is replacing an existing boiler with no other changes in the system, the old expansion tank can generally be reused. If the expansion tank must be replaced, consult the expansion tank manufacturer's literature for proper sizing.
- 4) Fill Valve (Required) - Either a manual or automatic fill valve may be used. The ideal location for the fill is at the expansion tank.
- 5) Automatic Air Vent (Required) - At least one automatic air vent is required. Manual vents will usually be required in other parts of the system to remove air during initial fill.

IMPORTANT

If there are any downturns, or downward pitches, in the boiler supply piping between the boiler and the automatic air vent mounted on the system's air separator, install a second automatic air vent in the supply piping as close as possible to the boiler (Figures 9.2-9.4). This will prevent nuisance low water cut-off lockouts due to trapped air.

- 6) Manual Reset High Limit (Required by some codes) - This control is required by ASME CSD-1 and some other codes. Install the high limit in the boiler supply piping just above the boiler with no intervening valves. Set the manual reset high limit to 200°F. Wire the limit per Figures 10.1 & 10.2 in the Wiring section.
- 7) Flow Control Valve (Required) - The flow control valve prevents flow through the system unless the circulator is operating. Flow control valves are used to prevent gravity circulation or "ghost flows" in circulator zone systems through zones that are not calling for heat.
- 8) Isolation Valves (Recommended) - Isolation valves are useful when the boiler must be drained, as they will eliminate having to drain and refill the entire system.
- 9) Drain Valve (Required) - The drain valve is installed on the return tee located in the lower vestibule compartment as shown in Figure 9.2.
- 10) Low Water Cut-off (Required) - The low water cut-off supplied with this boiler must not be removed.

D. Piping for Special Situations

- 1) Systems containing oxygen - Many hydronic systems contain enough dissolved oxygen to cause severe corrosion damage to an aluminum boiler such as the BWC. Some examples include:
 - Radiant systems that employ tubing without an oxygen barrier.
 - Systems with routine additions of fresh water.
 - Systems which are open to the atmosphere.

If the boiler is to be used in such a system, it must be separated from the oxygenated water being heated with a heat exchanger as shown in Figure 9.10. Consult the heat exchanger manufacturer for proper heat exchanger sizing as well as flow and temperature requirements. All components on the oxygenated side of the heat exchanger, such as the pump and expansion tank, must be designed for use in oxygenated water.
- 2) Piping with a Chiller - If the boiler is used in conjunction with a chiller, pipe the boiler and chiller in parallel as shown in Figure 9.11. Use isolation valves to prevent chilled water from entering the boiler.
- 3) Air Handlers - Where the boiler is connected to air handlers through which refrigerated air passes, use flow control valves in the boiler piping or other automatic means to prevent gravity circulation during the cooling cycle.

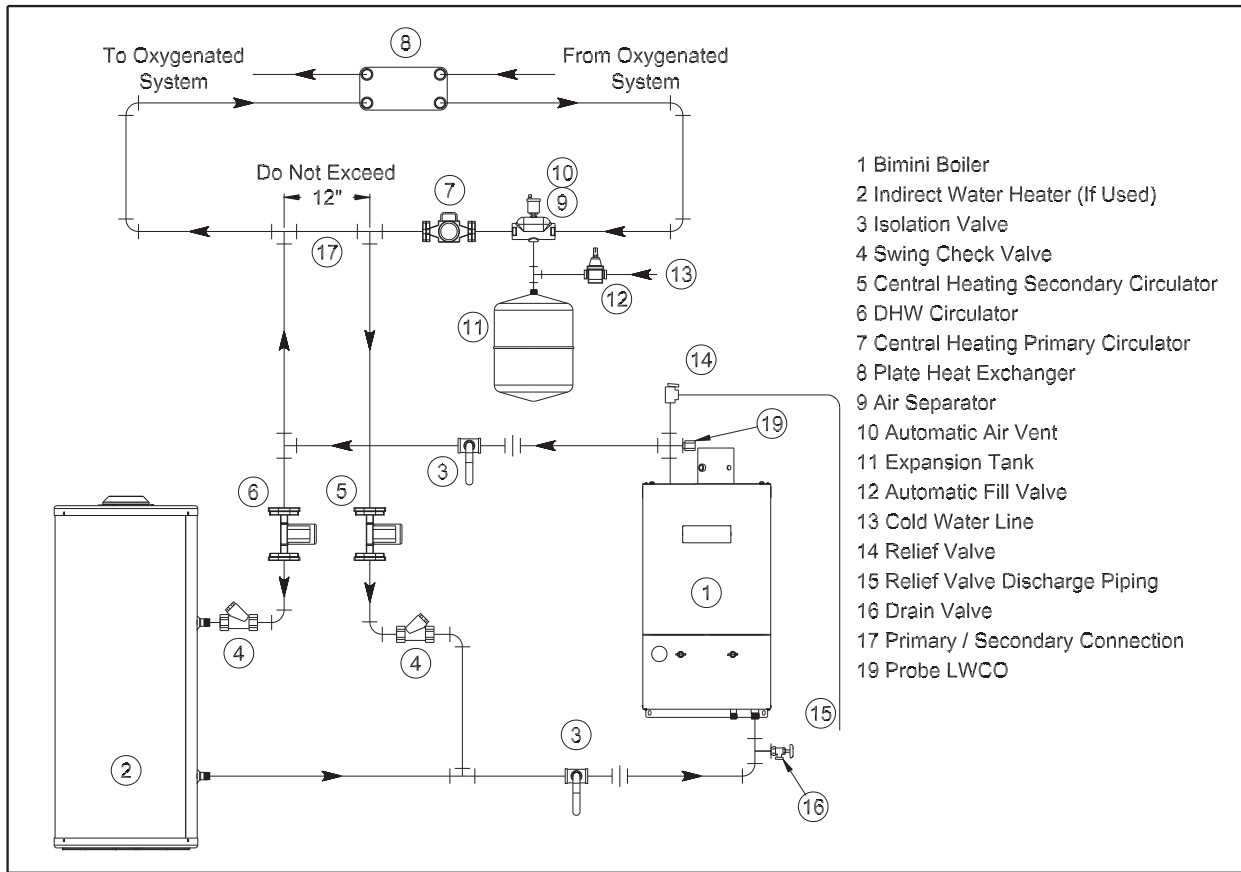

Figure 9.10: Isolation of the Boiler From Oxygenated Water with A Plate Heat Exchanger

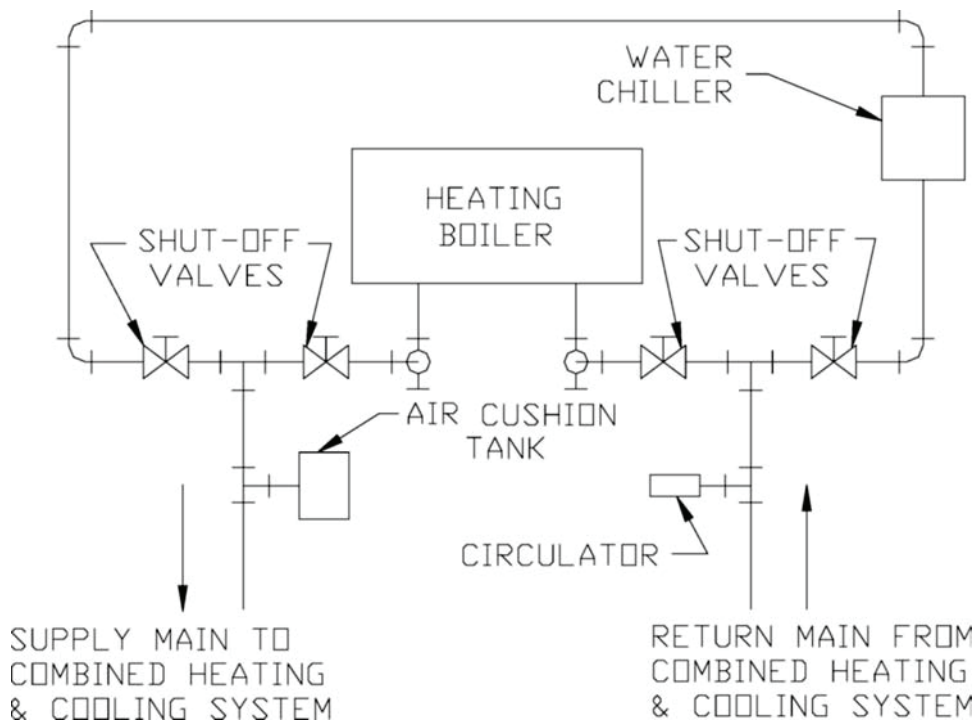

Figure 9.11: Chiller Piping

THIS PAGE
INTENTIONALLY
LEFT BLANK

X Wiring

WARNING

All wiring and grounding must be done in accordance with the authority having jurisdiction or, in the absence of such requirements, with the National Electrical Code /NFPA 70). In Canada, all wiring and grounding must be done in accordance with the Canadian Electrical Code, Part 1 (CSA C22.1 - latest edition).

Figure 10.0 shows the location of both the line voltage and low voltage terminal strips. The line voltage terminal strip is located inside the junction box on the right side of the boiler's control compartment (behind the display). To access it:

- a) Remove the #10 sheet metal screw on the left side of the display and swing the display open.
 - b) Remove the #10 sheet metal screw on the face of the J-box cover and remove it.
- 1) Line Voltage (120 VAC) Field Connections – See Figure 10.1 for line voltage connections. Provide a dedicated circuit for the boiler of 15A or greater. A service switch is recommended and is required by many local codes. Locate this switch in accordance with local codes or, in the absence of any, in a location where it can be safely accessed in an emergency involving the boiler. All 120VAC connections to the boiler itself are made on the terminal strip inside the junction box on the right side of the control compartment behind the display. From left to right, the connections on the terminal strip are:

- Ground
- 120VAC Hot
- 120VAC Neutral
- Boiler Pump Hot
- Boiler Pump Neutral
- DHW Pump Hot
- DHW Pump Neutral
- System Pump Hot
- System Pump Neutral

The use of the pump outputs are as follows (also refer to the Piping Section or Appendix A)

- a) Boiler Pump (“Boiler Loop Pump”) - Pumps water through the boiler upon a call for central heat (CH). Depending on the Domestic Hot Water (DHW) configuration selected, the boiler pump may also pump water through the boiler upon a call for DHW.
- b) DHW Pump (“IWH Circulator”) - Pumps water directly through the indirect water heater. Depending on the DHW configuration selected, the DHW pump may also pump water through the boiler upon a call for DHW. If the boiler is used with a Bimini Buddy containing a 120VAC 3-way diverting valve, the DHW Pump output is connected to this 3-way valve.
- c) System Pump - Pumps water through the radiation. This pump is hydraulically separated from the boiler pump, either by closely spaced tees, or by a Bimini Buddy. The system pump is always on when the system is responding to a call for CH. Depending on the DHW configuration, it may also be on during a call for DHW.

Maximum circulator current draw is 7.4 FLA. See Section XII of this manual for information on setting up the pump operation.

2. Condensate Pump Receptacle - A 120VAC receptacle is located near the condensate trap (Figure 10.2) and is for use with a flue gas condensate pump.

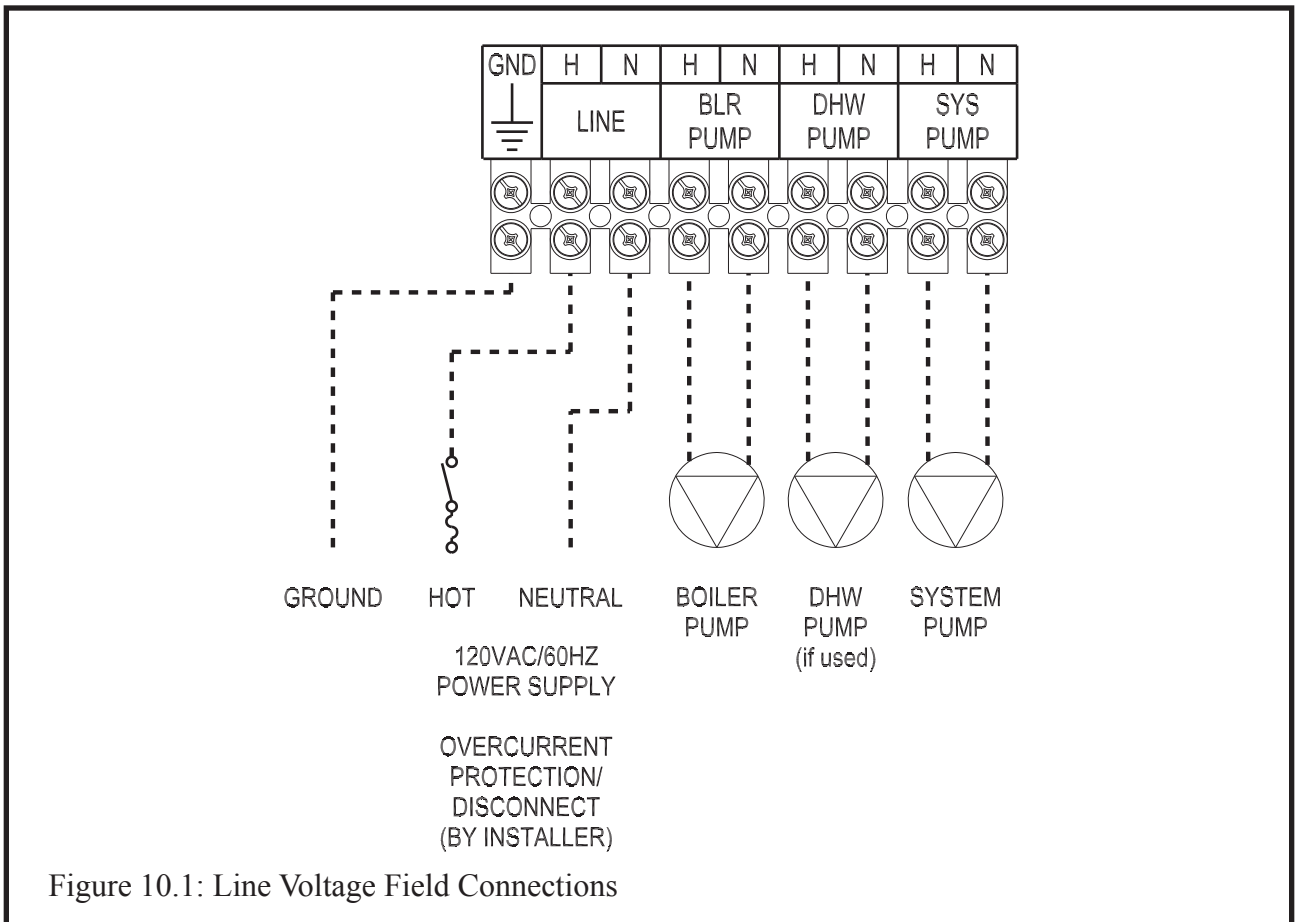
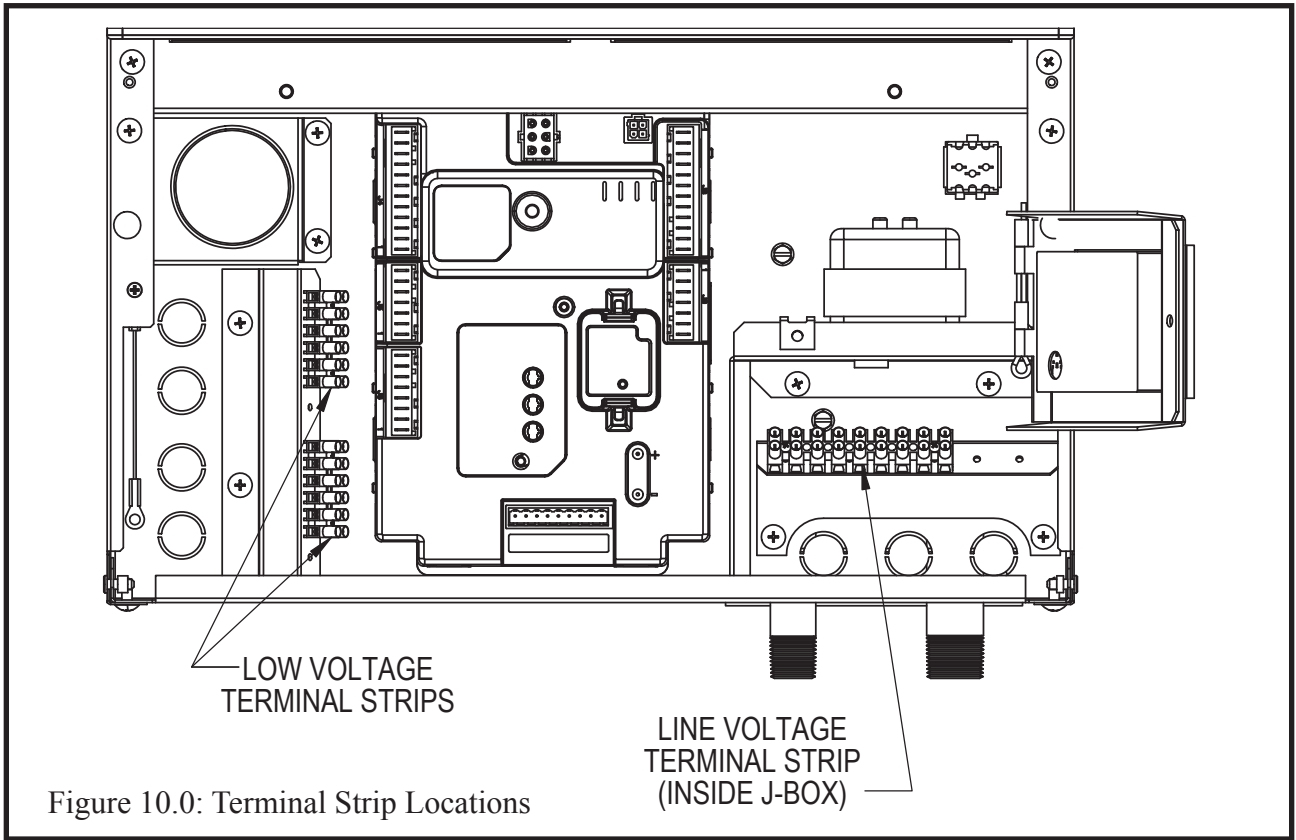

CAUTION

When making low voltage connections, make sure that no external power source is present in the thermostat or limit circuits. If such a power source is present, it could destroy the boiler's control. One example of an external power source that could be inadvertently connected to the low voltage connections is a transformer in old thermostat wiring.

3. Low Voltage Connections – Low voltage Field connections are located on the left side of the control compartment as shown in Figure 10.3 and are listed from top to bottom:

- CH Stat - 24VAC heating thermostat (1)
- CH Stat - 24VAC heating thermostat (2)
- DHW Stat - 24VAC domestic hot water thermostat or Bimini Buddy flow switch (1)
- DHW Stat - 24VAC domestic hot water thermostat or Bimini Buddy flow switch (2)
- Aux Limit - Field supplied low voltage safety limit contacts (1)
- Aux Limit - Field supplied low voltage safety limit contacts (2)
- LT Stat - Not currently used (1)
- LT Stat - Not currently used (2)

- OD Sensor - Honeywell C7089U Outdoor Temperature Sensor (1)
- OD Sensor - Honeywell C7089U Outdoor Temperature Sensor (2)
- Header Sensor - Optional Honeywell 32003971-003 Sensor (1)
- Header Sensor - Optional Honeywell 32003971-003 Sensor (2)
- Alarm Contact (1)
- Alarm Contact (2)
- LT Sensor - Not currently used (1)
- LT Sensor - Not currently used (2)

Refer to Figure 10.3 for low voltage wiring. With the exception of the alarm contacts, external power must not be applied to any of the low voltage terminals - doing so may damage the Sola boiler control. Also note the following:

- a) Auxiliary Limit - The auxiliary limit terminals are intended for use with a field supplied safety device, such as a manual reset high limit. When an external limit is used, the violet jumper between these two terminals must be removed. Failure to remove this jumper will render the external safety devices ineffective.

- b) Outdoor Sensor - Use only the Honeywell C7089U outdoor sensor supplied with the boiler. When this sensor is connected and enabled, the boiler will adjust the target supply water temperature downwards as the outdoor air temperature increases. This sensor should be located on the outside of the structure in an area where it will sense the average air temperature around the house. Avoid placing this sensor in areas where it may be covered with ice or snow. In general, locations where the sensor will pick up direct radiation from the sun should also be avoided. Avoid placing the sensor near potential sources of electrical noise such as transformers, power lines, and fluorescent lighting. Wire the sensor to the boiler using 22 gauge or larger wire. As with the sensor, the sensor wiring should be routed away from sources of electrical noise. Where it is impossible to avoid such noise sources, wire the sensor using a 2 conductor, UL Type CM, AWM Style 2092 shielded cable. Connect one end of the shielding on this cable to ground. See Section XII of this manual for information on enabling the outdoor reset sensor.

- c) Header Sensor - When this sensor is installed and enabled, the boiler will attempt to maintain the target water temperature in the header rather than in the supply. Where the system flow rate varies widely, the use of a header sensor allows the temperature of the water being sent to the radiation to be more accurately controlled. Use only the Honeywell 32003971-003 sensor listed above. Locate this sensor immediately downstream of the second primary-secondary Tee (Figure 10.4). Installation of this sensor in a well, as opposed to on the surface of the header, is highly recommended. The sensor wiring should be routed away from sources of electrical noise. Where it is impossible to avoid such noise sources, wire the sensor using a 2 conductor, UL Type CM, AWM Style 2092, 300Volt 60°C shielded cable. Connect one end of the shielding on this cable to ground. See Section XII for information on enabling the header sensor.

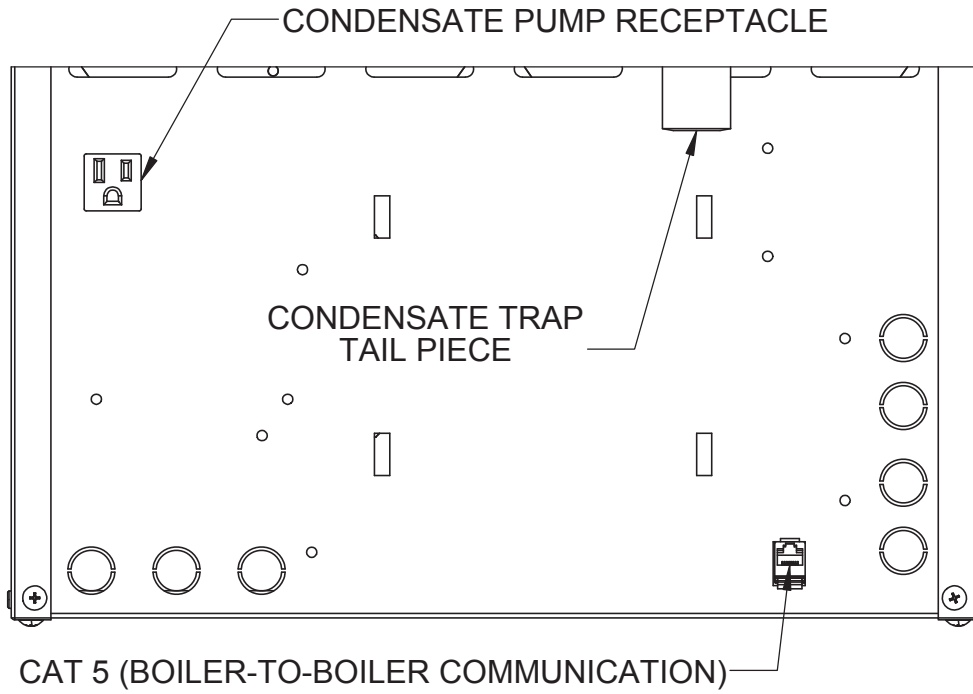

VIEW OF CONTROL BOX FROM INSIDE TRAP COMPARTMENT
(TRAP, RETURN PIPE & GAS PIPE OMITTED FOR CLARITY)

Figure 10.2: Condensate Pump Receptical

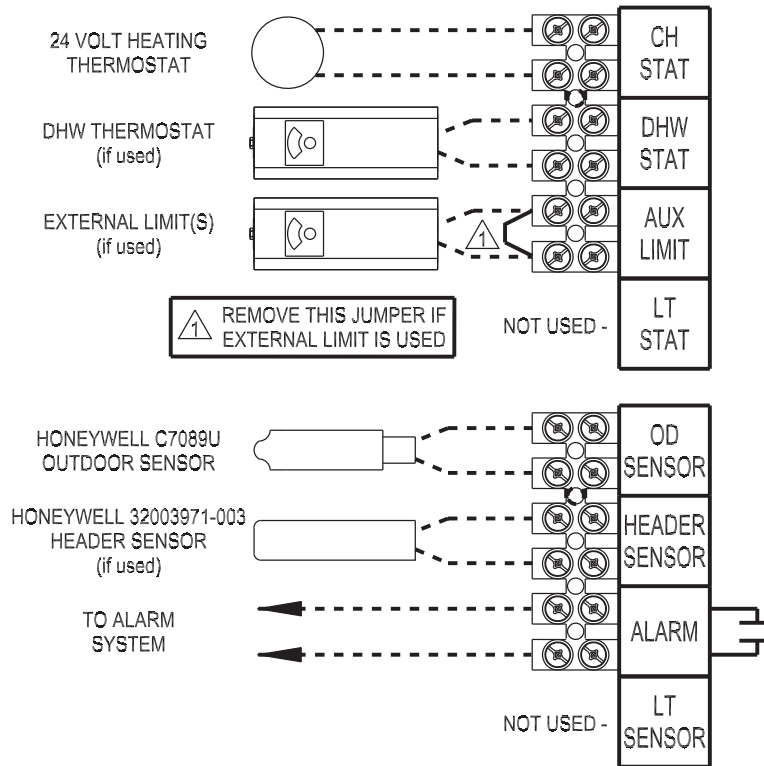

Figure 10.3: Low Voltage Field Wiring

- d) Alarm Contacts - These contacts close when the boiler enters a “hard” lockout (lockout requiring manual reset). They may be used as an input to a building alarm system. Contact rating is 24VAC, 0.63FLA. Do not use for line voltage applications.
- e) Other Connections - A CAT 5 data receptacle is located behind the control compartment and is used for multiple boiler (“Lead-Lag”) installations. See the multiple boiler installation supplement for additional information. A Honeywell EnviraCOM connection is also located as labeled on the Sola control itself.

CAUTION

Do not attempt to use CAT 5 or EnviraCOM connections for any purpose not explicitly permitted by Crown Boiler Company. Attempting to do so may result in unreliable operation and/or damage to controls.

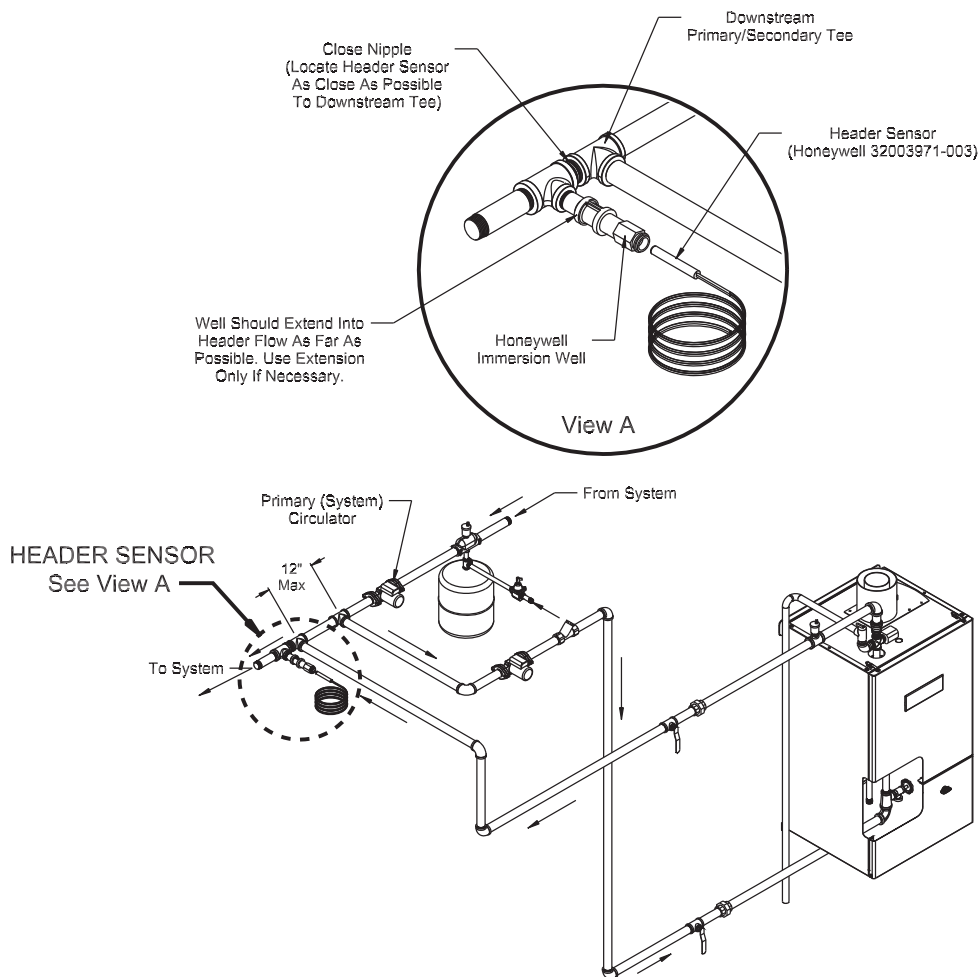
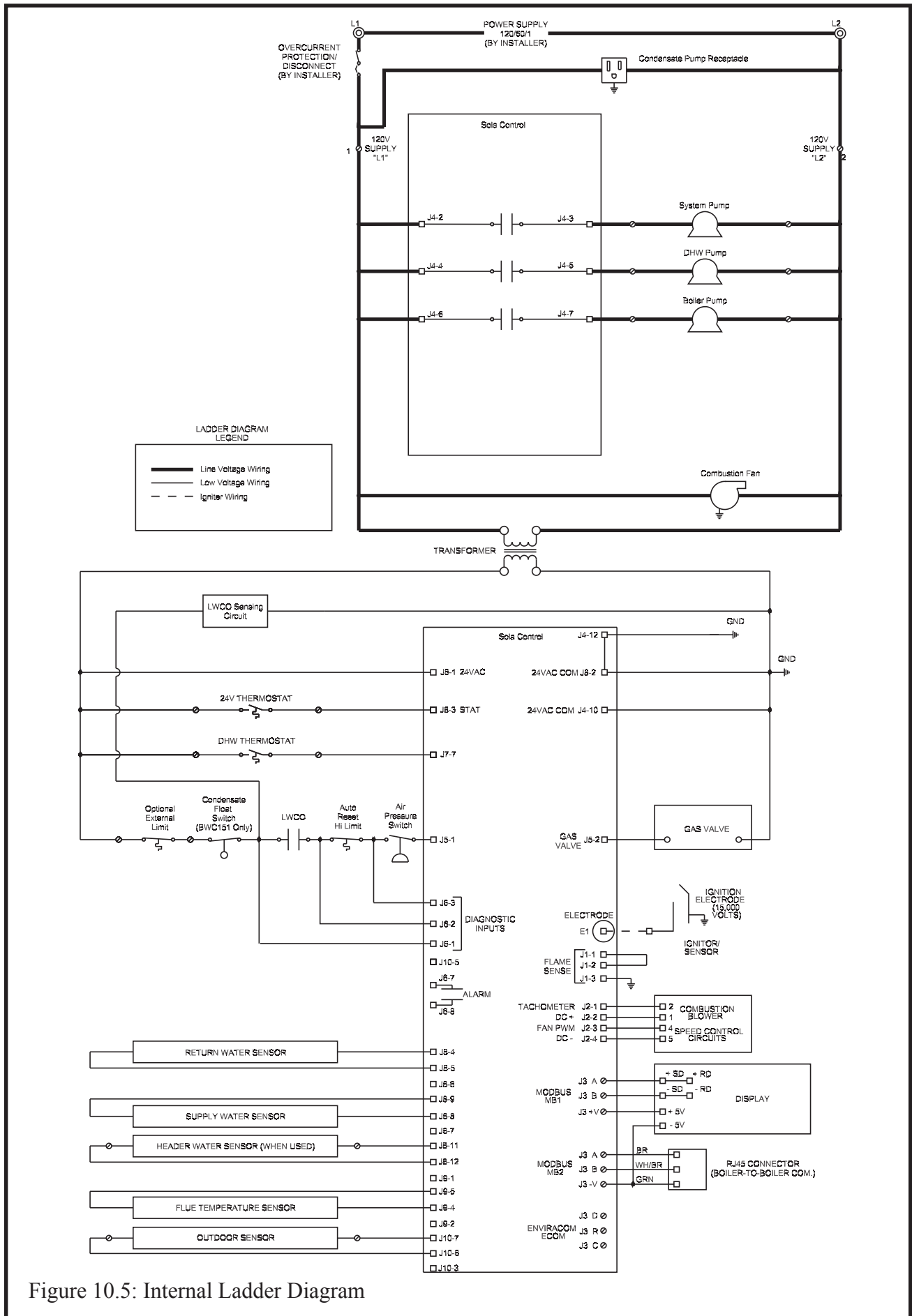

Figure 10.4: Proper Installation of Header Sensor



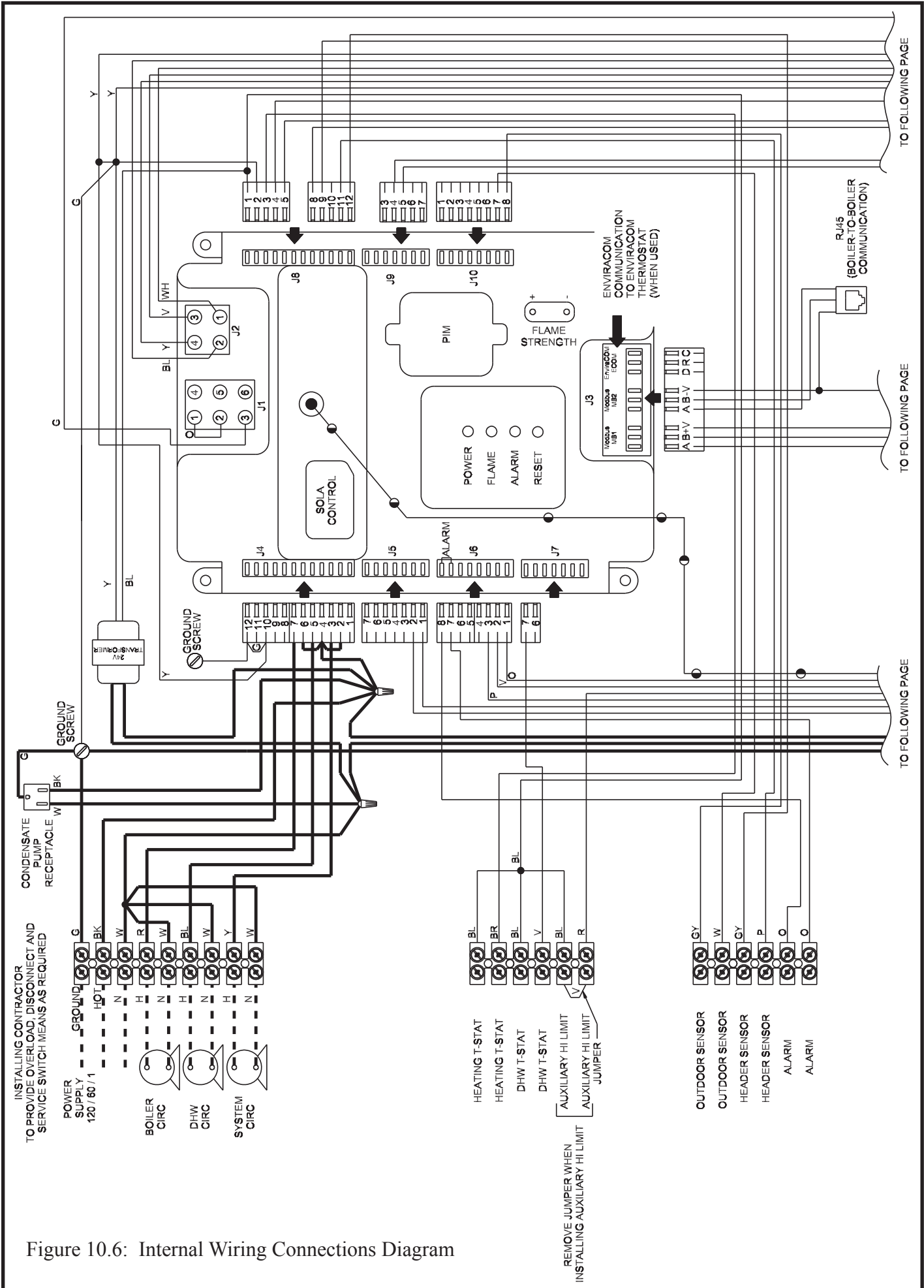
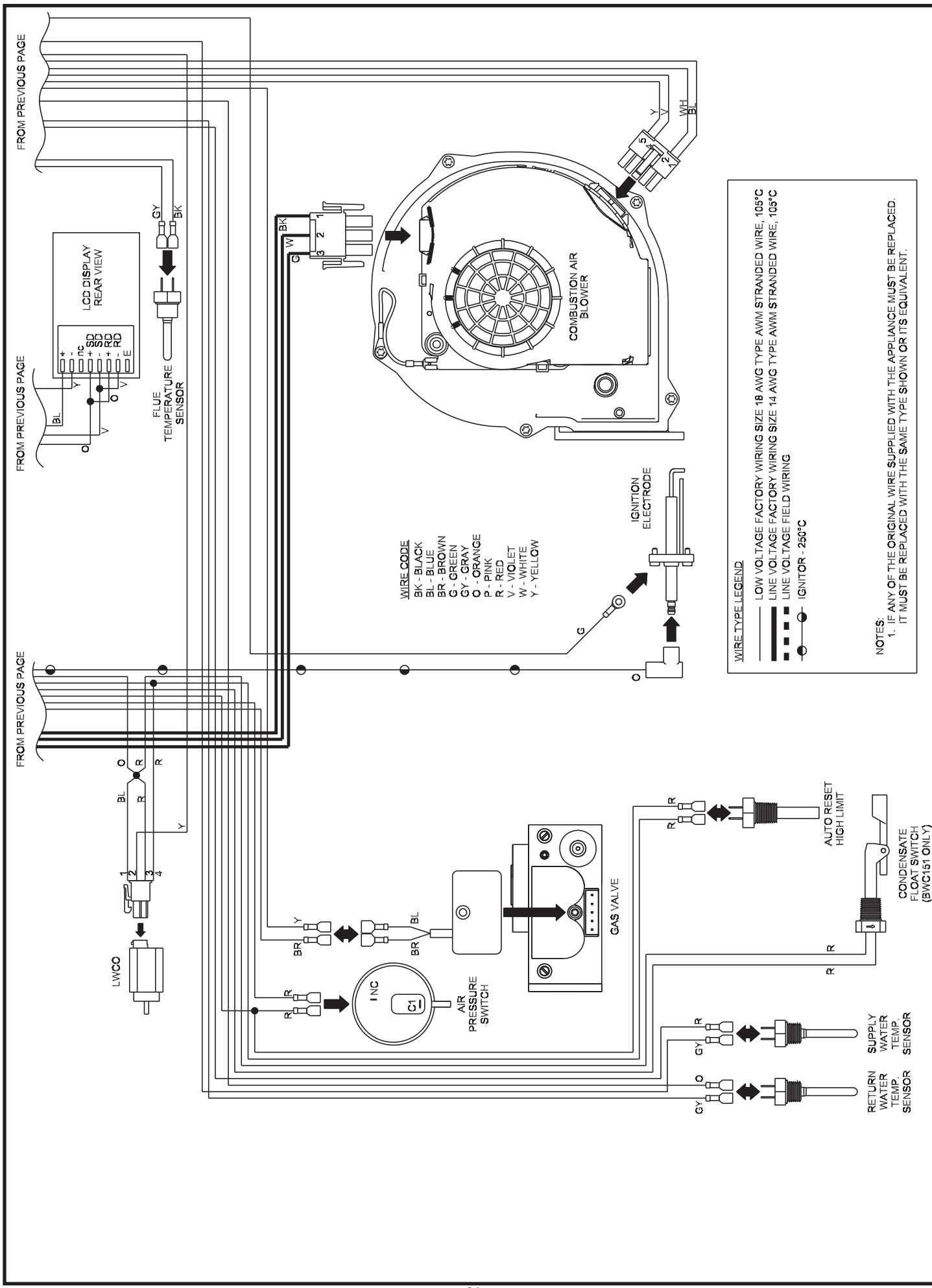

Figure 10.6: Internal Wiring Connections Diagram



WIRE CODE
 BK - BLACK
 BL - BLUE
 BR - BROWN
 G - GREEN
 GY - GRAY
 O - ORANGE
 P - PINK
 R - RED
 V - VIOLET
 W - WHITE
 Y - YELLOW

WIRE TYPE LEGEND

- LOW VOLTAGE FACTORY WIRING SIZE 18 AWG TYPE AWM STRANDED WIRE, 105°C
- LINE VOLTAGE FACTORY WIRING SIZE 14 AWG TYPE AWM STRANDED WIRE, 105°C
- LINE VOLTAGE FIELD WIRING
- IGNITOR - 250°C

NOTES:
 1. IF ANY OF THE ORIGINAL WIRE SUPPLIED WITH THE APPLIANCE MUST BE REPLACED, IT MUST BE REPLACED WITH THE SAME TYPE SHOWN OR ITS EQUIVALENT.

XI Start-up and Checkout

NOTE

Safe lighting and other performance criteria were met with the gas train assembly provided on the boiler when the boiler underwent the test specified in Z21.13.

Use the following procedure for initial start-up of the boiler:

- 1) If not already done, flush the system to remove sediment, flux, and traces of boiler additives. This should be done with the boiler isolated from the system.
- 2) Fill the boiler and hydronic system with water meeting the following requirements below (also see the note on the next page):
 - pH between 6.5 and 8.5
 - Total Solids less than 2500 PPM
 - Hardness less than 120 PPM (7 Grains/Gallon)
 - Pressurize the system to at least 12 psi at the boiler

WARNING

Never attempt to fill a hot empty boiler.

- 3) Check all new piping for leaks and purge piping sections that are filled with air. Refer to the *National Fuel Gas Code* for additional information on testing and purging gas lines.

WARNING

- **Never use a flame to check for gas leaks.**
- **Make sure that the area around the boiler is clear and free from combustible materials, gasoline and other flammable vapors and liquids.**

- 4) Vent system must be complete and free of obstructions before attempting to fire boiler. Make sure that the silicone cure time called for in the vent assembly instructions has passed before firing boiler.
- 5) Inspect all line voltage wiring for loose or uninsulated connections.
- 6) Remove the dust cap from the condensate trap (Fig 7.21). Add water to the trap until water runs out the condensate drain. Reinstall the dust cap.
- 7) Start the boiler using the lighting instructions on page 68. With the boiler powered up, and with no call for heat, the display should look like Figure 11.0a. Once a call for heat is present, it will look like Figure 11.0b.

WATER QUALITY AND BOILER WATER ADDITIVES IMPORTANT NOTE

This boiler is equipped with an aluminum heat exchanger that can be seriously damaged by failure to follow the following guidelines:

1) Flush the system before connecting the boiler - In a replacement installation, flushing the system will remove sediment, solder flux, and traces of old boiler additives. Even if the system is new, do not omit this step - new systems will contain solder flux and may even contain sediment.

2) Make sure that the system is tight - *This is the single most important guideline.* Tap water contains dissolved oxygen which causes corrosion. In a tight system, this oxygen comes out of solution and is quickly removed from the system through the automatic air vent. The system then remains essentially free of oxygen. If the system is not tight, however, frequent additions of make-up water can expose the heat exchanger to oxygen on a continuous basis. In addition, frequent additions of hard make-up water can cause calcium deposits to collect in the heat exchanger, causing severe damage.

To minimize additions of make-up water:

- Inspect the system thoroughly for leaks before placing it in service.
- If the system includes underground piping, or other piping in which a leak might go undetected, consider isolating the boiler from the system with a heat exchanger. Alternatively, consider installing a water meter in the fill line to record additions of make-up water.
- Make sure that the expansion tank is properly sized and in good condition. If it is not, the relief valve may open frequently, resulting in regular additions of make-up water.

3) Radiant Tubing and Oxygen Barriers - Even if the system is tight, oxygen can be introduced into the system through some types of non-metallic tubing used in radiant or snow melt systems. Other non-metallic tubing is equipped with an oxygen barrier to prevent migration of oxygen into the water. If the boiler is to be installed in a system containing non-metallic tubing without an oxygen barrier, it must be isolated from the boiler with a heat exchanger as shown in Figure 9.10.

4) Antifreeze - Do not use antifreeze unless absolutely necessary. If antifreeze must be used, the only permitted antifreezes are:

- Fernox Alphi-11
- Fernox CHP in virgin propylene glycol (available from Crown)
- RhoGard Aluminum Safe Multi-Metal Antifreeze

If either of the above antifreezes are used, test the boiler water on an annual basis to ensure that the antifreeze remains non-corrosive. For Alphi-11 and CHP in propylene glycol, this is done with Fernox test kit I-TK (available from Crown). For other approved brands of antifreeze, consult the antifreeze manufacturer for the recommended means of testing the antifreeze.

5) Other Antifreezes and Boiler Additives - Do not add other additives unless they are specifically approved in writing by Crown for use with this boiler. This includes other “aluminum safe” antifreezes.

6) System PH - Maintain the PH in the system between 6.5 and 8.5.

- 8) The boiler should attempt to fire approximately 30 seconds after a call for heat appears. With the upper front cover removed from the boiler, this try for ignition will appear as an audible spark (lasting approximately 4 seconds) and an audible click from the gas valve. Upon initial start-up, the gas train will be filled with air. Even if the gas line has been completely purged of air, it may take several tries for ignition before a flame is established. If the boiler does not light after three tries for ignition, it will enter a “soft lockout” and will wait for one hour before attempting another ignition sequence. This soft lockout can be reset by interrupting power to the boiler for a few seconds. Once a flame has been established for the first time, subsequent calls for burner operation should result in a flame on the first try.
- 9) If there is a problem that appears before the first try for ignition, or if the boiler fails to light after three tries for ignition, the flashing “Active Fault” button will appear on the Home screen (Figure 11.0c). Touching this button will take the user to the Diagnostics menu where the cause of the problem can usually be found by pressing the flashing button on each successive screen. For more information, see Section XIV of this manual.
- 10) Inspect the flame visible through the window. On high fire the flame should be stable and mostly blue (Fig.11.1). No yellow tipping should be present; however, intermittent flecks of yellow and orange in the flame are normal.
- 11) Check the inlet gas pressure and adjust if necessary. Verify that the inlet gas pressure is between the upper and lower limits shown on the rating plate with all gas appliances on and off.



Figure 11.0a: Home Screen at Power-up (No Call for Heat)



Figure 11.0b: Home Screen on Heat Demand



Figure 11.0c: Home Screen with Active Fault

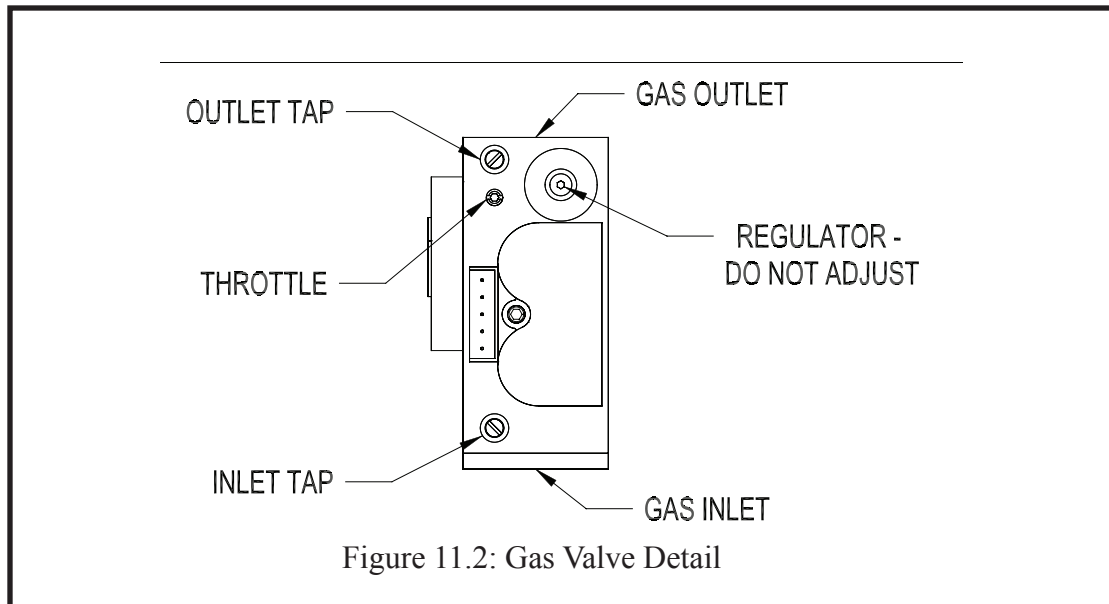
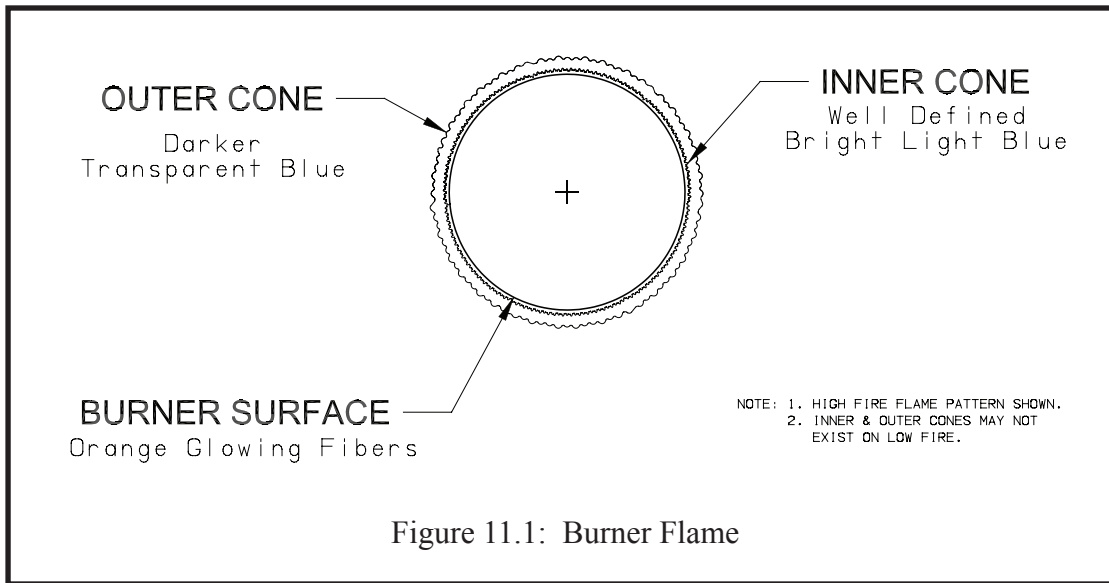

WARNING

Each BWC series boiler is tested at the factory and adjustments to the air-fuel mixture are normally not necessary. Consult a Crown representative before attempting to make any such adjustments. Improper gas valve or mixture adjustments could result in property damage, personal injury, or loss of life.

WARNING

The outlet pressure for the gas valve has been factory set and requires no field adjustment. This setting is satisfactory for both natural gas and propane. Attempting to adjust the outlet pressure may result in damage to the gas valve and cause property damage, personal injury or loss of life.

- 12) Perform a combustion test. Boilers equipped with a concentric or CPVC/PVC vent system have a flue gas sample tap located in the boiler vent collar. For other vent systems, the sample probe may be inserted into the vent terminal. If this is not possible, remove the flue temperature sensor and insert the analyzer probe in the sensor opening. For the boiler to operate, this sensor will need to remain connected to the wiring. If the flue gas sensor is removed, be sure to replace it after combustion testing is complete. Check CO₂ (or O₂) and CO at both high and low fire. The boiler may be temporarily locked into high or low fire as follows:
- From the Home Screen, press “MENU” to enter the main menu.
 - Press “SETTINGS”.
 - If prompted for a password, use the “+1” key to raise the password to “005” and press SUBMIT, then NEXT (if you accidentally scroll past 005, press EXIT to return to the main menu and start over).
 - Review the Warning and press ACCEPT to continue to the Settings Menu.
 - At the Settings Menu select “MANUAL INPUT”.
 - Press HIGH FIRE HOLD or LOW FIRE HOLD as appropriate.

To return the boiler to automatic modulation, press AUTO FIRE. Note: If the Auto Fire button is not pressed, boiler will remain in manual fire until the display returns to the Home Screen. This happens automatically if the screen is not touched for a period of time, which varies depending on which screen is open. From the manual input screen, it takes 12min:45s.

At both high and low fire, CO readings should be less than 75 PPM. Typical CO₂ and O₂ readings are shown in Table 11.3. Final readings should be taken with all doors and covers in place.

Model	Fuel	%CO ₂	%O ₂
BWC070	Natural Gas	9.4	4.4
BWC070	Propane	10.4	5.1
BWC090	Natural Gas	9.5	4.3
BWC090	Propane	10.5	5.0
BWC120	Natural Gas	9.5	4.3
BWC120	Propane	10.5	5.0
BWC151	Natural Gas	9.5	4.3
BWC151	Propane	10.5	5.0

Table 11.3: Typical CO₂/O₂ Combustion Readings

- 13) Test any external limits or other controls in accordance with the manufacturer’s instructions.
- 14) Refer to the Operation Section to set-up the control for the system in which the boiler is installed. Some common set-up tasks include:
- Enabling the outdoor reset (ODR) function.
 - Setting the CH and DHW temperature set-points (as shipped, both setpoints are set to 180°F).
 - Selecting the type of indirect water heater (if any) and location of DHW pumps.
 - Defining the system pump operation.
- 15) Adjust the heating and indirect water heater thermostats to their final set points.

BWC Series Lighting and Operating Instructions

FOR YOUR SAFETY READ BEFORE LIGHTING

WARNING: If you do not follow these instructions exactly, a fire or explosion may result causing property damage, personal injury or loss of life.

- A. This appliance does not have a pilot. It is equipped with an ignition device which automatically lights the burner. Do not try to light the burner by hand.
- B. **BEFORE OPERATING** smell all around the appliance area for gas. Be sure to smell next to the floor because some gas is heavier than air and will settle on the floor.
- WHAT TO DO IF YOU SMELL GAS**
- Do not try to light any appliance.
 - Do not touch any electric switch; do not use any phone in your building.
 - Immediately call your gas supplier from a neighbor's phone. Follow the gas supplier's instructions.
- If you cannot reach your gas supplier, call the fire department.
- C. Use only your hand to turn the gas control knob. Never use tools. If the knob will not push in or turn by hand, don't try to repair it, call a qualified service technician. Force or attempted repair may result in a fire or explosion.
- D. Do not use this appliance if any part has been under water. Immediately call a qualified service technician to inspect the appliance and to replace any part of the control system and any gas control which has been under water.

OPERATING INSTRUCTIONS

1. **STOP!** Read the safety information above on this label.
2. Set the thermostat to the lowest setting.
3. Turn off all electric power to the appliance.
4. This appliance is equipped with an ignition device which automatically lights the burner. Do not try to light the burner by hand.
5. Turn the external boiler manual gas valve T-handle counterclockwise to open gas supply. 
6. Smell for gas in the boiler enclosure. If you smell gas, **STOP!** Follow "B" in the safety information above. If you don't smell gas, go to the next step.
7. Turn on all electric power to the appliance.
8. Set the thermostat to the desired setting.
9. If the appliance will not operate, follow the instructions "To Turn Off Gas To Appliance" below and call your service technician or gas supplier.

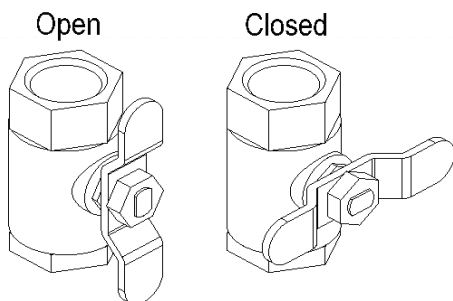

External Boiler Manual Gas Valve

TO TURN OFF GAS TO THE APPLIANCE

1. Turn off all electric power to the appliance if service is to be performed.
2. Set the thermostat to the lowest setting.
3. Turn the external boiler manual gas valve T-handle clockwise to close the gas supply. 

XII Operation

A. General Information

The BWC boiler uses the microprocessor based Honeywell “Sola” control to manage all boiler functions including flame supervision and modulation. Two set point or “target” boiler supply temperatures are stored in the Sola’s memory; one for space heating (CH) and one for domestic hot water (DHW) production. If an outdoor temperature sensor is connected to the boiler, and enabled, the space heating supply set point will automatically shift downward as the outdoor temperature increases. For more information on this feature see the discussion on boiler water reset below.

The Sola modulates the boiler input by varying the fan speed. As the fan speed increases, so does the amount of gas drawn into the blower. As a result, a fairly constant air-fuel ratio is maintained across all inputs. The Sola determines the input needed by looking at both current and recent differences between the supply temperature and the set point temperature. As the supply temperature approaches the set point temperature, the fan will slow down and the input will drop. Depending on the model boiler, the minimum input is between 1/3 and 1/5 of maximum input.

The Sola also monitors boiler return and flue temperatures. In addition, all other safety controls, including the low water cut-off and safety limit, are connected into the Sola. The Sola uses inputs from all of these controls to either shut down the boiler when an unsafe condition exists or, in some cases, to correct the problem.

Finally, the basic Sola controls up to three pumps:

- Boiler Loop Pump
- DHW pump (or Bimini Buddy zone valve)
- System pump

Refer to the Piping Section or Appendix A for the location of these pumps

The touch screen display on this boiler has three basic functions:

- 1) To allow the professional HVAC technician to set-up this boiler so that it will work properly in the system to which it is connected.
- 2) To indicate the current status of the boiler and to provide information that will assist the professional HVAC technician in solving problems with the boiler and/or system.
- 3) To advise the homeowner if there is a problem which requires professional service.

A map of the basic menu structure is shown in Figure 12.0. In order to prevent unauthorized or accidental adjustments, access to menus, which change settings and boiler operation, is password protected. In general, if a menu is not touched for 255 seconds, the display backs up to the previous menu. Once the Home Screen is returned to, the password must be reentered in order to regain access to protected menus (this feature prevents the boiler from being permanently left in operation without password protection).

B. Configuring the Control

Use the Configuration Menu to provide the boiler with basic information about the type of system to which it is connected. On a new installation configure the boiler first, then go to the Settings Menu to set parameters such as target water temperatures. A map of the Configuration Menu structure is shown in figure 12.1. To configure the boiler:

- 1) From the Home Screen (shown in Figure 12.0) , press “MENU” to enter the Main Menu:
 - a) Press “CONFIGURE”
 - b) When prompted for a password, use the “+1” key to raise the password to “005”. Press SUBMIT, then NEXT (if you accidentally scroll past 005, press EXIT to return to the main menu and start over).
 - c) Review the Warning and press ACCEPT to continue to the Configuration Menu.

IMPORTANT

This boiler is equipped with a feature that saves energy by reducing the boiler water temperature as the heating load decreases. This feature is equipped with an override which is provided primarily to permit the use of an external energy management system that serves the same function. **THIS OVERRIDE MUST NOT BE USED UNLESS AT LEAST ONE OF THE FOLLOWING CONDITIONS IS TRUE:**

- An external energy management system is installed that reduces the boiler water temperature as the heating load decreases.
- This boiler is not used for any space heating.
- This boiler is part of a modular or multiple boiler system having a total input of 300,000 BTU/hr or greater.

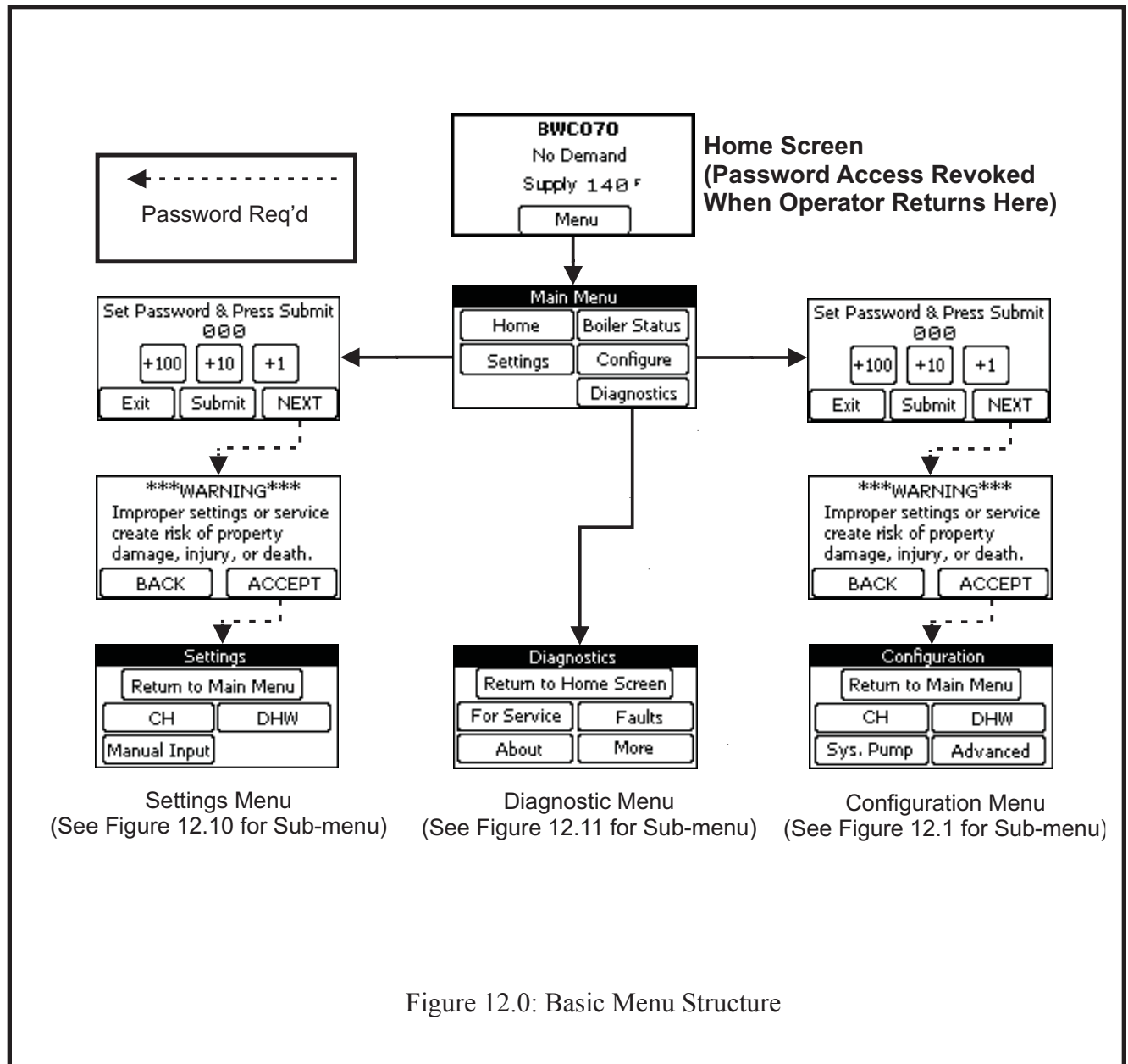

Figure 12.0: Basic Menu Structure

- 2) Press the CH Button to access central heating options. These include:
- a) Setpoint Location - Identifies the sensor that will be used to obtain the target water temperature when the boiler is responding to a call for heat. Choices include:
 - **Supply** (Generally Recommended) - Boiler attempts to obtain the target temperature during a call for heat at the supply sensor built into the boiler.
 - **Header** - Boiler attempts to obtain the target temperature during a call for heat at a Honeywell 32003971-003 sensor (not included) that must be installed in the header as shown in Figure 10.4 of this manual.
 - b) Outdoor Reset - Determines whether or not the outdoor reset function is enabled when the boiler is responding to a call for heat. Choices include:
 - **Outdoor Reset Enabled** - When the boiler is responding to a call for heat, the target water temperature will adjust downward (within certain limits) as the outdoor temperature increases. The graph in Figure 12.9 shows how the target water temperature changes with outdoor temperature. Figure 12.9 shows the default reset curve; the “ends” of this curve can be changed in the Settings Menu.
 - **Outdoor Reset Disabled** - When the boiler is responding to a call for heat, the target water temperature is fixed regardless of what the outdoor temperature is. This fixed setpoint can be changed in the Settings Menu. Outdoor reset function should not be disabled unless at least one of the conditions listed in the “IMPORTANT” box on page 69 is met.
 - c) If you have enabled outdoor reset, press the NEXT key to access two more options related to outdoor reset only. Otherwise, press the EXIT button to return the Configuration Menu and skip to Step 3.
 - d) Warm Weather Shutdown (WWSD) - Determines how the boiler responds to a call from the heating thermostat if the outdoor temperature is “warm”.
 - **WWSD Disabled** - The boiler will always respond to a call for heat regardless of the outdoor temperature.
 - **WWSD Enabled** - When the outdoor temperature is above the WWSD Outdoor Temperature setting, the boiler will ignore a call for space heat (CH) from the thermostat.
 - e) ODR Boost - Determines if the boiler automatically increases the target temperature above that determined by the reset curve when it encounters a long call for space heat:
 - **ODR Boost Disabled** (Generally Recommended) - When responding to a call for heat, the target water temperature is determined solely by the outdoor temperature.
 - **ODR Boost Enabled** - When a call for heat first appears, the target water temperature is determined by the reset curve. If the call for heat lasts for 30 minutes, this target temperature is increased by 10°F. The target temperature is then increased in 10°F increments at 30 minute intervals until one of the following happens:
 - * The call for heat ends.
 - * The target water temperature is 6°F below the top of the reset curve (174°F in the example shown in Figure 12.9)

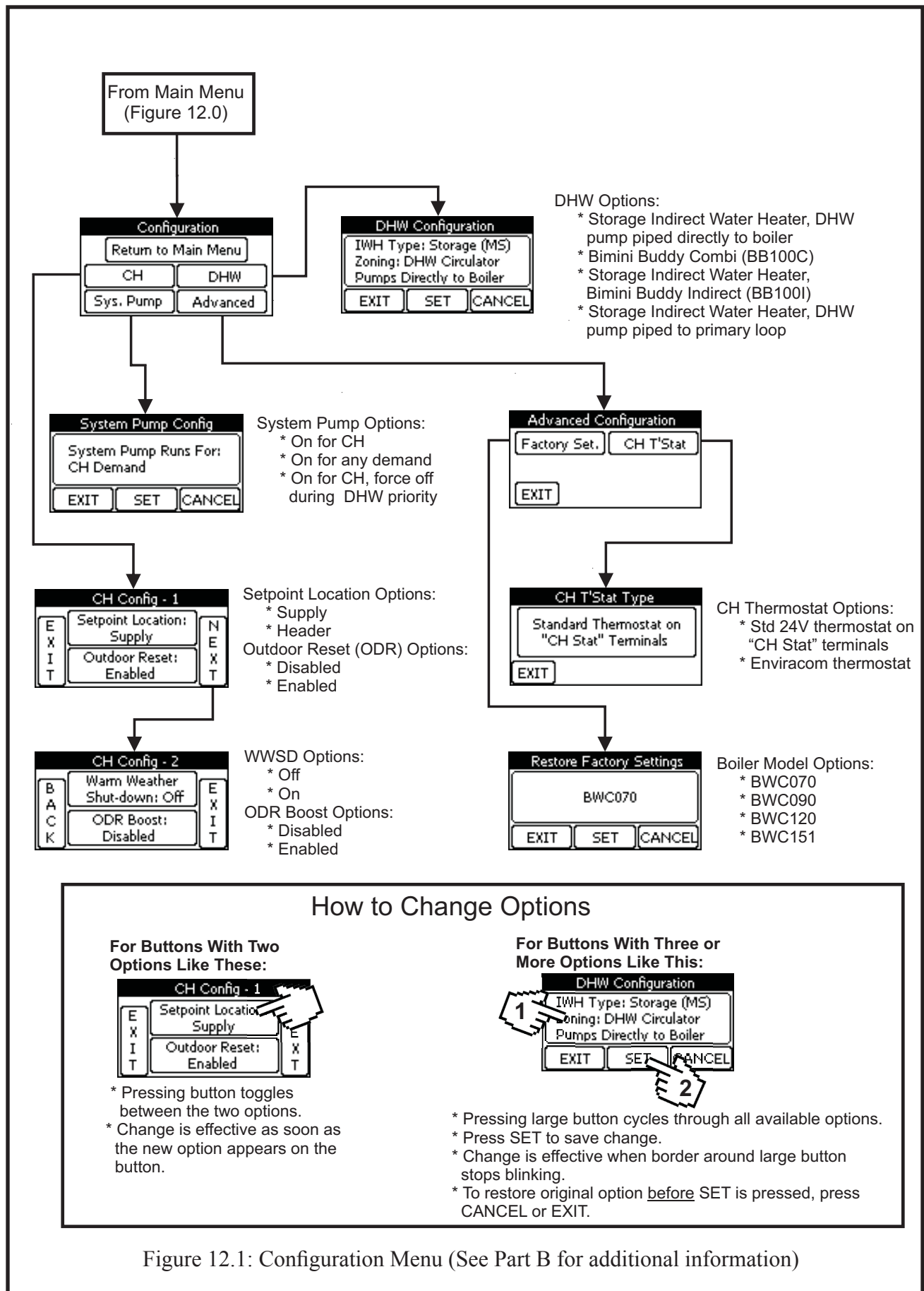

Figure 12.1: Configuration Menu (See Part B for additional information)

- f) Press EXIT to return to the Configuration Menu.
- 3) If this boiler is installed with an indirect water heater, which sends a DHW demand directly to the boiler, press the DHW button on the Configuration Menu. If this is a heat only installation, or if the indirect water heater sends DHW demands to an external zoning panel, skip to Step 4. There are four possible DHW configurations. Each of these options is described below and also summarized in Table 12.6.

Option #1: Indirect Water Heater Type: Storage, Zoning: DHW Circulator Pumps Directly to Boiler - An example of this type of system is shown in Figure 12.2. When this option is selected, the system operates as follows:

- a) Boiler pump only runs during a call for central heat.
- b) DHW pump circulates water through both the indirect water heater and the boiler when the boiler is responding to a call for DHW
- c) A call for DHW is initiated from a thermostat (such as the L4006A supplied with the Crown Mega-Stor and Maxi-Therm) on the indirect water heater. This thermostat controls the DHW temperature.
- d) The target boiler water temperature during a call for DHW is set to a fixed value (default setting =180°F).

Option #2: Indirect Water Heater Type: Bimini Buddy BB100C (Plate HX), Zoning: 120V 3-Way Valve - This option is selected when the boiler is used with a Bimini Buddy Combi near boiler piping package (Figure 12.3). When this option is selected, the system operates as follows:

- a) Boiler pump runs during calls for both central heat and DHW.
- b) The 120VAC 3-way valve supplied with the Bimini Buddy is connected to the “DHW Pump” terminals. This valve is energized only during a call for heat. During a call for DHW this valve remains de-energized, so that all boiler water flow is through the plate heat exchanger on the BB100C.
- c) A call for DHW is initiated from the flow switch in the BB100C
- d) The target boiler water temperature during a call for DHW is set to the desired potable water temperature (default setting =120°F).

Option #3: Indirect Water Heater Type: Storage (MS) Bimini Buddy BB100I, Zoning: 120V 3-Way Valve - This option is selected when the boiler is used with a Bimini Buddy Indirect near boiler piping package (Figure 12.4). When this option is selected, the system operates as follows:

- a) Boiler pump runs during calls for both CH and DHW.
- b) The 120VAC 3-way valve supplied with the Bimini Buddy is connected to the “DHW Pump” terminals. This valve is energized only during a call for heat. During a call for DHW this valve remains de-energized, so that all boiler water flow is through the indirect water heater.
- c) A call for DHW is initiated from a thermostat (such as the L4006A supplied with the Crown Mega-Stor and Maxi-Therm) on the indirect water heater. This thermostat controls the DHW temperature.
- d) The target boiler water temperature during a call for DHW is set to a fixed value (default setting =180°F).

Option #4: Indirect Water Heater Type: Storage, Zoning: DHW Circulator Pumps to Primary Loop - Two examples of this type of system are shown in Figures 12.5 and 12.8. Note that for the system shown in Figure 12.8, the system pump must be set to run on any demand (see Step 4). When Option 4 is selected, the system operates as follows:

- a) Boiler pump runs during calls for both central heat and DHW.
- b) DHW pump circulates water through the indirect water heater during call for DHW
- c) A call for DHW is initiated from a thermostat (such as the L4006A supplied with the Crown Mega-Stor and Maxi-Therm) on the indirect water heater. This thermostat controls the DHW temperature.
- d) The target boiler water temperature during a call for DHW is set to a fixed value (default setting =180°F).

To change the DHW configuration, press the large button containing the description repeatedly until the desired description is reached. When the selection is changed, this button will flash. When the desired configuration is reached, press SET to select it. When this change is accepted by the control, the button will stop flashing. Press EXIT to Return to the Configuration Menu.

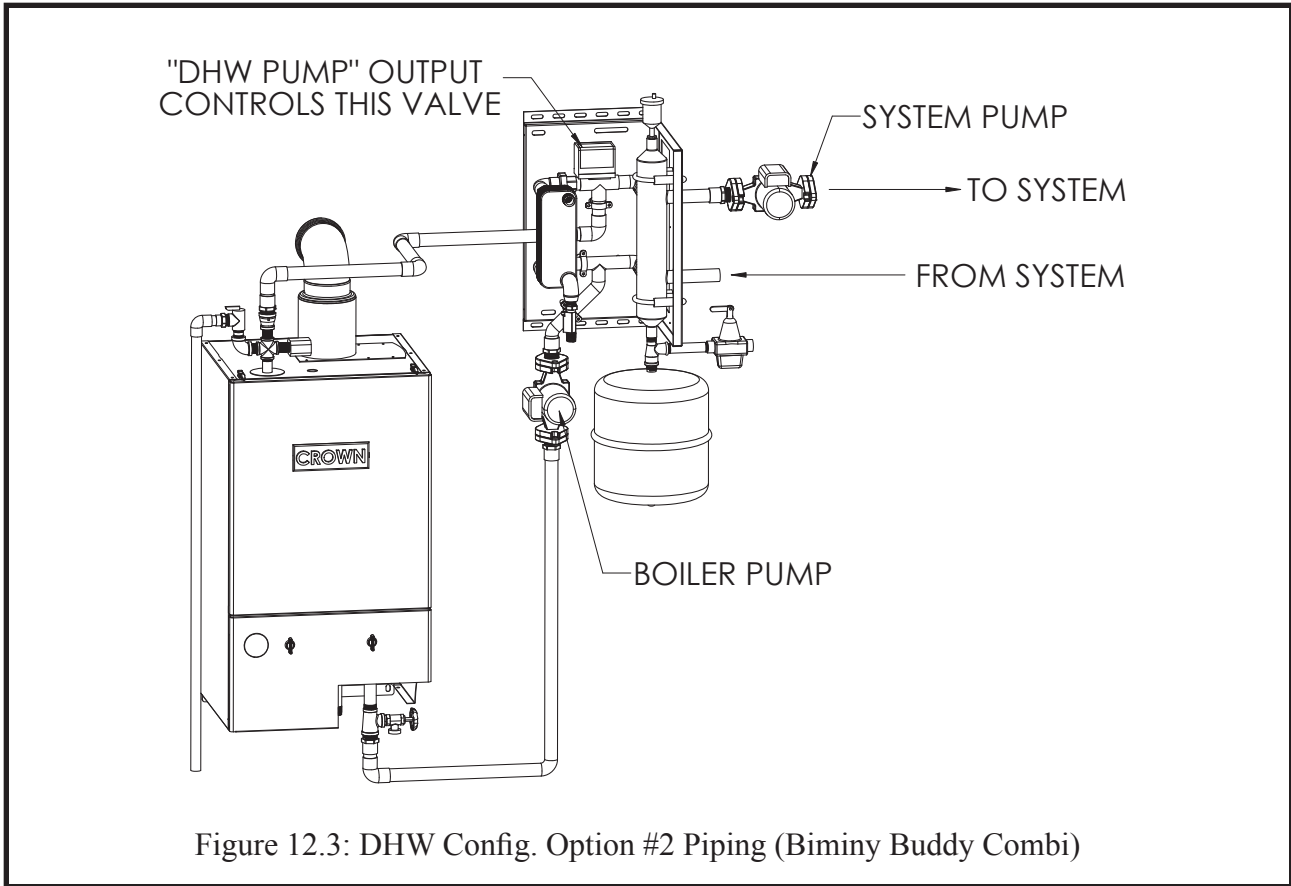
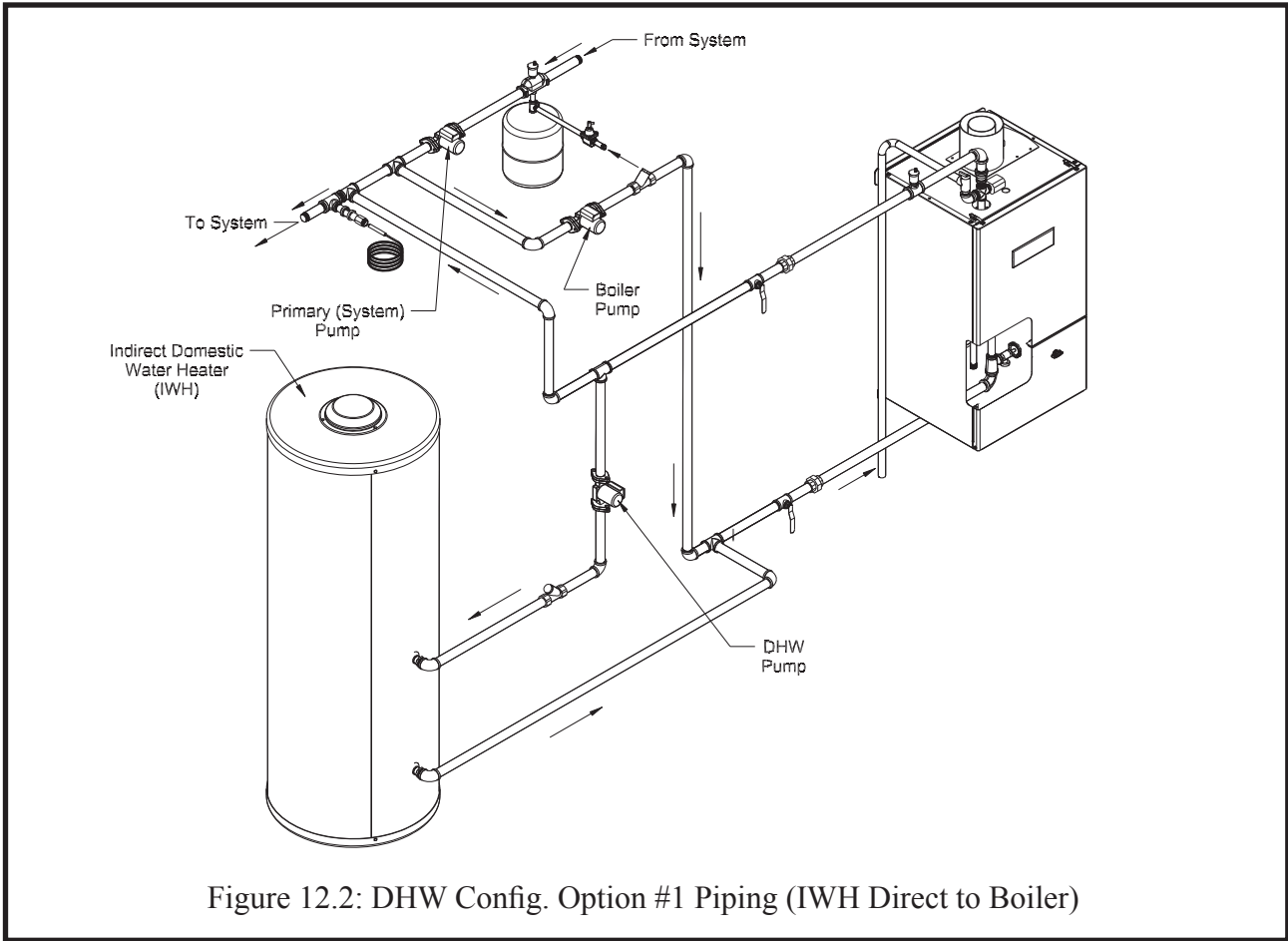

DHW Priority - Like all boilers, the BWC is capable of regulating only one target boiler water temperature at any given time. This means that priority must be given to either the CH or DHW target temperature. In addition, it may be undesirable, or even impossible, to operate the pumps needed for both CH and DHW at the same time. For this reason, the Bimini gives priority to the DHW demand for the first 60 minutes during which both calls for heat continuously exist. If there are still simultaneous calls for DHW and CH at the end of this time, the boiler will then attempt to maintain the target CH temperature and operate the pump/s needed to satisfy the call for heat per Tables 12.6 and 12.7. The boiler will once again give priority to DHW when either of the following events occur:

- The call for CH ends.
- The call for DHW is removed and then restored.

If it is desired to circulate water through both the indirect water heater and the heating zones when there are both CH and DHW demands, pipe the boiler and indirect water heater as shown in either figure 12.5 or 12.8 and select Option #4 above. Also refer to the next section for system pump settings. Note that the target water temperature will still change from that for DHW to CH if the simultaneous demand exceeds 60 min.

4) Press the SYS. PUMP button to select the desired operation of the system pump. There are three options:

- **System Pump Runs for CH Demand** - The system pump runs during a call for central heat regardless of whether or not there is a also a call for DHW.
- **System Pump Runs for Any Demand** - The system pump runs during a call for either CH or DHW. This option must be selected when the indirect water heater is piped as shown in Figure 12.8.
- **System Pump Runs for CH, Off for DHW** - The system pump will not run when there is a call for both CH and DHW until one of the following happens:
 - * The call for DHW ends
 - * The DHW priority time expires

To change the system pump configuration, press the large button containing the system pump description repeatedly until the desired description is reached. When the selection is changed, this button will flash. When the desired configuration is reached, press SET to select it. When this change is accepted by the control, the button will stop flashing. Press EXIT to Return to the Configuration Menu.

5) Pressing the ADVANCED button on the configuration menu takes the user to the Advanced Configuration menu. This menu allows the user to access rarely needed configuration options. These include:

FACTORY SET - This button allows the user to restore all factory configuration and setting options. This function can be used to restore all factory settings if a large number of settings are suspect or if the original control is replaced by one that is programmed for use on another size Crown Bimini. Pressing this button brings up the screen shown in Figure 12.1. Press the model number button until the desired model number is reached. When the selection is changed, this button will flash. When the desired model is reached, press SET to select it. When this change is accepted by the control, the button will stop flashing. Press EXIT to Return to the Advanced Configuration Menu. Repeat the set-up process that starts at the beginning of this Section (XII).

CH T'STAT - This button can be used to change the type of thermostat used to detect a call for CH from a standard 24VAC thermostat to a Honeywell EnviraCOM thermostat, such as the T9421C. Pressing this button brings up a screen with a button that toggles the thermostat selection between the two types of thermostats.

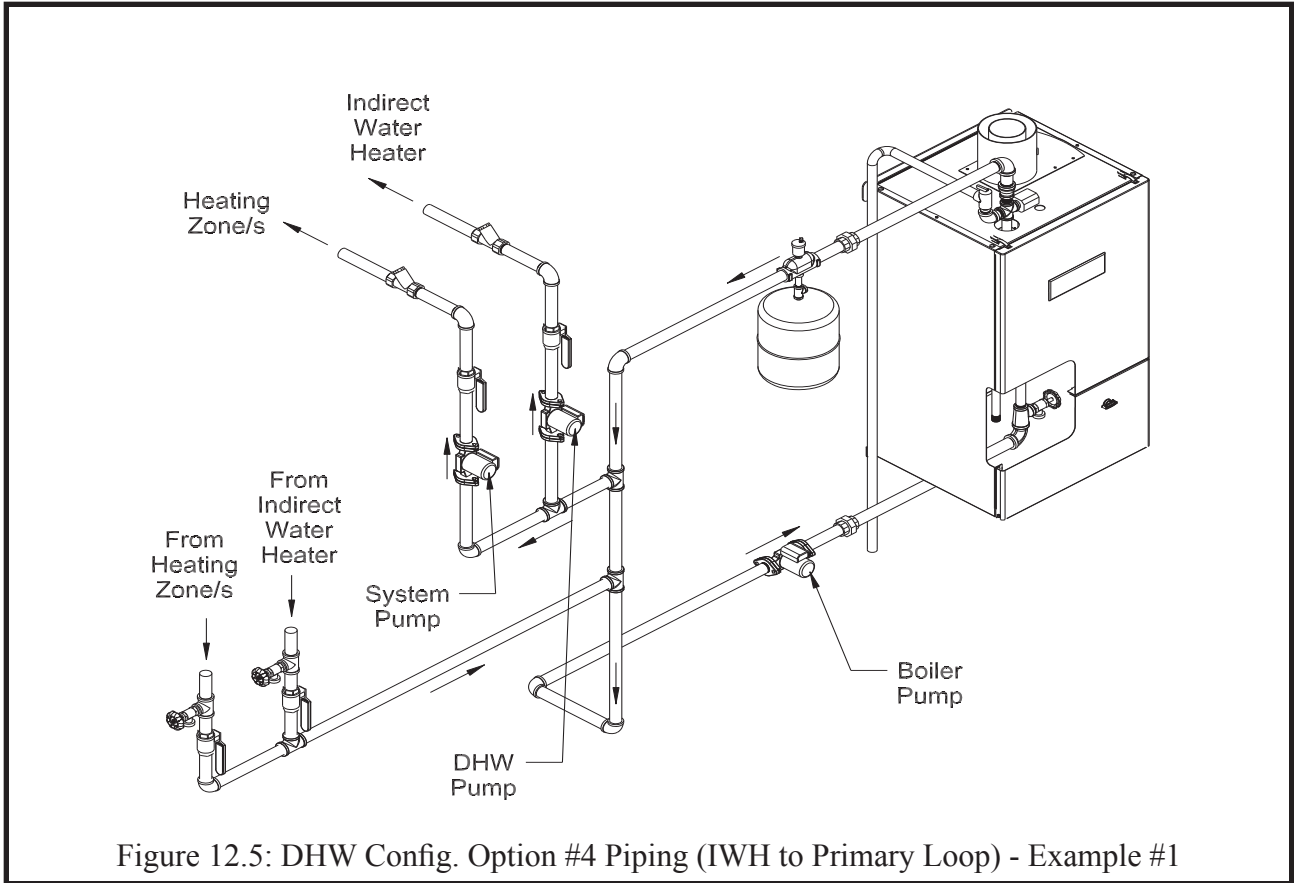
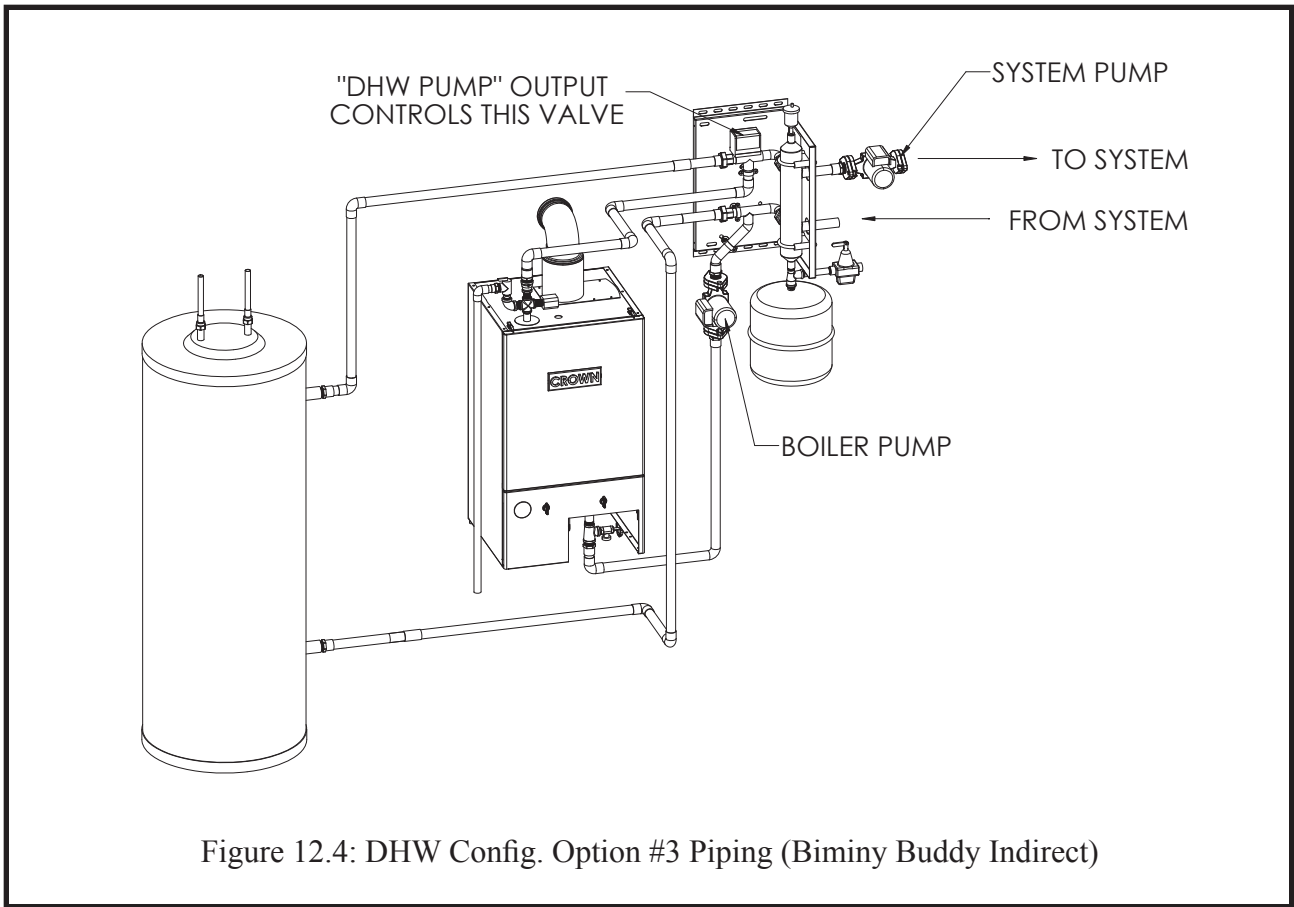

Table 12.6: Summary of Boiler and DHW Pump Behavior

DHW Option #	Description	Status of:	Demands				
			None	CH Only	DHW Only	CH +DHW (< 60 min)	CH +DHW (> 60 min)
1	<ul style="list-style-type: none"> Indirect Water Heater Circ Zoning DHW Pumps directly to Boiler 	Boiler Pump	OFF	ON	OFF	OFF	ON
		DHW Pump	OFF	OFF	ON	ON	OFF
		Target Temp	NONE	CH	DHW	DHW	CH
2	<ul style="list-style-type: none"> Bimini Buddy Combi Plate HX 120VAC 3-way Z.V. (Wired in place of DHW Pump) 	Boiler Pump	OFF	ON	ON	ON	ON
		3-Way Valve	OFF (DHW)	ON (CH)	OFF (DHW)	OFF (DHW)	ON (CH)
		Target Temp	NONE	CH	DHW	DHW	CH
3	<ul style="list-style-type: none"> Bimini Buddy Indirect Indirect Water Heater 120VAC 3-way Z.V. (Wired in place of DHW Pump) 	Boiler Pump	OFF	ON	ON	ON	ON
		3-Way Valve	OFF (DHW)	ON (CH)	OFF (DHW)	OFF (DHW)	ON (CH)
		Target Temp	NONE	CH	DHW	DHW	CH
4	<ul style="list-style-type: none"> Indirect Water Heater Circ Zoning DHW Pumps to primary loop 	Boiler Pump	OFF	ON	ON	ON	ON
		DHW Pump	OFF	OFF	ON	ON	ON
		Target Temp	NONE	CH	DHW	DHW	CH

Table 12.7: Summary of System Pump Behavior

System Pump Options	Demands				
	None	CH Only	DHW Only	CH +DHW (< 60 min)	CH +DHW (> 60 min)
System Pump runs for: CH Demand	OFF	ON	OFF	ON	ON
System Pump runs for: Any Demand	OFF	ON	ON	ON	ON
System Pump runs for: CH, Off for DHW Priority	OFF	ON	OFF	OFF	ON

C. Changing Settings

Use the Settings Menu to change temperature setpoints and to temporarily lock the boiler in high or low fire. On a new installation configure the boiler first, then go to the Settings Menu. A map of the Settings Menu structure is shown in Figure 12.10. To change settings:

- 1) From the Home Screen (shown in Figure 12.0) , press “MENU” to enter the Main Menu:
 - a) Press “SETTINGS”
 - b) When prompted for a password, use the “+1” key to raise the password to “005”. Press SUBMIT, then NEXT (if you accidentally scroll past 005, press EXIT to return to the main menu and start over).
 - c) Review the Warning and press ACCEPT to continue to the Settings Menu.
 - d) Note: If you go from the Configurations Menu to the Settings Menu without returning to the Home Screen, you will not have to reenter a password.

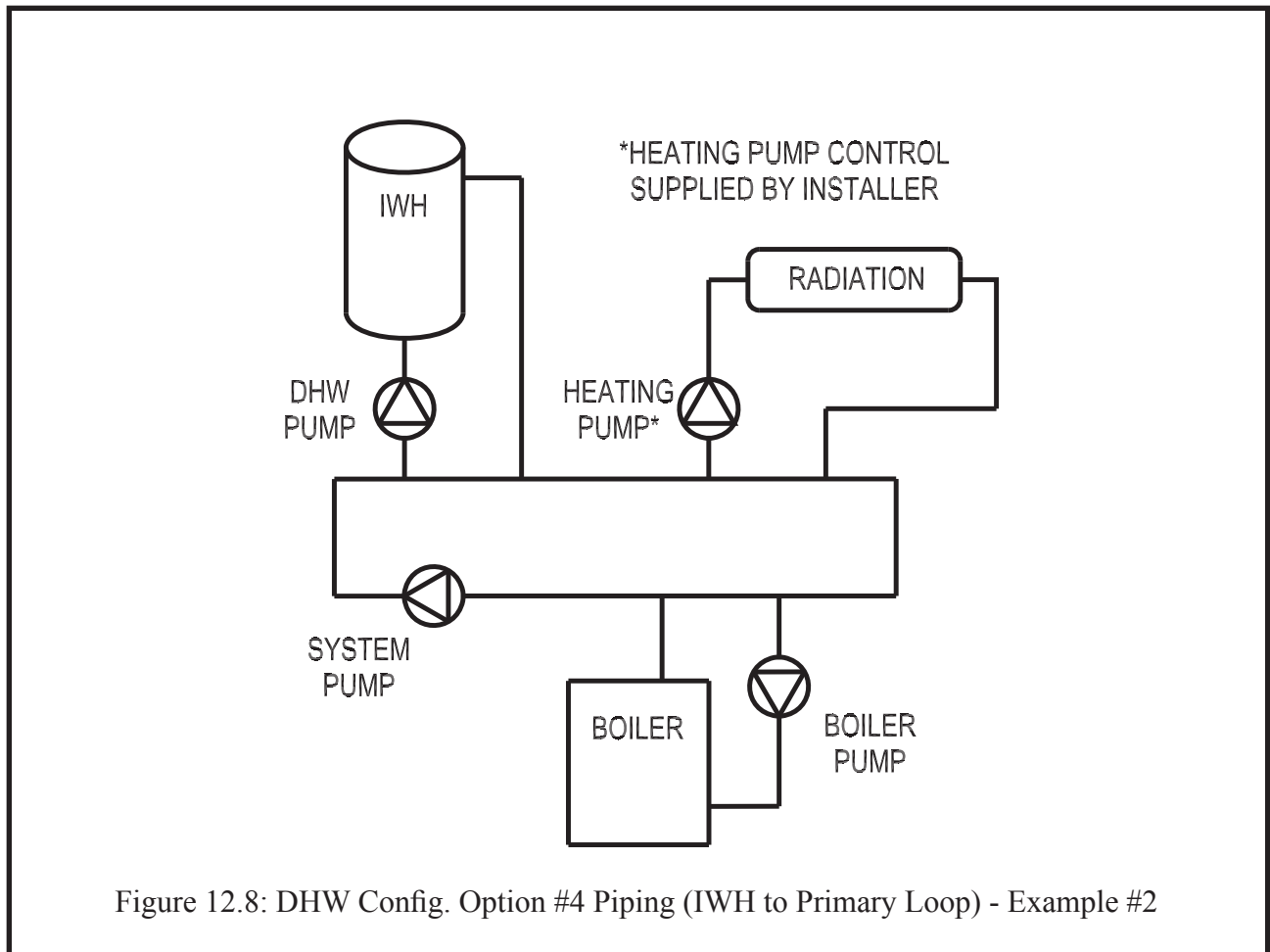

2) CH Settings - Press CH to change the target supply water temperature setting.

a) If outdoor reset is disabled, only one CH setpoint exists. The boiler will always attempt to maintain this temperature during a call for CH. To change the setting, touch the button containing the current setting. Adjust the temperature using the “+” and “-” arrows shown and press SET to save the change (also see “How to Change Settings” in Figure 12.10).

b) If outdoor reset is enabled, there are a total of four settings that can be changed (also see Figures 12.9 and 12.10):

- **Max Supply Setpoint** - This is the maximum permissible supply setpoint temperature, regardless of how low the outdoor temperature is.
- **Min Supply Setpoint** - This is the minimum permissible supply setpoint, regardless of how high the outdoor temperature is.
- **Max Outdoor Temp** - At or above this setting, supply setpoint is equal to the “Min Supply Setpoint”
- **Min Outdoor Temp** - At or below this setting, supply setpoint is equal to the “Max Supply Setpoint”

Pressing the GRAPH button on either the CH Outdoor Reset -1 or CH Outdoor Reset -2 screen allows any of the above four outdoor reset settings to be changed while viewing the other three. This graph is for reference only - it does not scale with changes to the ODR settings.

c) If Warm Weather Shut-Down (WWSD) is enabled, a NEXT button will be present on the CH-Outdoor Reset - 2 screen. This screen allows the user to set the **WWSD Outdoor Temperature**. This is the outdoor temperature above which the boiler will ignore a call for heat from the thermostat.

3) DHW Settings - From the Settings Menu, press the DHW button to change the setpoint temperature when the boiler is responding to a call for DHW:

- If the DHW Configuration selected is for a Bimini Buddy Combi (BB100C), the “DHW Setpoint” is the desired temperature of the DHW (potable hot water) itself.
- If the DHW Configuration selected is for a storage type indirect water heater (such as a Mega-Stor or Maxi-Therm) the “DHW Setpoint” is the setpoint of the boiler supply temperature during a call for DHW. Control of the potable water temperature is accomplished using the thermostat on the storage type indirect water heater.

Note that in *both* of the above cases, the boiler monitors the supply temperature, not the potable water temperature. The difference is that in the case of the BB100C, the control assumes that the potable hot water temperature will be close to that of the boiler supply temperature (a reasonable assumption in the case of the BB100C at most practical flow rates).

4) Manual Input - From the settings menu, press the MANUAL INPUT button to temporarily lock the boiler into either high or low fire (Figure 12.10). This menu is normally used during the performance of combustion tests. Restore automatic operation by pressing the AUTO FIRE Button. If AUTO FIRE is not pressed, the boiler will remain in manual input until one the following occurs:

- 12 minutes and 45 seconds passes with no touch screen activity
- The user returns to the Home Screen

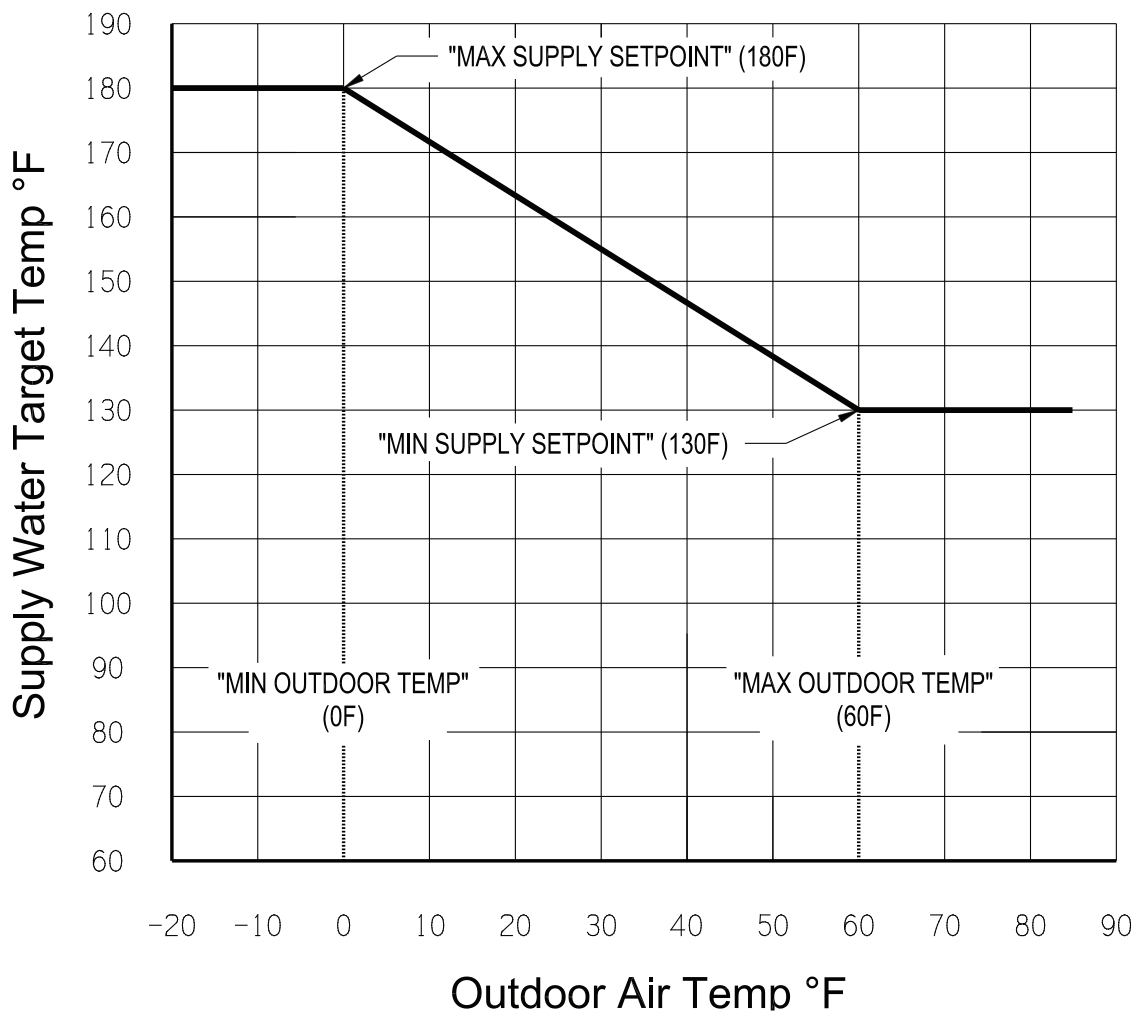

Figure 12.9: Outdoor Reset Curve (Default Settings Shown)

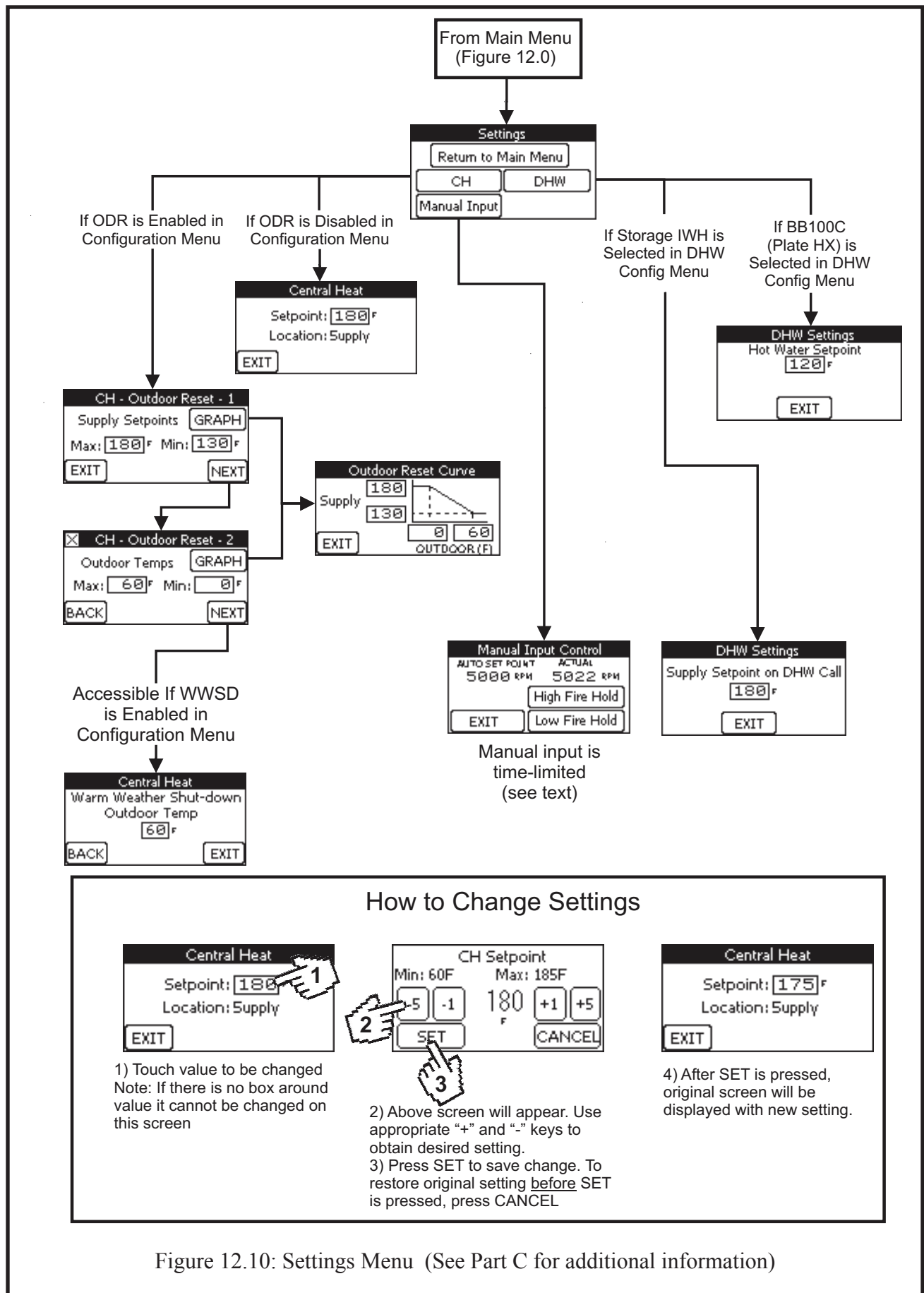

Figure 12.10: Settings Menu (See Part C for additional information)

D. Enter Service Contact Information

If desired, the technician can enter contact information so that the owner knows who to contact for future service. To do this:

- 1) From the Main Menu, press the DIAGNOSTICS button.
- 2) From the Diagnostic Menu, press either the INSTALLER or MORE button (only one will be visible depending on whether you are “logged in”).
 - a) If prompted for a password, use the “+1” key to raise the password to “005”. Press SUBMIT, then NEXT (if you accidentally scroll past 005, press EXIT to return to the main menu and start over).
 - b) Review the Warning and press ACCEPT to continue.
- 3) Press ENTER CONTACT.
- 4) Touch the top blank field to enter the first line. When you do this, the keyboard shown in Figure 12.11 will appear. Use the up and down arrows to access additional characters. After entering the first line, press the return key to temporarily save the line.
- 5) Repeat Step 4 for the remaining two lines.
- 6) Press SET to permanently save all three lines into the memory of the display.

E. Boiler Status Menu

The basic Status Menu is shown in Figure 12.12. It allows the technician to quickly identify how the boiler is currently operating. Specific information available on these screens is as follows:

- 1) Home Screen
 - a) Current Demand - The demand to which the boiler is currently responding. If more than one demand is present, the Current Demands shown will be the one having the highest priority. Typical Current Demands include:
 - **No Demand** - The boiler is not receiving a demand of any type.
 - **Central Heat** - Boiler is receiving a call for space heat
 - **Domestic HW** - Boiler is receiving a call for domestic hot water.
 - **Frost Protection** - The boiler supply, or header temperature fell below 45°F and the boiler is responding to prevent freeze damage to itself.
 - **Off on Warm Weather** - The warm weather shut down option has been selected in the Configuration Menu and the outside air temperature has exceeded the setting at which this function causes the boiler to ignore calls for space heating.
 - **Other Current Demands**, such as “Lead-Lag”, are possible but should never be seen in the applications covered by this manual.
 - b) Active Fault (visible only when there is a problem) - Reverse flashes to indicate certain problems with the boiler or the system. Touching this indicator takes the users to the Diagnostic Menu. See Section XIV for more information.
 - c) Supply - Current boiler supply temperature.

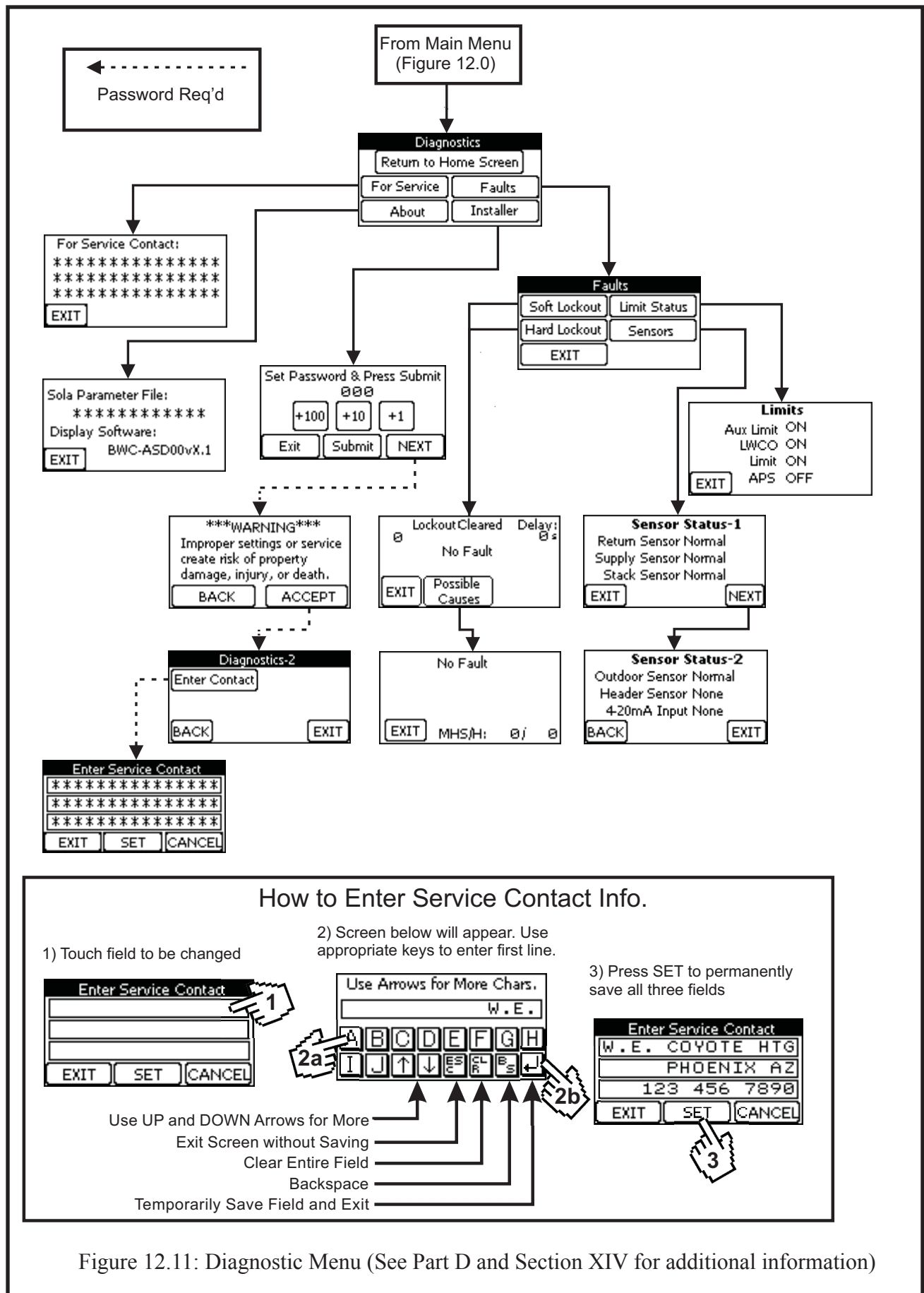

Figure 12.11: Diagnostic Menu (See Part D and Section XIV for additional information)

2) Current Priority Screen:

- a) **Current Demand** - The demand to which the boiler is currently responding. If more than one demand is present, it is the one having the highest priority. See above descriptions under “Home Screen” for specific types of Current Demands.
- b) **Setpoint** - The temperature that the boiler is currently trying to achieve.
- c) **Supply (or Header) Temperature** - The actual water temperature at the current setpoint location (either the boiler supply or header, depending on the demand and what setpoint location was selected in the Configuration Menu).
- d) **Setpoint Source** - Should always read “Local S.P.” in the applications covered by this manual.

3) Boiler Temperatures Screen:

- a) **Supply** - Current water temperature at boiler supply sensor.
- b) **Return** - Current water temperature at boiler return sensor.
- c) **Stack** - Current flue gas temperature near boiler vent connection.
- d) **Header** - Current header sensor temperature. This temperature will only be visible if the header was selected as the setpoint location in the Configuration Menu.

4) Burner Status Screen:

- a) **Burner Status** - Indicates what the burner system is currently doing. Typical Burner Status include:
 - **Standby** - Burner is not needed because there is no call for heat or the target temperature has been reached.
 - **Standby Delay** - Burner is needed, but is being temporarily held off (generally due to a soft lockout - see Diagnostics section).
 - **Safe Start-up** - Control is checking flame circuit before initiating ignition sequence.
 - **Drive Purge** - Waiting for blower to reach pre-purge speed.
 - **Prepurge** - Allowing the blower to clear any residual gas/flue gas from the combustion chamber (10 s).
 - **Drive Light-off** - Waiting for blower to prove that it is at the proper ignition fan speed.
 - **Pre-ignition test** - Test the safety relay and verify that downstream contacts are off.
 - **Pre-ignition** - Energize ignitor with gas valve off to make sure that there is no “false flame” signal.
 - **Direct ignition** - With the ignitor energized, open the gas valve and check for the presence of a flame. Nominal trial for ignition period is 4s.
 - **Running** - Burner is firing.
 - **Post-Purge** - Blower is running after the burner shuts off to clear the combustion chamber of residual gasses. Post purge time is 30s.
 - **Lockout** - Boiler is in a hard lockout (see Diagnostic Section).
- b) **Active Fault** (visible only when there is a problem) - Reverse flashes to indicate a problem with the boiler or the system. Touching this indicator takes the user to the Diagnostic Menu. See Section XIV for more information.
- c) **Hold Delay (Visible only during soft lockout)** - Indicates remaining time before next ignition sequence.
- d) **Flame Signal** - Indicates the strength of the flame signal in DC micro-amps.

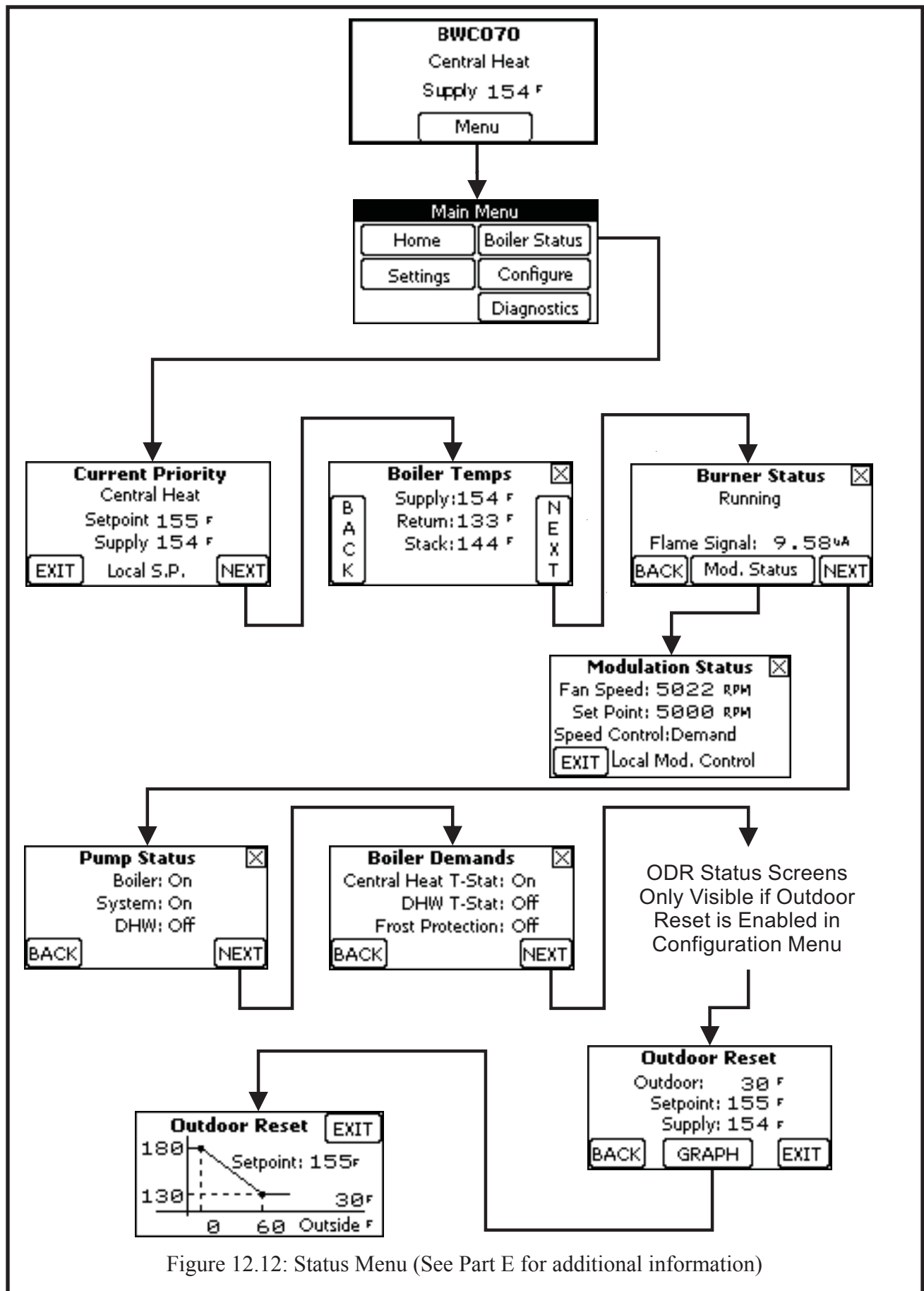

Figure 12.12: Status Menu (See Part E for additional information)

5) Modulation Status Screen:

- a) **Fan Speed** - Current actual fan speed in RPM
- b) **Setpoint** - Current target fan speed in RPM
- c) **Speed Control** - Indicates the function currently controlling fan speed (and therefore firing rate). Typical possibilities include:
 - **Off** - Blower is off.
 - **Burner system** - The blower speed is being determined by that needed for pre-purge, ignition, or post purge.
 - **Demand** - Fan speed is being determined by the “PID” function in the control. This function regulates the fan speed based on a combination of past and present differences between the target water temperature and the actual water temperature.
 - **Supply Limit** - The supply temperature is above 185°F and the input is being limited to reduce the likelihood of high limit activation.
 - **Delta-T limit** - The temperature rise across the boiler has exceeded approximately 54°F and the input is being limited to reduce the likelihood of a soft lockout.
 - **Stack Limit** - The flue temperature is above 200°F and the input is being limited to reduce the likelihood of a hard lockout.
 - **Min Mod** - The input is not allowed to go lower because the minimum allowable fan speed has been reached.
 - **Manual** - The boiler is set in manual input mode (see Settings Menu).
- d) **Modulation Source** - Should always read “Local Mod. Control” in the applications covered by this manual.

6) Pump Status:

- a) **Boiler** - Indicates whether the boiler pump is currently powered.
- b) **System** - Indicates whether the system pump is currently powered.
- c) **DHW** - Indicates whether the DHW pump is currently powered.
- d) **3-Way Valve** - Indicates whether the 3-Way Valve used with a Bimini Buddy is in the CH or DHW position. This indicator is visible only when the BB100C or BB100I is selected in the DHW Configuration Menu. It is shown in place of the DHW pump status in (c).

7) Boiler Demands:

- a) **Central Heat T’Stat** - Indicates whether the boiler is seeing a call for space heat from a thermostat.
- b) **DHW T’Stat** - Indicates whether the boiler is seeing a call from a domestic hot water thermostat.
- c) **B.B. Flow Switch** - Indicates whether the boiler is seeing a call for DHW from a Bimini Buddy Combi (BB100C) flow switch. This indicator is shown in place of the DHW T’Stat status in (b) when the BB100C is selected in the DHW Configuration Menu.
- d) **Frost Protection** - Indicates whether the boiler is seeing a call for frost protection. This demand should never be present unless the boiler supply, or header, temperature is at or below 45°F.

8) Outdoor Reset Screens (only visible when outdoor reset has been enabled in Configuration Menu):

- a) **Outdoor** - Current temperature at outdoor sensor.
- b) **Setpoint** - Current CH setpoint obtained from outdoor reset curve (Figure 12.9).
- c) **Supply (or Header) Temperature** - The actual water temperature at the current setpoint location (either the boiler supply or header, depending on the demand and what setpoint location was selected in the Configuration Menu).
- d) **Outdoor Reset Graph** - Shows all outdoor reset curve settings, the current outdoor temperature, and setpoint. Note: this graph is for reference only and does not scale.

XIII. Service and Maintenance

IMPORTANT

WARRANTY DOES NOT COVER BOILER DAMAGE OR MALFUNCTION IF THE FOLLOWING STEPS ARE NOT PERFORMED AT THE INTERVALS SPECIFIED.

1) Continuously:

- a. Keep the area around the boiler free from combustible materials, gasoline and other flammable vapors and liquids.
- b. Keep the area around the combustion air inlet terminal free from contaminants.
- c. Keep the boiler room ventilation openings open and unobstructed.

2) Monthly Inspections:

- a. Inspect the vent piping and outside air intake piping to verify they are open, unobstructed and free from leakage or deterioration. Call the service technician to make repairs if needed.
- b. Inspect the condensate drain system to verify it is leak tight, open and unobstructed. Call the service technician if the condensate drain system requires maintenance.
- c. Inspect the water and gas lines to verify they are free from leaks. Call the service technician to make repairs if required.

CAUTION

WATER LEAKS CAN CAUSE SEVERE CORROSION DAMAGE TO THE BOILER OR OTHER SYSTEM COMPONENTS. IMMEDIATELY REPAIR ANY LEAKS FOUND.

4) Annual Inspections and Service: In addition to the inspections listed above, the following should be performed by a service technician once every year.

- a. Test the low water cutoff by pressing the “Test” button located at its end. The yellow light should come on and the burner should shut off. If this does not happen, determine why the low water cutoff is not working properly.
- b. Follow the procedure for turning the boiler off found in the BWC Series Lighting and Operating Instructions.
- c. Inspect the wiring to verify the conductors are in good condition and attached securely.

CAUTION

LABEL ALL WIRES PRIOR TO DISCONNECTION WHEN SERVICING CONTROLS. WIRING ERRORS CAN CAUSE IMPROPER AND DANGEROUS OPERATION. VERIFY PROPER OPERATION AFTER SERVICING.

- d. Remove the ignition electrode and inspect it for oxides. Clean the oxides off the electrode with sandpaper. Inspect the ceramic insulator for cracks and replace the ignitor assembly if necessary.
- e. Remove the fan/gas valve assembly from the burner hood. Inspect for lint and dust. If significant lint and dust are found, disassemble the fan/gas valve assembly to expose the swirlplate and fan inlet (see the exploded diagram in the parts list at the back of this manual). Vacuum these parts as required, being careful not to damage the vanes on the swirlplate.
- f. Remove the burner hood to access the burner and the combustion chamber.
- g. Remove the burner and vacuum any dust or lint from the burner. If the burner shows signs of deterioration or corrosion, replace it immediately. Inspect the burner gasket and replace, if necessary.
- h. Inspect the heat exchanger and vacuum any debris found on the pins and other surfaces. Clean the casting pins by flushing with clean water. A soft nylon brush may be used in accessible areas. Drain and flush the inside of the heat exchanger and condensate collector as required. Do not use any cleaning agents or solvents.
- i. Inspect the condensate trap to verify it is open and free from debris. Clean if necessary.
- j. Reinstall the burner, burner hood and fan/gas valve assembly.
- k. Reconnect any wiring which has been disconnected.
- l. Inspect the heating system and correct any other deficiencies prior to restarting the boiler.
- m. Follow Section XI Start-up and Checkout instructions before leaving installation.
- n. Perform the combustion test outlined in Section XI.
- o. Verify that the system PH is between 6.5 and 8.5.
- p. Check for vent terminal obstructions and clean as necessary.

XIV. Troubleshooting

WARNING

Turn off power to boiler before working on wiring.

A. Using the Diagnostics Menu

The plain text display provided with this boiler provides an easy means of identifying most common problems. In the event that the control system detects a problem, such as an open limit or defective sensor, the Active Fault button shown in Figure 14.0 will appear and flash on both the Home Screen and the Burner Status Screen. Touching either Active Fault button will take the user to the Diagnostics Menu. From here, press the flashing button on each successive screen to reach a list of possible causes. In the case of a defective temperature sensor, a defect indicator will also show up on the status screens where the corresponding temperature is normally displayed. See Figure 14.0 for an example of this.

The complete Diagnostics Menu is shown in Figure 12.11. The screens on this menu provide the following information:

- 1) **For Service Contact** - Displays the service contact information entered in Section XII, Step D.
- 2) **About** - Displays the software versions for both the Sola Control and the display
- 3) **Fault Menu** - Provides status of different types of faults by category. When a particular fault exists, the button for that category of faults will flash (see Figure 14.0 for an example of a faulty supply sensor). In the example shown in Figure 14.0, both the Sensor and Soft Lockout buttons flash on the Fault Menu because a defective supply sensor also causes a soft lockout. Fault categories include:
 - a) **Soft Lockout** - A soft lockout prevents the boiler from firing until the problem has been corrected and, in some cases, a specified amount of time (up to 1 hour, depending on the nature of the fault) has passed. An example of the Fault Menu structure during a soft lockout is shown in Figure 14.0
 - b) **Hard Lockout** - A hard lockout prevents the boiler from firing until the problem has been corrected AND the boiler has been manually reset. This can either be done at the Sola itself or on the hard lockout screen. An example of the Fault Menu structure during a hard lockout is shown in Figure 14.2
 - c) **Sensors** - The Sensor Screens show the status of all sensors. Possible states of the sensors include:
 - **None** - The Sola is not looking for an input from this sensor
 - **Normal** - The sensor is working normally
 - **Shorted** - There is a short between the Sola and the sensor or the sensor is defective
 - **Open** - There is a break in the wiring between the Sola and the sensor or the sensor is defective
 - **Out of Range** - The sensor is defective or is being subjected to electrical noise.
 - **Unreliable** - The sensor is defective or is being subjected to electrical noise.

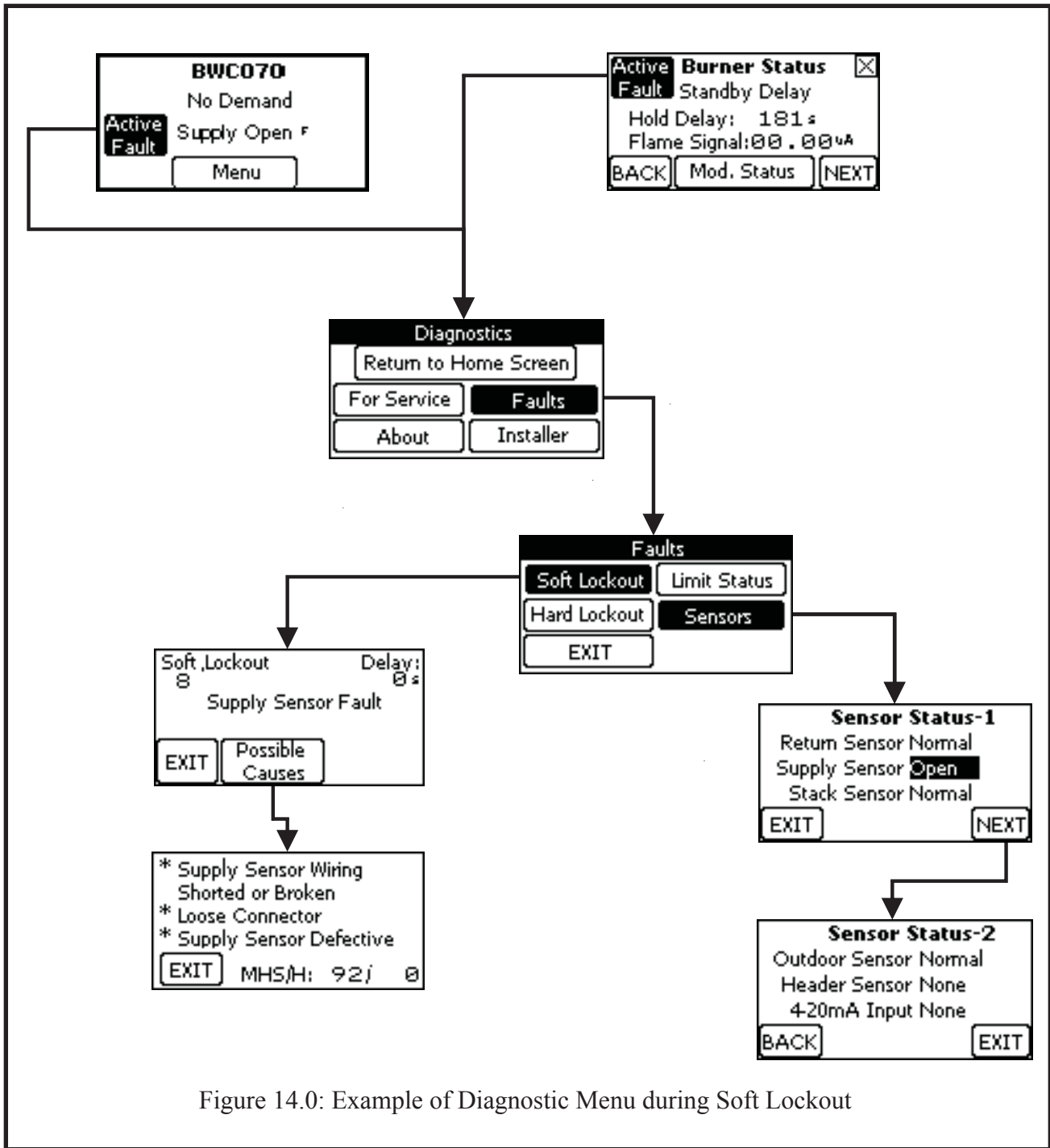

Figure 14.0: Example of Diagnostic Menu during Soft Lockout

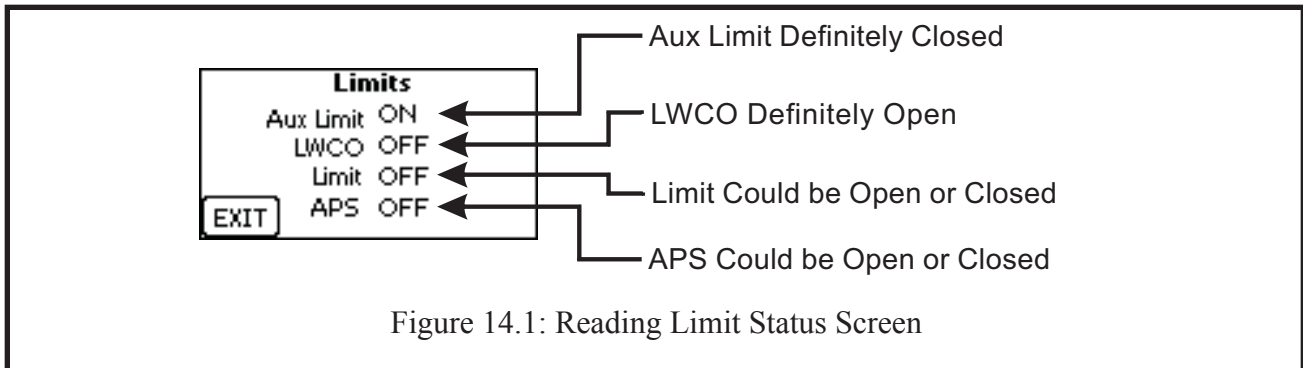

Figure 14.1: Reading Limit Status Screen

d) **Limit Status** - The Limit Status Screen shows the status of all safety limits. Each of these limits is either shown as being ON or OFF. It is important to remember that since all of limits are wired in series, any limit which is in the OFF state will cause all limits “downstream” of it to also appear on this screen as being OFF, regardless of whether or not they actually are. The limits are wired in the following order (also see Figure 10.6):

1. Auxiliary Limit (also the Condensate Float Switch on the BWC151)
2. Low Water Cut-off
3. High Limit
4. Air Pressure Switch

Therefore, in the example shown in Figure 14.1, the Auxiliary limit is known to be closed, the LWCO is known to be open, and the High Limit and Air Pressure switches could be either open or closed.

B. Troubleshooting when the Display is Blank

Use the flow chart in Figure 14.3 to locate the problem when the display is blank or is not readable.

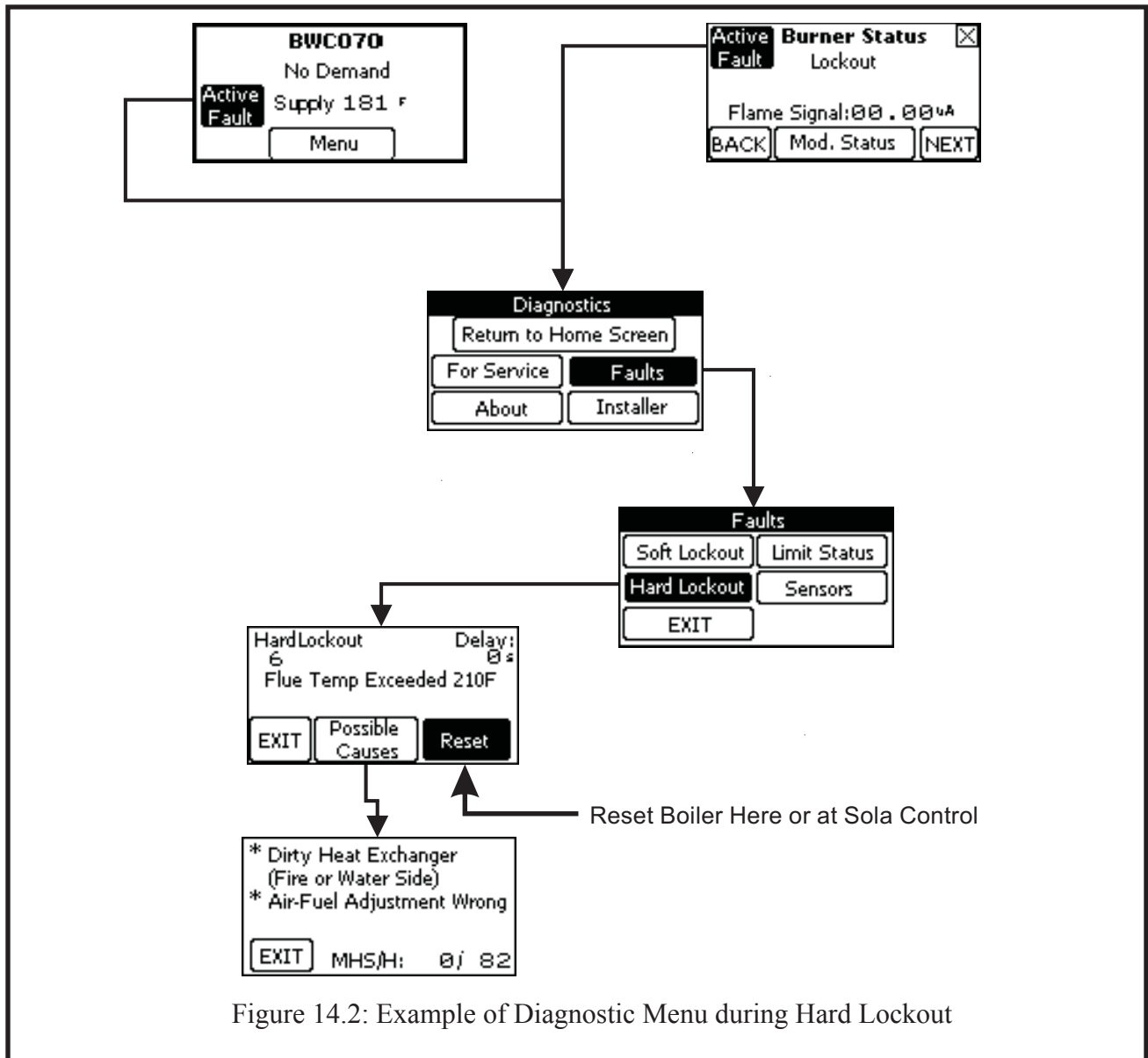

Figure 14.2: Example of Diagnostic Menu during Hard Lockout

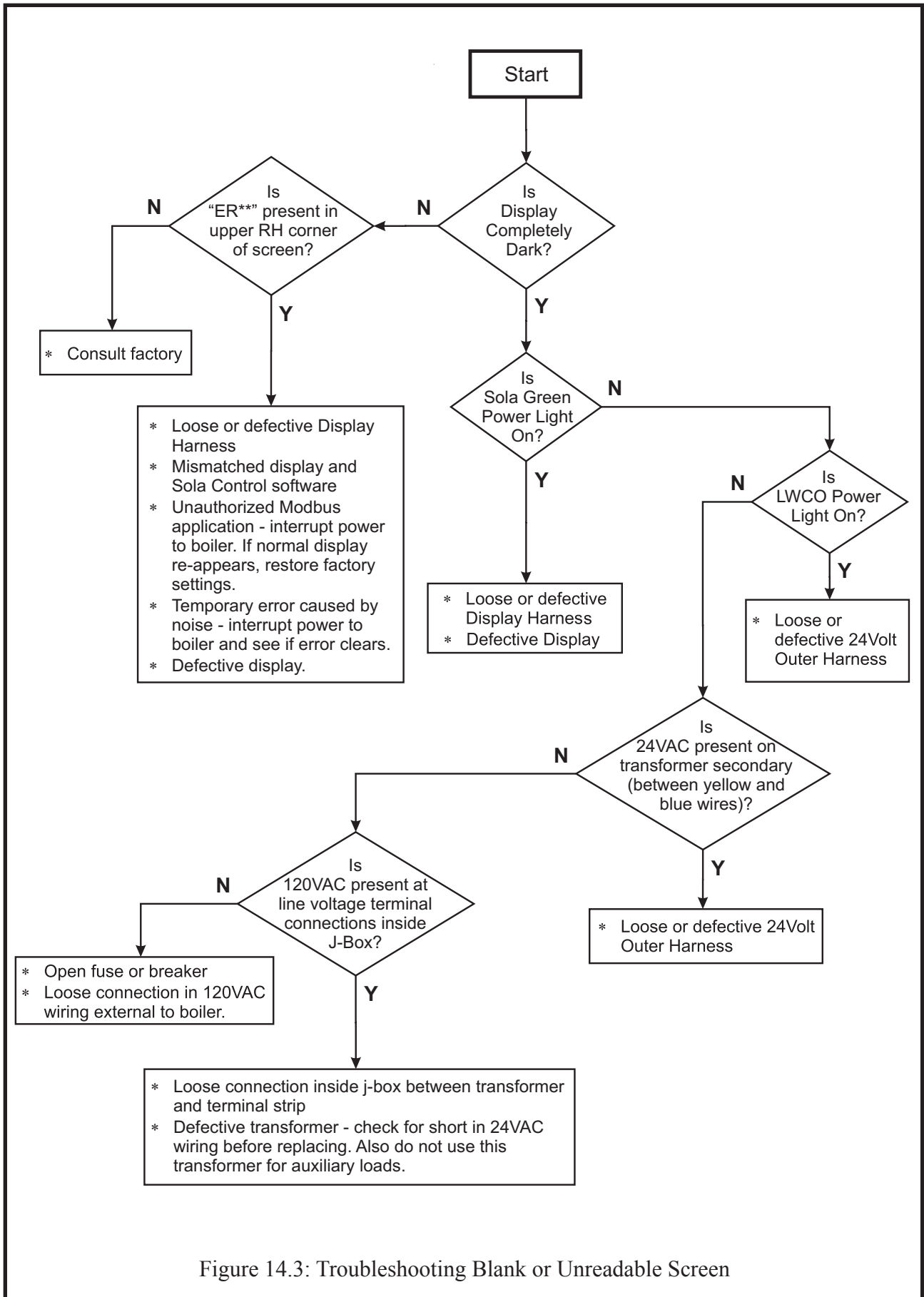

Figure 14.3: Troubleshooting Blank or Unreadable Screen

XV Parts

The following parts may be obtained from any Crown distributor. To find the closest Crown distributor, consult the area Crown representative or the factory at:

Crown Boiler Co.
Customer Service
P.O. Box 14818
Philadelphia, PA 19134
www.crownboiler.com

PARTS LIST

Key	DESCRIPTION	BWC070		BWC090		BWC120		BWC151	
		Part #	QTY	Part #	QTY	Part #	QTY	Part #	QTY
*	Taco 008	950165	1						
*	Taco 0014			950160	1	950160	1	950160	1
*	Gas Cock	950615	1	950615	1	950615	1	950615	1
*	M4 x 30mm Machine Screw (for gas valve harness)	3507342	1	3507342	1	3507342	1	3507342	1
*	Outdoor Sensor	3503622	1	3503622	1	3503622	1	3503622	1
*	Nylon Wire Tie Shoe	960016	9	960016	9	960016	9	960016	9
1	M6 x 16mm Serrated Flange Head Hex Screw	900722	4	900722	4	900722	4	900722	4
2	AM Heat Exchanger Bracket	230413	1	230413	1	230414	1	230414	1
3	Heat Exchanger	230013	1	230013	1	230014	1	230015	1
4	Sump Gasket	230713	1	230713	1	230714	1	230716	1
5	80mm Vent Gasket	240039	1	240039	1	240039	1	240039	1
6	Sump	230703	1	230703	1	230704	1	230706A	1
7	M6 Washer	230906	4	230906	4	230906	4	230906	4
8	M6 x 30mm Cap Screw	230935	4	230935	4	230935	4	230935	8
9	Condensate Trap Gasket	240005	1	240005	1	240005	1	240005	1
10	Condensate Trap, 150mm	240955	1	240955	1	240955	1	240955	1
11	Red Vinyl Cap	240990	1	240990	1	240990	1	240990	1
12	Supply Temperature Sensor	230122	1	230122	1	230122	1	230122	1
13	3/4 BSP x 1 1/2" Steel Nipple	950140	2	950140	2	950140	2		
13	1" BSP x 1 1/2" Steel Nipple							950141	2
14	Supply/Return Fitting	230095	2	230095	2	230095	2	230096	2
15	Gauge Sensor Well	230102	1	230102	1	230102	1	230102	1
16	Gauge Cap Tube Clamp	230103	1	230103	1	230103	1	230103	1
17	High Limit	960124	1	960124	1	960124	1	960124	1
18	Burner	230035	1	230035	1	230045	1	230046	1
19	Burner Hood Gasket	230032	1	230032	1	230032	1	230032	1
20	5 x 8 Grooved Pin	230945	2	230945	2	230945	2	230945	2
21	Burner Hood, AM	230030	1	230030	1	230030	1	230030	1
22	Burner Hood Cover Plate Gasket	230050	1	230050	1	230050	1	230050	1
23	Burner Hood Cover Plate	230051	1	230051	1	230051	1	230051	1
24	M4 X 8 Machine Screw	230923	3	230923	3	230923	3	230923	3
25	M6 x 40mm Set Screw	230940	4	230940	4	230940	4	230940	4
26	M6 Nut With Captive Washer	240905	4	240905	4	240905	4	240905	4
27	M4 x 20mm Set Screw	240920	2	240920	2	240920	2	240920	2
28	Electrode Gasket	240011	1	240011	1	240011	1	240011	1
29	Electrode	240010	1	240010	1	240010	1	240010	1
31	M4 Shoulder Nut	240921	2	240921	2	240921	2	240921	2
33	M5 x 30mm Set Screw	230930	4	230930	4	230930	4	230930	4
34	M4 x 12mm PH Machine Screw	240925	2	240925	2	240925	2	240925	2
35	Sight Glass Holder	240951	1	240951	1	240951	1	240951	1
36	Sight Glass Gasket	240952	2	240952	2	240952	2	240952	2
37	Sight Glass	240950	1	240950	1	240950	1	240950	1
38	3/4 x Cl Blk Nipple	95-105	2	95-105	2	95-105	2	95-105	1
39	3/4 x Cl. Brass Nipple	950135	1	950135	1	950135	1		
40	Gauge Pressure Fitting	230101	1	230101	1	230101	1	230101	1
41	Return Temperature Sensor	230125	1	230125	1	230125	1	230125	1
42	Gauge	230100	1	230100	1	230100	1	230100	1
43	1" ID x 1" NPT CSST Adaptor	230710	2	230710	2	230710	2	230710	2
44	1" Gray Coated CSST, Nut by Nut	230700	1	230700	1	230700	1	230709	1
45	3/4 x 1 Blk Reducing Elbow	950116	1	950116	1	950116	1		
45	1" Blk Elbow							950190	1
46	1/2" Yellow Coated CSST, Nut by Nut	230705	1	230705	1	230705	1	230707	1
47	5/8" OD x 1/2" MPT CSST Adaptor	230715	2	230715	2	230715	2	230715	2

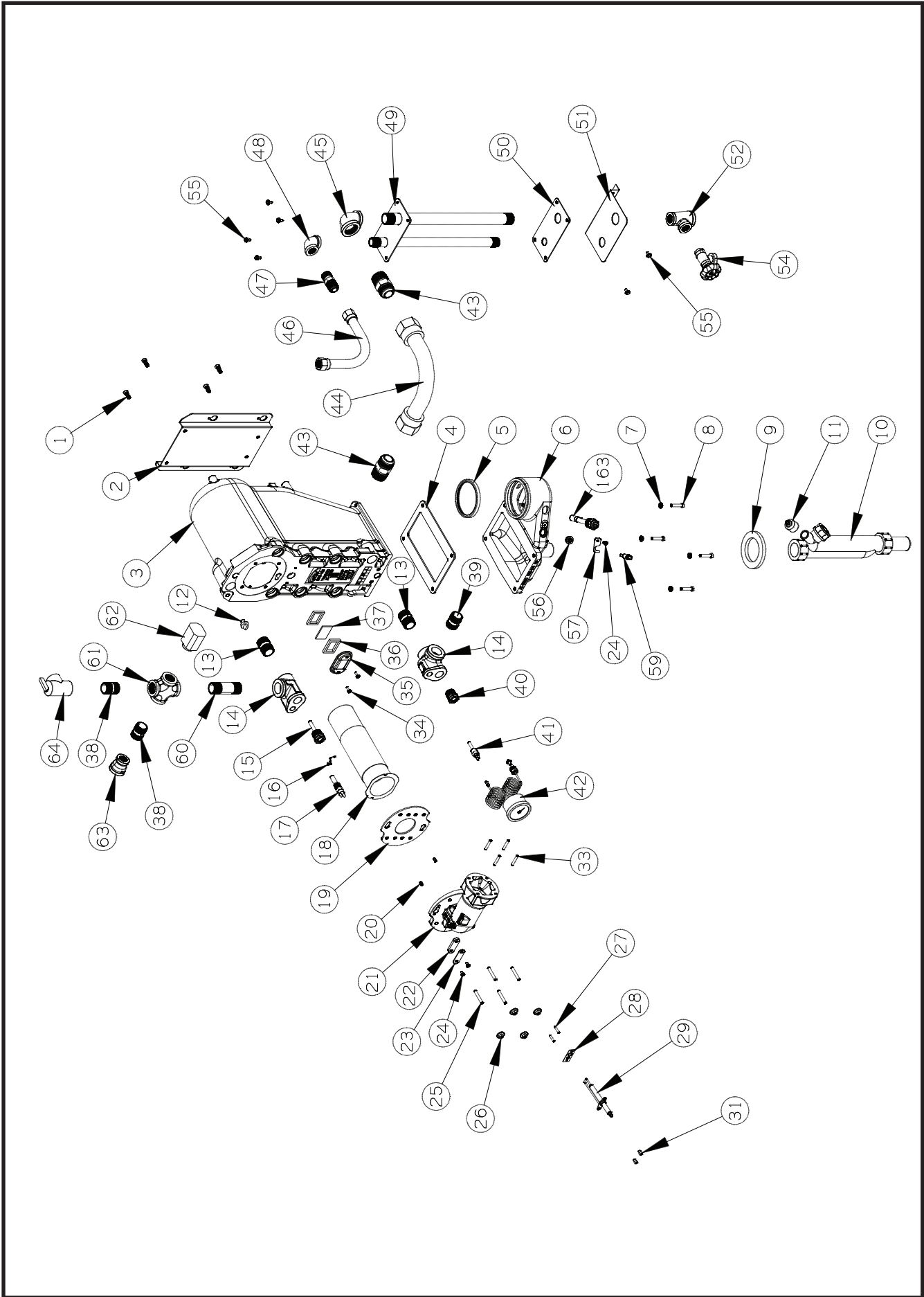

PARTS LIST

Key	DESCRIPTION	BWC070		BWC090		BWC120		BWC151	
		Part #	QTY	Part #	QTY	Part #	QTY	Part #	QTY
48	1/2" Blk Elbow	950049	1	950049	1	950049	1	950049	1
49	Flanged Nipple Assy	950700	1	950700	1	950700	1	950701	1
50	Flanged Nipple Gasket	230401	1	230401	1	230401	1	230405	1
51	Pipe Support Bracket	230470	1	230470	1	230470	1	230480	1
52	3/4 x 1 x 3/4 Reducing Black Tee	950118	1	950118	1	950118	1		
52	1 x 1 x 3/4 Black Tee							950212	1
54	3/4 Boiler Drain	95-041	1	95-041	1	95-041	1	95-041	1
55	#10 x 1/2 Sheet Metal Screw	90-212	36	90-212	36	90-212	36	90-212	36
56	Fluegas Sensor Grommet	230056	1	230056	1	230056	1	230056	1
57	Fluegas NTC Mounting Plate	230055	1	230055	1	230055	1	230055	1
59	Fluegas Temperature Sensor	230120	1	230120	1	230120	1	230120	1
60	3/4 x 3" Nipple	95-027	1	95-027	1	95-027	1		
60	1 x 3" Nipple							950104	1
61	3/4 Black Cross	950130	1	950130	1	950130	1		
61	1" Black Cross							950105	1
62	Hydrolevel #1100 LWCO	450600	1	450600	1	450600	1	450600	1
63	3/4 x 1 Black Reducing Coupling	950120	1	950120	1	950120	1		
64	30 psi Relief Valve	95-040	1	95-040	1	95-040	1	95-040	1
65	Blower Gasket	240001	1	240001	1	240001	1	240001	1
66	Blower, RG128/1300-3612	230002	1	230002	1	230002	1	230002	1
67	M5 Locknut	900003	4	900003	4	900003	4	900003	4
68	3 x 63mm Buna-N O-Ring	230003	1	230003	1	230003	1	230003	1
69	Fan Inlet block	230150	1	230150	1	230150	1	230150	1
70	10-32 x 1/8 ID Hose Barb	90-222	1	90-222	1	90-222	1	90-222	1
71	1/8 ID Silicone Tubing (12")	14-008	1	14-008	1	14-008	1	14-008	1
72	Dungs Air Inlet Adaptor Part 2 (male)	3507345	1	3507345	1	3507345	1	3507345	1
73	42.5mm Short Fan Adaptor Plate	3507346	1	3507346	1	3507346	1	3507346	1
74	M4 x 25mm Flat Head Machine Screw	900010	3	900010	3	900010	3	900010	3
75	5mm Swirlplate (Blue)	3507337	1	3507337	1				
75	9mm Swirlplate (Red)					3507347	1		
75	12mm Swirlplate (Gray)							3507336	1
76	Dungs Air Inlet Adaptor Part 1 (female)	3507344	1	3507344	1	3507344	1	3507344	1
77	M4 x 10mm FH Machine Screw	900006	4	900006	4	900006	4	900006	4
78	Injector Plate	3507348	1	3507348	1	3507348	1	3507348	1
79	M4 x 25mm Positdrive Hd Screws	900734	3	900734	3	900734	3	900734	3
80	1.5 x 17mm O-Ring	3507349	1	3507349	1	3507349	1	3507349	1
81	7.0mm Orifice					3507339	1	3507339	1
81	5.0mm Orifice	3507338	1	3507338	1				
82	GB-WND 055 Head On Gas Valve	3507340	1	3507340	1	3507340	1	3507340	1
83	6-32 x 1/2 HWH type F Self Tapping Screw	900713	6	900713	6	900713	6	900713	6
84	Pressure Switch	230009	1	230009	1	230009	1	230009	1
85	Pressure Switch Bracket	230475	1	230475	1	230475	1	230475	1
86	M4 x 6mm Round Head Machine Screw	900011	2	900011	2	900011	2	900011	2
87	Concentric Vent Collar	230501	1	230501	1	230501	1	230501	1
88	Vent Kit	230500	1	230500	1	230500	1	230580	1
89	Control Box	230332	1	230332	1	230332	1	230332	1
90	Gauge Bracket	950705	1	950705	1	950705	1	950705	1
91	Line Voltage Terminal Strip Bracket	230334	1	230334	1	230334	1	230334	1
92	AT140 Transformer	35-2000	1	35-2000	1	35-2000	1	35-2000	1
93	J-Box	230335	1	230335	1	230335	1	230335	1
94	J-Box Cover	230336	1	230336	1	230336	1	230336	1
95	10-32 x 3/8" Ground Screw	146-95-301	2	146-95-301	2	146-95-301	2	146-95-301	2
96	10mm x 9 Pole Euro Terminal Strip	960098	2	960098	2	960098	2	960098	2
97	8mm x 9 Pole Euro Terminal Strip	960097	1	960097	1	960097	1	960097	1
98A	4-40 x 3/4 RH Machine Screw	900475	6	900475	6	900475	6	900475	6
*98B	4-40 ZP Hex Nut	900476	6	900476	6	900476	6	900476	6
99	Sola Boiler Control (Programmed)	3523120S	1	3523120S	1	3523120S	1	3523120S	1
100	Low Voltage Terminal Strip Bracket	230333	2	230333	2	230333	2	230333	2
101	Display Mounting Bracket	230337	1	230337	1	230337	1	230337	1
102	Panasonic GT01 Display (Programmed)	3511605	1	3511605	1	3511605	1	3511605	1

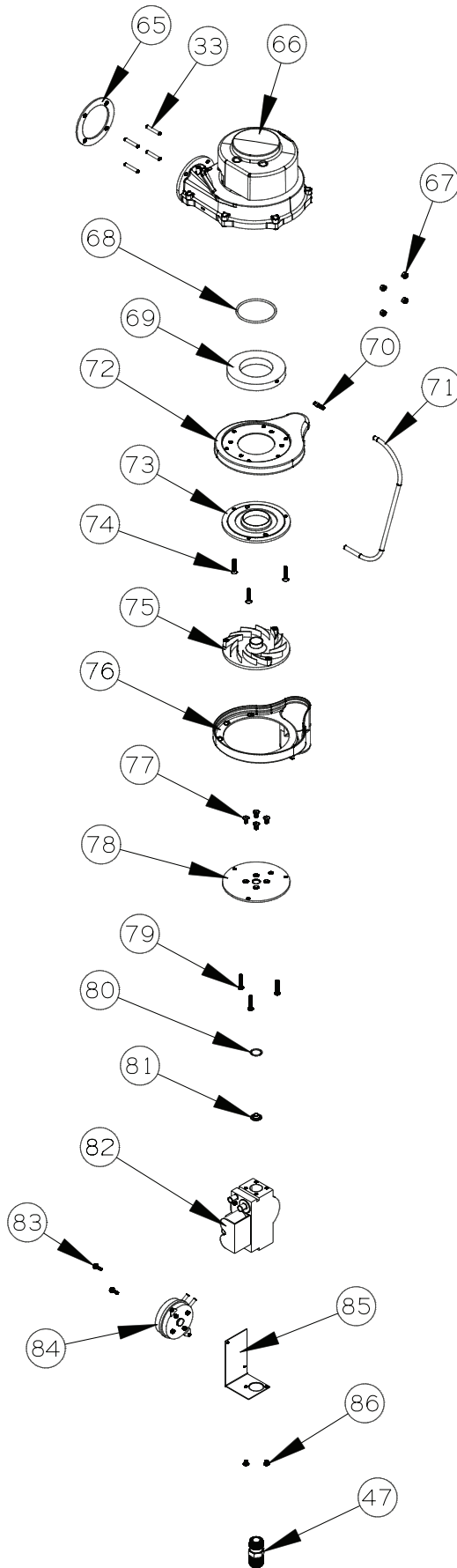

PARTS LIST

Key	DESCRIPTION	BWC070		BWC090		BWC120		BWC151	
		Part #	QTY	Part #	QTY	Part #	QTY	Part #	QTY
103	Tinnerman Nut	90-217	2	90-217	2	90-217	2	90-217	2
105	1/8 x 2-1/2" Cotter Pin	900485	1	900485	1	900485	1	900485	1
106	10-16 x 1/2" Thread Forming Screw	900725	12	900725	12	900725	12	900725	12
110	Condensate Pump Receptacle	960023	1	960023	1	960023	1	960023	1
111	Escutcheon Plate	230380	1	230380	1	230380	1	230385	1
112	#8 Self Drilling Screw	900055	3	900055	3	900055	3	900055	3
114	Rear Panel	230303	1	230303	1	230303	1	230303	1
115	#10 x 1/2 Truss Hd Screws	900120	12	900120	12	900120	12	900120	12
116	1/8" Aluminum Pop Rivet	90-068	8	90-068	8	90-068	8	90-068	8
117	Draw Latch	230202	2	230202	2	230202	2	230202	2
119	Top Panel	230323	1	230323	1	230323	1	230325	1
120	Vent Stub	230502	1	230502	1	230502	1	230502	1
121	Wall Hook	230410	1	230410	1	230410	1	230410	1
122	5/16" Flat Washer	900102	2	900102	2	900102	2	900102	2
123	5/16" x 2" Lag Screw	900726	2	900726	2	900726	2	900726	2
124	1/4-20 x 1/2 Phillips Pan Hd with Ext Washer	900720	8	900720	8	900720	8	900720	8
125	Boiler Hanging Bracket	230435	1	230435	1	230435	1	230435	1
126	1/4-20 Nylon Insert Lock Nut	900721	4	900721	4	900721	4	900721	4
127	LH Side Panel	230301	1	230301	1	230301	1	2303015	1
128	RH Side Panel	230300	1	230300	1	230300	1	2303005	1
129	8" Long Bead Chain Lanyard	230210	2	230210	2	230210	2	230210	2
130	6-32 x 1/2 HWH Type F Self Tapping Screw	900713	4	900713	4	900713	4	900713	4
131	6-32 Wing Nut	900724	4	900724	4	900724	4	900724	4
132	Rubber Bumper	230905	2	230905	2	230905	2	230905	2
133	Pinhole Grommet	10-026	2	10-026	2	10-026	2	10-026	2
134	Draw Keeper	230204	2	230204	2	230204	2	230204	2
135	Bottom Panel	230343	1	230343	1	230343	1	230345	1
136	Bottom Pan Support Bracket	230395	1	230395	1	230395	1	230395	1
137	AM Door Gasket	230400	1	230400	1	230400	1	230400	1
138	Upper Front Jacket Panel	230353	1	230353	1	230353	1	230353	1
139	Crown Aluminum Nameplate	98-004	1	98-004	1	98-004	1	98-004	1
142	Nylon Spacer, #10 x 0.125	230212	2	230212	2	230212	2	230212	2
143	3/16 x 1/2 Slic Pin	230200	2	230200	2	230200	2	230200	2
144	Lower Front Jacket Panel	230363	1	230363	1	230363	1	230363	1
145	Heyco 2" Window	900723	1	900723	1	900723	1	900723	1
146	Latch CM Cam	230206	2	230206	2	230206	2	230206	2
147	Straight Cam	230208	2	230208	2	230208	2	230208	2
150	24 Volt Outer Harness	9601700	1	9601700	1	9601700	1	9601700	1
151	High Temperature Circulator Harness	9601705	1	9601705	1	9601705	1	9601705	1
152	Line Voltage Blower Harness	9602309	1	9602309	1	9602309	1	9602309	1
153	Low Temperature Circulator Harness	9601710	1	9601710	1	9601710	1	9601710	1
154	DHW Thermostat Harness	9601715	1	9601715	1	9601715	1	9601715	1
155	Outdoor Sensor Harness	9601720	1	9601720	1	9601720	1	9601720	1
156	Neutral Harness	9601725	1	9601725	1	9601725	1	9601725	1
157	J-Box Ground Harness	9601735	1	9601735	1	9601735	1	9601735	1
158	Dungs AC Gas Valve Harness	9601740	1	9601740	1	9601740	1	9601740	1
159	Ignition Cable Harness	9601745	1	9601745	1	9601745	1	9601745	1
160	J1 Harness	9601750	1	9601750	1	9601750	1	9601750	1
161	Fan Control Harness	9601755	1	9601755	1	9601755	1	9601755	1
162	Limit String Harness	9601760	1	9601760	1	9601760	1		
163	Float Switch							240060	1
164	Heat Exchanger Support Bracket							230420	1
165	M6 x 12 Machine Screw							900015	2
166	1/4-20 x 3/4 Cap Screw							90-213	2
167	1/4-20 Nut							90-202	2
168	Low Temperature Thermostat Harness	9601765	1	9601765	1	9601765	1	9601765	1
169	Limit String Harness with Float Switch							9601770	1
170	Display Harness	9601775	1	9601775	1	9601775	1	9601775	1
171	J-Box Auxillary Jumper	9601780	1	9601780	1	9601780	1	9601780	1
172	Alarm Harness	9601785	1	9601785	1	9601785	1	9601785	1
173	Sensor Harness	9601790	1	9601790	1	9601790	1	9601790	1
174	Blower Power Harness (Inner)	9601795	1	9601795	1	9601795	1	9601795	1

* NOT SHOWN

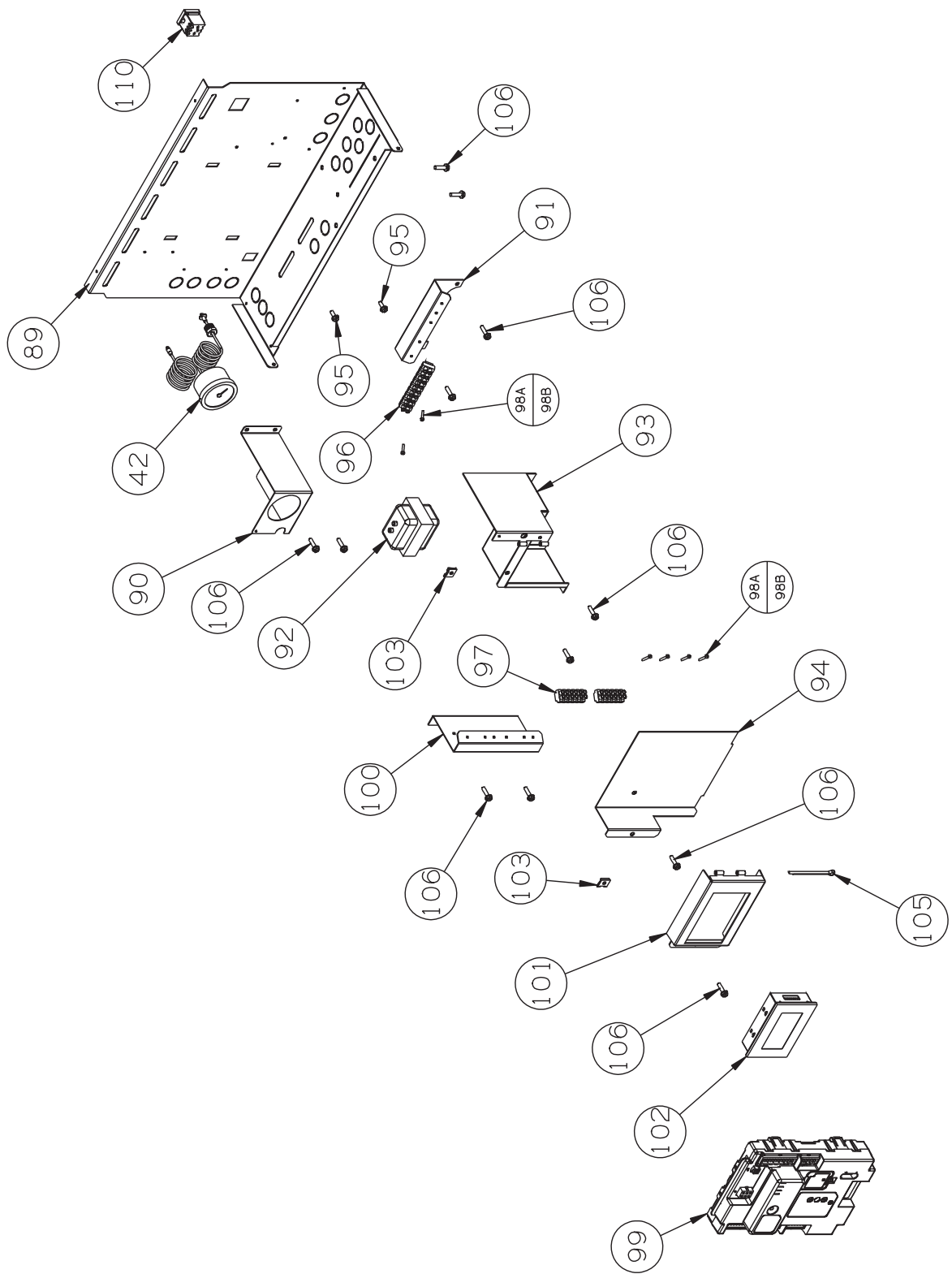

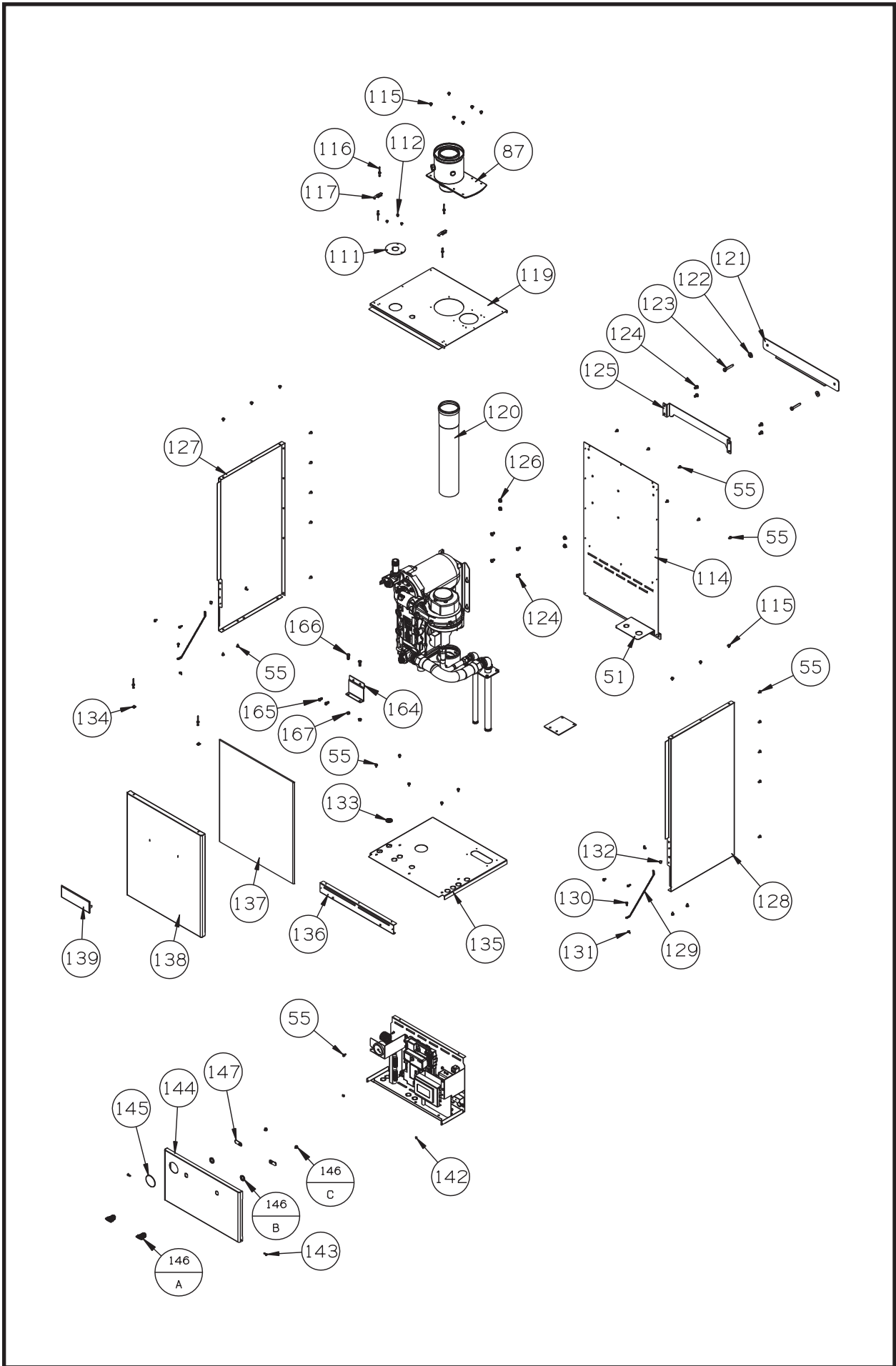

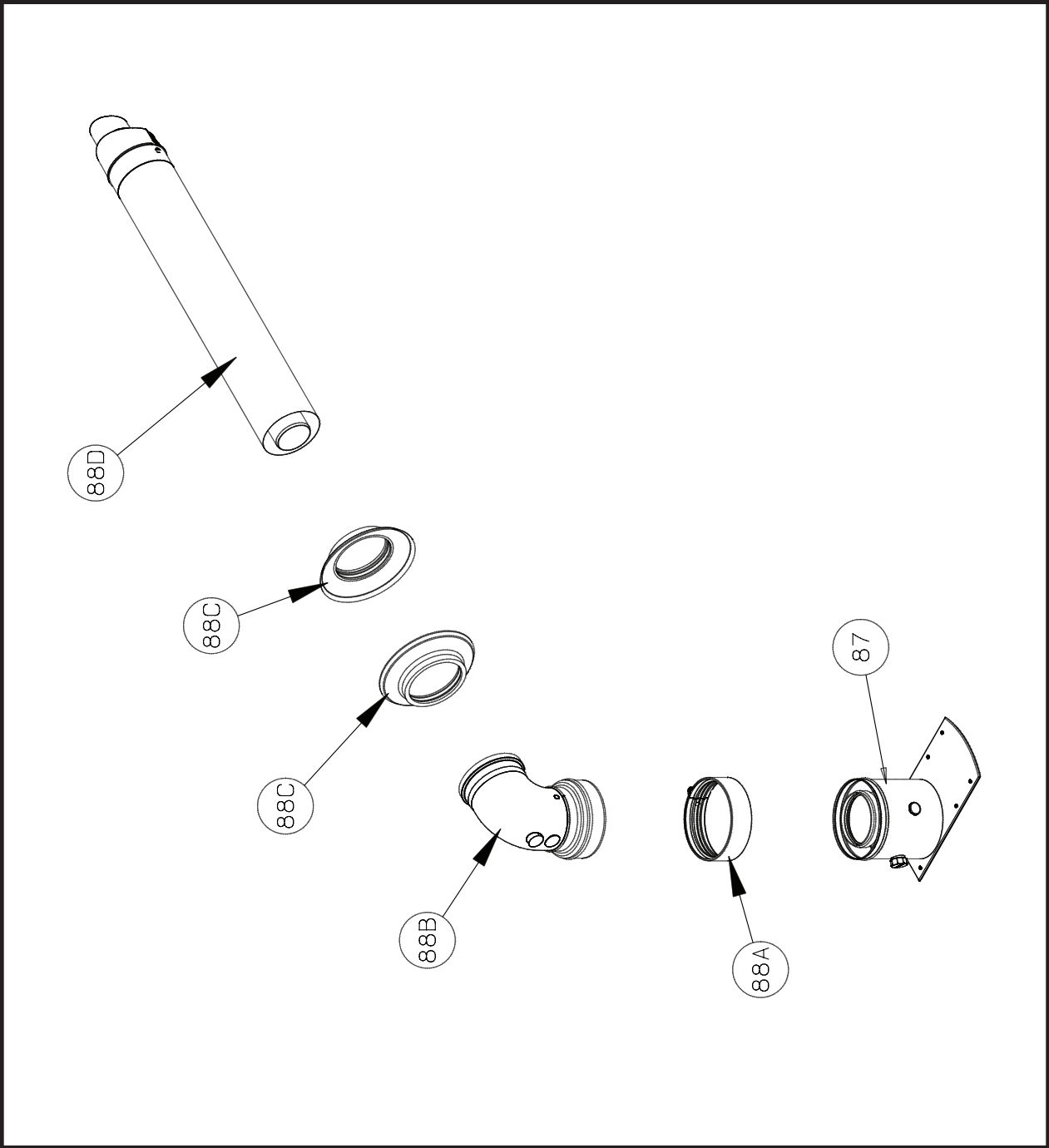

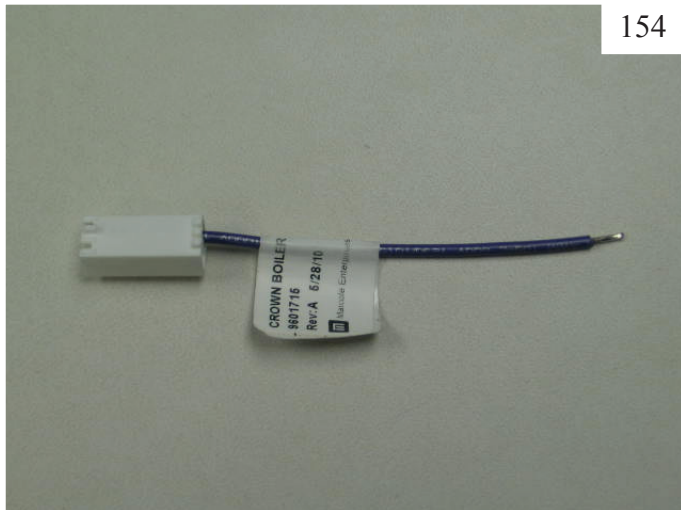
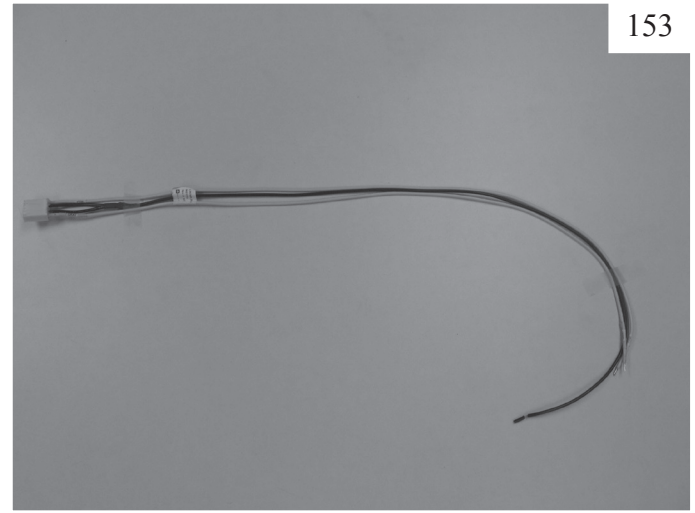
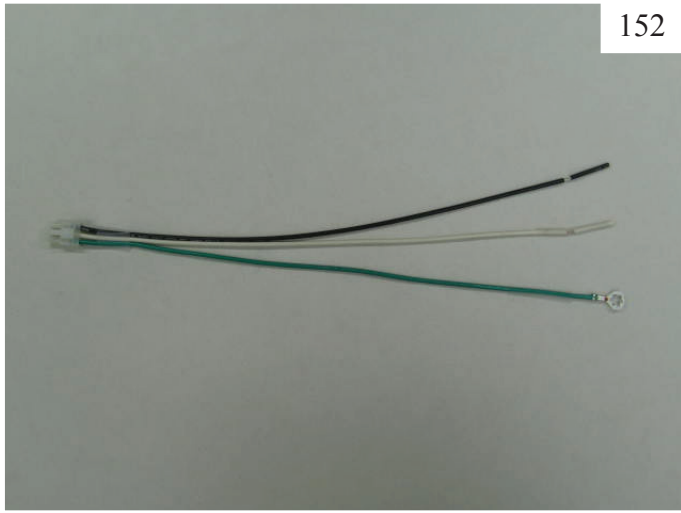
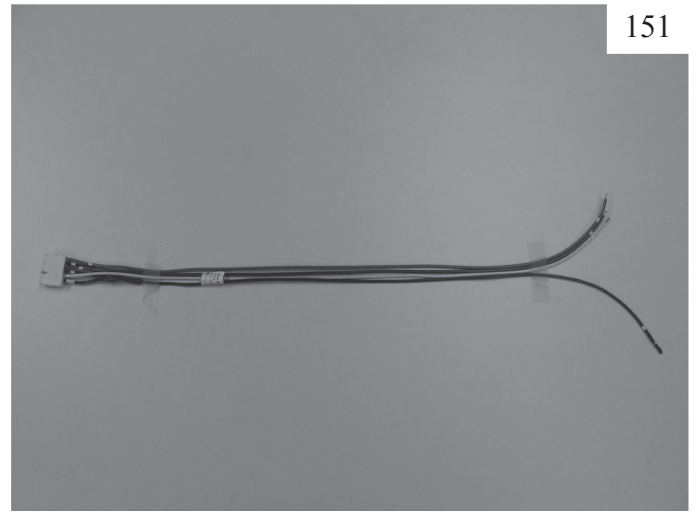
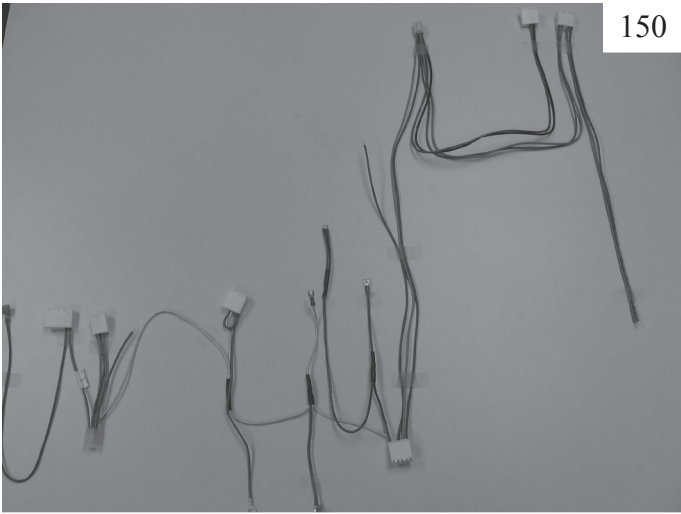

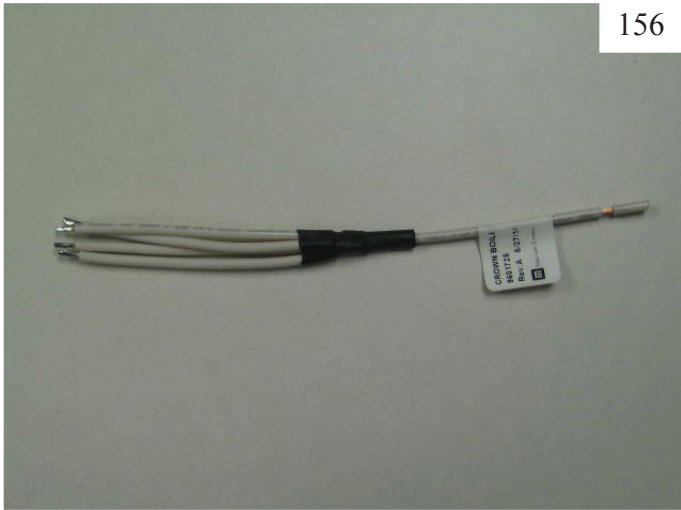

156



157



158



159

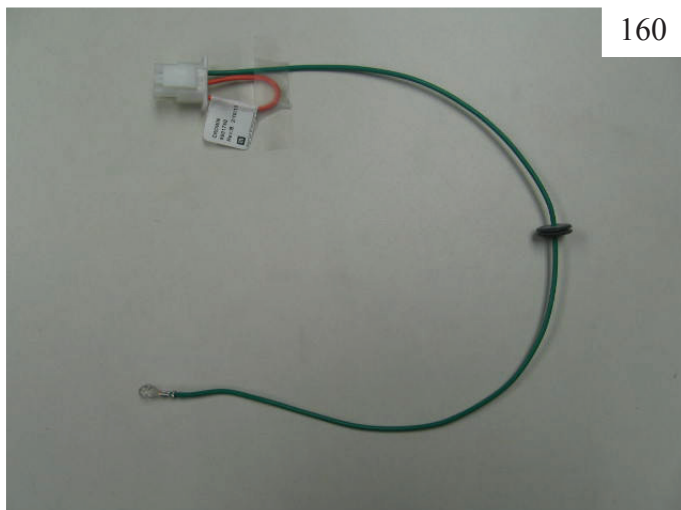

160



161

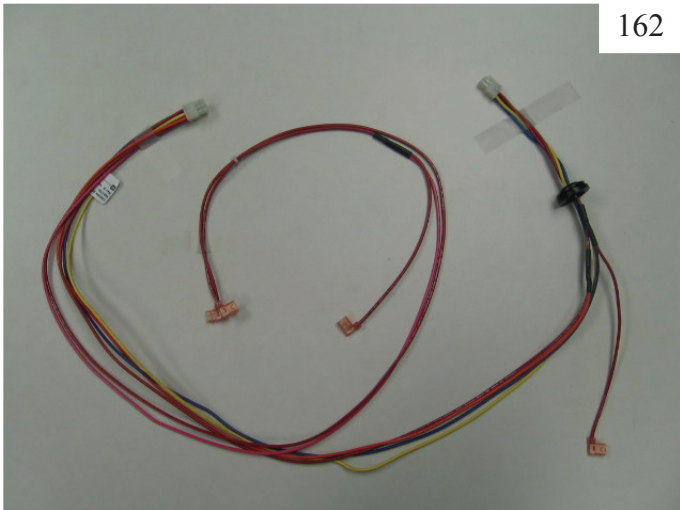

162

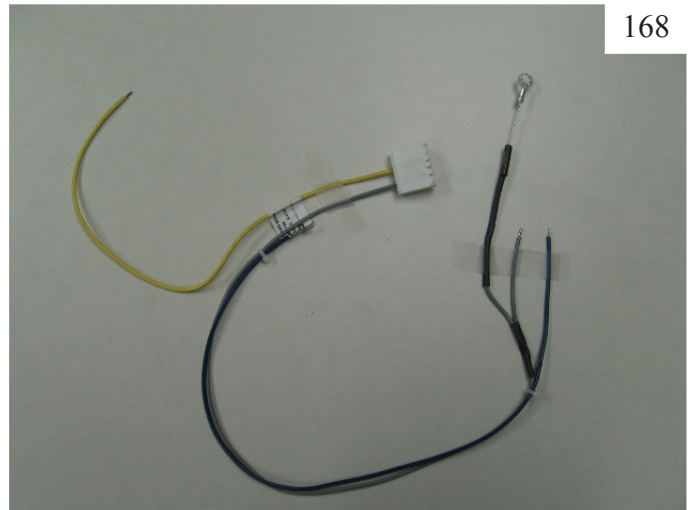

168

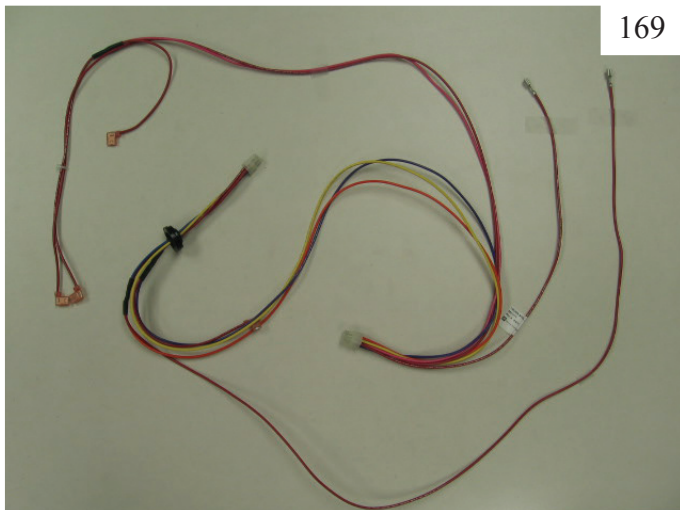

169

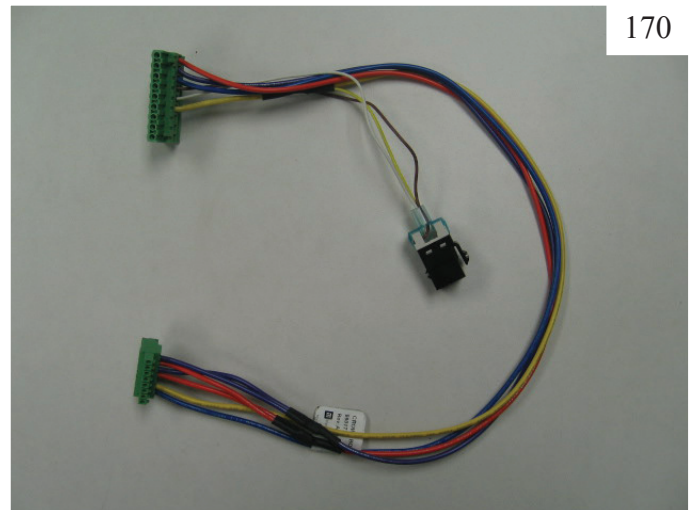

170



171

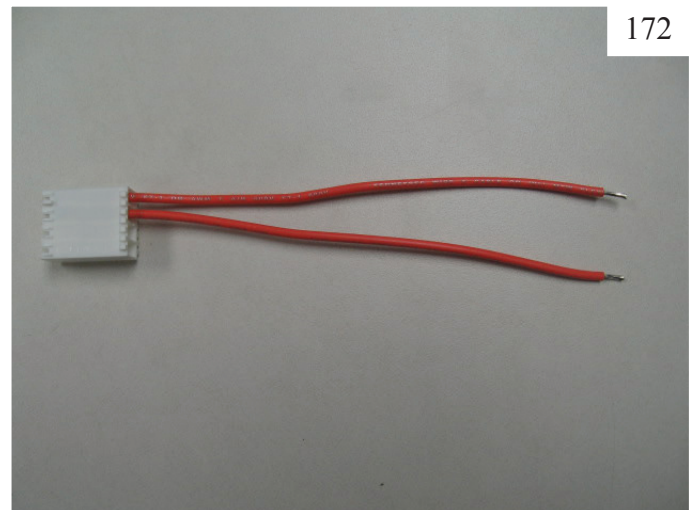

172

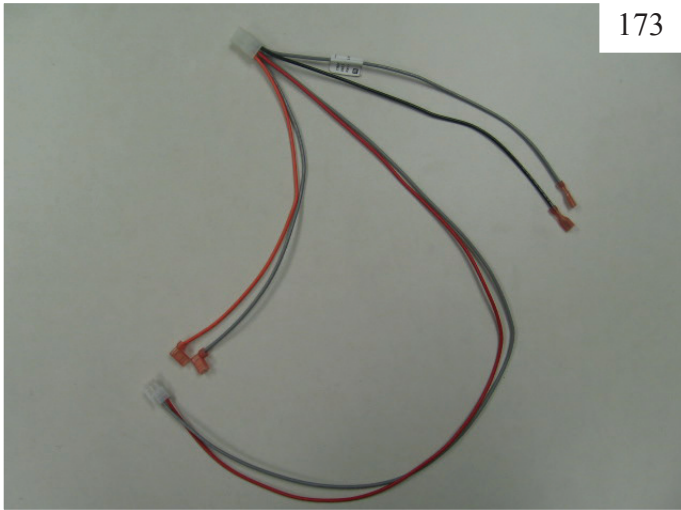

APPENDIX A

Optional Method for Retrofitting BWC Boilers into Existing Circulator Zone Systems

The piping/wiring method shown in this Appendix is sometimes useful in retrofit applications where the old boiler was installed with circulator zones. The piping shown in this Appendix may offer the advantage of fewer changes to existing piping. In addition, if one of the original zones was used for an indirect water heater, the piping in this Appendix may allow the original indirect water heater circulator to be reused.

To use this piping/wiring method, observe the following guidelines:

- 1) In this manual, the “boiler loop” is defined as the piping running directly from the boiler supply to the boiler return. The boiler loop pipe size, maximum equivalent length, and circulator size are determined using Table 9.5 as described in Section IX. Note that the pipe size shown in Table 9.5, column (a) is the minimum allowable size; larger pipe and fittings can be placed in the boiler loop as long as there are no size transitions near the “closely spaced tees” (see 2 below).
- 2) Connect the original zone manifolds into the two closely spaced tees as shown in Figure A.1. These two tees must be no more than 12” apart. At least 8 diameters of straight pipe must be installed upstream of the upper (supply) tee and at least 4 diameters downstream of the lower (return) tee. If the original zone manifold piping is larger than the boiler loop piping, best results will be achieved by making all boiler loop piping between the closely spaced tees, and for at least 8 diameters upstream and 4 diameters downstream, equal to the larger size. For example, if the boiler loop piping is 1” and the original zone manifolds are 1-1/4”, the boiler loop piping between the tees should be 1-1/4”, along with at least 10” of straight pipe upstream and 5” of straight pipe downstream of the two tees.
- 3) In the example shown in Figure A.1 where Zone 2 is used for an indirect water heater:
 - a) Connect the Boiler Loop Circulator to the “Boiler Pump” terminals on the boiler.
 - b) Connect the Zone 1 Circulator to the “System Pump” terminals on the boiler.
 - c) Connect the Zone 2 Circulator to the “DHW Pump” terminals on the boiler.
 - d) Connect the DHW thermostat and CH thermostat to the corresponding low voltage terminals on the boiler.
 - e) In the DHW Configuration Menu, select “DHW Circulator Pumps to Primary Loop” under DHW options.
 - f) In the System Pump Configuration Menu, select either “System Runs for CH” or “System Pump runs for CH, Off for DHW Priority”.

See Section X and XII for more information on wiring the boiler and configuring the control system.

- 4) If there is more than one circulator zone for space heating, separate relays (or a relay panel) will need to be supplied for all space heating zones. The Boiler Loop Circulator is still controlled by the Boiler Pump output on the boiler and the indirect water heater can usually still be controlled by the DHW Pump output on the boiler.

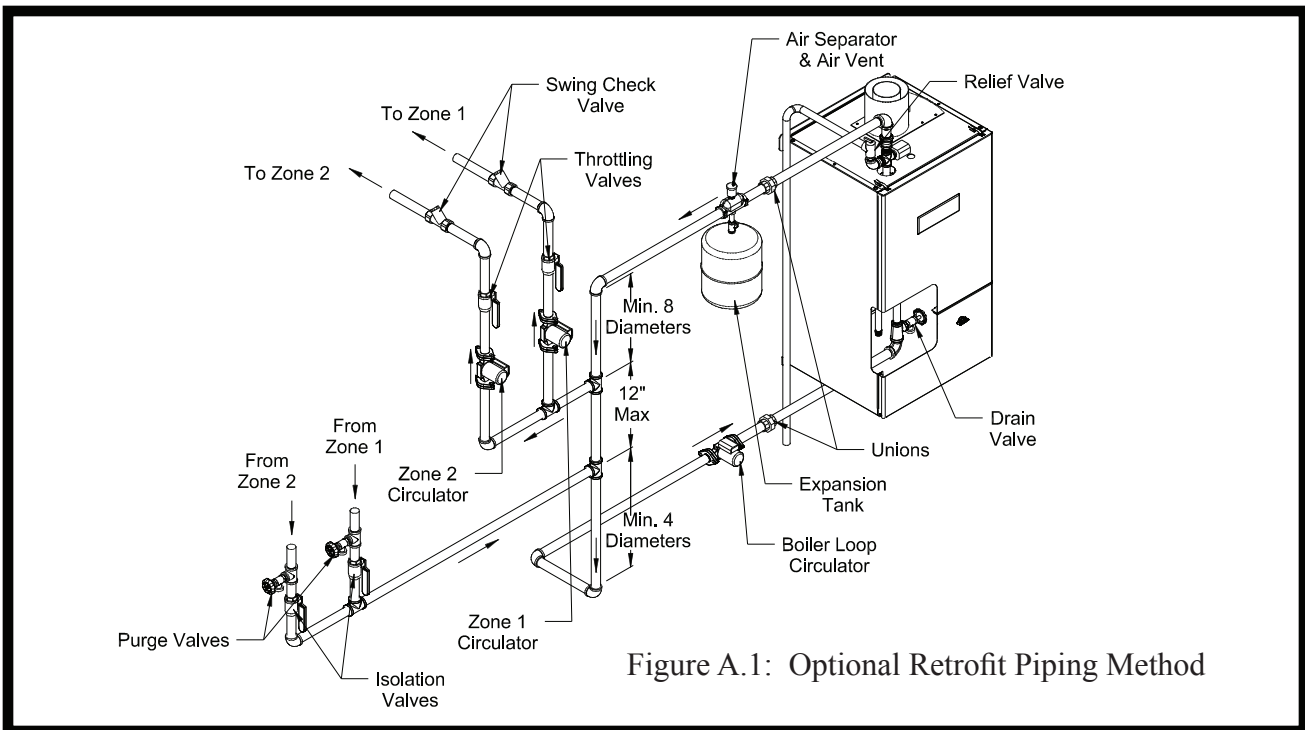

Appendix B: Special Requirements For Side-Wall Vented Appliances In The Commonwealth of Massachusetts

IMPORTANT

The Commonwealth of Massachusetts requires compliance with regulation 248 CMR 4.00 and 5.00 for installation of side-wall vented gas appliances as follows:

(a) For all side wall horizontally vented gas fueled equipment installed in every dwelling, building or structure used in whole or in part for residential purposes, including those owned or operated by the Commonwealth and where the side wall exhaust vent termination is less than seven (7) feet above finished grade in the area of the venting, including but not limited to decks and porches, the following requirements shall be satisfied:

1. **INSTALLATION OF CARBON MONOXIDE DETECTORS.** At the time of installation of the side wall horizontal vented gas fueled equipment, the installing plumber or gasfitter shall observe that a hard wired carbon monoxide detector with an alarm and battery back-up is installed on the floor level where the gas equipment is to be installed. In addition, the installing plumber or gasfitter shall observe that a battery operated or hard wired carbon monoxide detector with an alarm is installed on each additional level of the dwelling, building or structure served by the side wall horizontal vented gas fueled equipment. It shall be the responsibility of the property owner to secure the services of qualified licensed professionals for the installation of hard wired carbon monoxide detectors.

a. In the event that the side wall horizontally vented gas fueled equipment is installed in a crawl space or an attic, the hard wired carbon monoxide detector with alarm and battery back-up may be installed on the next adjacent floor level.

b. In the event that the requirements of this subdivision can not be met at the time of completion of installation, the owner shall have a period of thirty (30) days to comply with the above requirements; provided, however, that during said thirty (30) day period, a battery operated carbon monoxide detector with an alarm shall be installed.

2. **APPROVED CARBON MONOXIDE DETECTORS.** Each carbon monoxide detector as required in accordance with the above provisions shall comply with NFPA 720 and be ANSI/UL 2034 listed and IAS certified.

3. **SIGNAGE.** A metal or plastic identification plate shall be permanently mounted to the exterior of the building at a minimum height of eight (8) feet above grade directly in line with the exhaust vent terminal for the horizontally vented gas fueled heating appliance or equipment. The sign shall read, in print size no less than one-half (1/2) inch in size, "GAS VENT DIRECTLY BELOW. KEEP CLEAR OF ALL OBSTRUCTIONS".

4. **INSPECTION.** The state or local gas inspector of the side wall horizontally vented gas fueled equipment shall not approve the installation unless, upon inspection, the inspector observes carbon monoxide detectors and signage installed in accordance with the provisions of 248 CMR 5.08(2)(a)1 through 4.

(b) **EXEMPTIONS:** The following equipment is exempt from 248 CMR 5.08(2)(a)1 through 4:

1. The equipment listed in Chapter 10 entitled "Equipment Not Required To Be Vented" in the most current edition of NFPA 54 as adopted by the Board; and

2. Product Approved side wall horizontally vented gas fueled equipment installed in a room or structure separate from the dwelling, building or structure used in whole or in part for residential purposes.

(c) **MANUFACTURER REQUIREMENTS - GAS EQUIPMENT VENTING SYSTEM PROVIDED.** When the manufacturer of Product Approved side wall horizontally vented gas equipment provides a venting system design or venting system components with the equipment, the instructions provided by the manufacturer for installation of the equipment and the venting system shall include:

1. Detailed instructions for the installation of the venting system design or the venting system components; and
2. A complete parts list for the venting system design or venting system.

(d) MANUFACTURER REQUIREMENTS - GAS EQUIPMENT VENTING SYSTEM NOT PROVIDED. When the manufacturer of a Product Approved side wall horizontally vented gas fueled equipment does not provide the parts for venting the flue gases, but identifies “special venting systems”, the following requirements shall be satisfied by the manufacturer:

1. The referenced “special venting system” instructions shall be included with the appliance or equipment installation instructions; and
2. The “special venting systems” shall be Product Approved by the Board, and the instructions for that system shall include a parts list and detailed installation instructions.

(e) A copy of all installation instructions for all Product Approved side wall horizontally vented gas fueled equipment, all venting instructions, all parts lists for venting instructions, and/or all venting design instructions shall remain with the appliance or equipment at the completion of the installation.

THIS PAGE
INTENTIONALLY
LEFT BLANK



Manufacturer of Hydronic Heating Products
P.O. Box 14818 3633 I. Street
Philadelphia, PA 19134
www.crownboiler.com